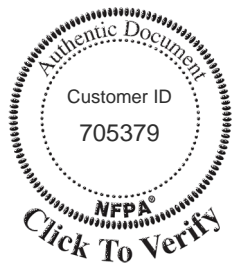


# NFPA<sup>®</sup> 99

## Health Care Facilities Code

2012 Edition



NFPA, 1 Batterymarch Park, Quincy, MA 02169-7471  
An International Codes and Standards Organization

**IMPORTANT NOTICES AND DISCLAIMERS CONCERNING NFPA® DOCUMENTS**  
**NOTICE AND DISCLAIMER OF LIABILITY CONCERNING THE USE OF NFPA DOCUMENTS**

NFPA® codes, standards, recommended practices, and guides (“NFPA Documents”), of which the document contained herein is one, are developed through a consensus standards development process approved by the American National Standards Institute. This process brings together volunteers representing varied viewpoints and interests to achieve consensus on fire and other safety issues. While the NFPA administers the process and establishes rules to promote fairness in the development of consensus, it does not independently test, evaluate, or verify the accuracy of any information or the soundness of any judgments contained in NFPA Documents.

The NFPA disclaims liability for any personal injury, property or other damages of any nature whatsoever, whether special, indirect, consequential or compensatory, directly or indirectly resulting from the publication, use of, or reliance on NFPA Documents. The NFPA also makes no guaranty or warranty as to the accuracy or completeness of any information published herein.

In issuing and making NFPA Documents available, the NFPA is not undertaking to render professional or other services for or on behalf of any person or entity. Nor is the NFPA undertaking to perform any duty owed by any person or entity to someone else. Anyone using this document should rely on his or her own independent judgment or, as appropriate, seek the advice of a competent professional in determining the exercise of reasonable care in any given circumstances.

The NFPA has no power, nor does it undertake, to police or enforce compliance with the contents of NFPA Documents. Nor does the NFPA list, certify, test, or inspect products, designs, or installations for compliance with this document. Any certification or other statement of compliance with the requirements of this document shall not be attributable to the NFPA and is solely the responsibility of the certifier or maker of the statement.

## IMPORTANT NOTICES AND DISCLAIMERS CONCERNING NFPA DOCUMENTS

### ADDITIONAL NOTICES AND DISCLAIMERS

#### Updating of NFPA Documents

Users of NFPA codes, standards, recommended practices, and guides (“NFPA Documents”) should be aware that these documents may be superseded at any time by the issuance of new editions or may be amended from time to time through the issuance of Tentative Interim Amendments. An official NFPA Document at any point in time consists of the current edition of the document together with any Tentative Interim Amendments and any Errata then in effect. In order to determine whether a given document is the current edition and whether it has been amended through the issuance of Tentative Interim Amendments or corrected through the issuance of Errata, consult appropriate NFPA publications such as the National Fire Codes® Subscription Service, visit the NFPA website at [www.nfpa.org](http://www.nfpa.org), or contact the NFPA at the address listed below.

#### Interpretations of NFPA Documents

A statement, written or oral, that is not processed in accordance with Section 6 of the Regulations Governing Committee Projects shall not be considered the official position of NFPA or any of its Committees and shall not be considered to be, nor be relied upon as, a Formal Interpretation.

#### Patents

The NFPA does not take any position with respect to the validity of any patent rights referenced in, related to, or asserted in connection with an NFPA Document. The users of NFPA Documents bear the sole responsibility for determining the validity of any such patent rights, as well as the risk of infringement of such rights, and the NFPA disclaims liability for the infringement of any patent resulting from the use of or reliance on NFPA Documents.

NFPA adheres to the policy of the American National Standards Institute (ANSI) regarding the inclusion of patents in American National Standards (“the ANSI Patent Policy”), and hereby gives the following notice pursuant to that policy:

**NOTICE:** The user’s attention is called to the possibility that compliance with an NFPA Document may require use of an invention covered by patent rights. NFPA takes no position as to the validity of any such patent rights or as to whether such patent rights constitute or include essential patent claims under the ANSI Patent Policy. If, in connection with the ANSI Patent Policy, a patent holder has filed a statement of willingness to grant licenses under these rights on reasonable and nondiscriminatory terms and conditions to applicants desiring to obtain such a license, copies of such filed statements can be obtained, on request, from NFPA. For further information, contact the NFPA at the address listed below.

#### Law and Regulations

Users of NFPA Documents should consult applicable federal, state, and local laws and regulations. NFPA does not, by the publication of its codes, standards, recommended practices, and guides, intend to urge action that is not in compliance with applicable laws, and these documents may not be construed as doing so.

#### Copyrights

NFPA Documents are copyrighted by the NFPA. They are made available for a wide variety of both public and private uses. These include both use, by reference, in laws and regulations, and use in private self-regulation, standardization, and the promotion of safe practices and methods. By making these documents available for use and adoption by public authorities and private users, the NFPA does not waive any rights in copyright to these documents.

Use of NFPA Documents for regulatory purposes should be accomplished through adoption by reference. The term “adoption by reference” means the citing of title, edition, and publishing information only. Any deletions, additions, and changes desired by the adopting authority should be noted separately in the adopting instrument. In order to assist NFPA in following the uses made of its documents, adopting authorities are requested to notify the NFPA (Attention: Secretary, Standards Council) in writing of such use. For technical assistance and questions concerning adoption of NFPA Documents, contact NFPA at the address below.

#### For Further Information

All questions or other communications relating to NFPA Documents and all requests for information on NFPA procedures governing its codes and standards development process, including information on the procedures for requesting Formal Interpretations, for proposing Tentative Interim Amendments, and for proposing revisions to NFPA documents during regular revision cycles, should be sent to NFPA headquarters, addressed to the attention of the Secretary, Standards Council, NFPA, 1 Batterymarch Park, P.O. Box 9101, Quincy, MA 02169-7471; email: [stds\\_admin@nfpa.org](mailto:stds_admin@nfpa.org)

For more information about NFPA, visit the NFPA website at [www.nfpa.org](http://www.nfpa.org).

Copyright © 2011 National Fire Protection Association®. All Rights Reserved.

## NFPA® 99

### Health Care Facilities Code

#### 2012 Edition

This edition of NFPA 99, *Health Care Facilities Code*, was prepared by the Technical Committees on Electrical Systems, Fundamentals, Health Care Emergency Management and Security, Hyperbaric and Hypobaric Facilities, Mechanical Systems, Medical Equipment, and Piping Systems, released by the Technical Correlating Committee on Health Care Facilities, and acted on by NFPA at its June Association Technical Meeting held June 12–15, 2011, in Boston, MA. It was issued by the Standards Council on August 11, 2011, with an effective date of August 31, 2011, and supersedes all previous editions.

Tentative interim amendments (TIAs) to Chapters 8 and 9 were issued on August 11, 2011. For further information on tentative interim amendments, see Section 5 of the NFPA Regulations Governing Committee Projects available at: <http://www.nfpa.org/assets/files/PDF/CodesStandards/TIAErrataFI/TIAREgs.pdf>

This edition of NFPA 99 was approved as an American National Standard on August 31, 2011.

#### Origin and Development of NFPA 99

The idea for this document grew as the number of documents under the original NFPA Committee on Hospitals grew. By the end of 1980, there existed 12 documents on a variety of subjects, 11 directly addressing fire-related problems in and about health care facilities. These documents covered health care emergency preparedness, inhalation anesthetics, respiratory therapy, laboratories in health-related institutions, hyperbaric facilities, hypobaric facilities, inhalation anesthetics in ambulatory care facilities, home use of respiratory therapy, medical-surgical vacuum systems in hospitals, essential electrical systems for health care facilities, safe use of electricity in patient care areas of health care facilities, and safe use of high-frequency electricity in health care facilities.

A history on the documents that covered these topics can be found in the “Origin and Development of NFPA 99” in the 1984 edition of NFPA 99.

What was then the Health Care Facilities Correlating Committee reviewed the matter beginning in late 1979 and concluded that combining all the documents under its jurisdiction would be beneficial to those who used those documents, for the following reasons:

- (1) The referenced documents were being revised independently of each other. Combining all the individual documents into one document would place all of them on the same revision cycle.
- (2) It would place in one unit many documents that referenced each other.
- (3) It would be an easier and more complete reference for the various users of the document (e.g., hospital engineers, medical personnel, designers and architects, and the various types of enforcing authorities).

To learn if this proposal was desired or desirable to users of the individual documents, the Committee issued a request for public comments in the spring of 1981, asking whether purchasers of the individual documents utilized more than one document in the course of their activities and whether combining these individual documents would be beneficial. Seventy-five percent of responses supported such a proposal, with 90 percent of health care facilities and organizations supportive of it. Based on this support, the Correlating Committee proceeded with plans to combine all the documents under its jurisdiction into one document.

In January, 1982, a compilation of the latest edition of each of the 12 individual documents under the jurisdiction of the Correlating Committee was published. It was designated NFPA 99, *Health Care Facilities Code*. The Correlating Committee also entered the document into the revision cycle reporting to the 1983 Fall Meeting for the purpose of formally adopting the document.

For the 1984 edition of NFPA 99, in addition to technical changes, administrative and organizational changes were made.

For the 1987 edition of NFPA 99, the third and final step in the process of combining the previous individual documents took place — that of integrating the content of these individual documents into a cohesive document. In addition, there were again technical changes made. The 1987 edition also saw the incorporation of NFPA 56F, *Standard on Nonflammable Medical Piped Gas Systems*, into NFPA 99.

For the 1990 edition of NFPA 99, some structural changes were made and some modifiers were added to make it easier to determine where requirements are applicable. Technical changes made included the following: correlation with NFPA 101<sup>®</sup>, *Life Safety Code*<sup>®</sup>; changes for compressed medical air systems on the use of gas-powered medical devices operating at a gauge pressure of 200 psi, and piped gas systems in general; changes in leakage current limits for patient care electrical appliances; clarification that patient care areas and wet locations are mutually exclusive; and further guidance on the effects of a disaster on staff.

For the 1993 edition of NFPA 99 there were further efforts to make the document more user-friendly (e.g., placing all “recommended” guidance either in notes or in the appendix). Significant technical changes included the following: adding requirements and recommendations to further prevent or minimize fires in operating rooms; making major changes to requirements in Chapter 4 for installing, testing, inspecting, verifying, and maintaining nonflammable medical piped gas systems; adding new sections on dental compressed air and dental vacuum requirements in Chapter 4; changing leakage current limits of patient care-related electrical appliances to correlate more closely with an international document on the subject; revising laboratory requirements to correlate more closely with NFPA 45, *Standard for Laboratories Using Chemicals*; changing essential electrical system requirements in ambulatory health care clinics and medical/dental offices; and extensively revising hyperbaric chamber requirements (Chapter 19).

For the 1996 edition of NFPA 99, further changes to make the document more user-friendly were made. These included restructuring Chapters 3 and 4 so that all requirements for a Type 1, 2, or 3 essential electrical system, or a Level 1, 2, 3, or 4 piped gas or vacuum system, were contained in one section.

Other technical changes included the following:

- (1) Moving requirements on flammable anesthetizing locations and the use of flammable inhalation anesthetics to a new Appendix 2
- (2) Upgrading the subject of emergency preparedness from guidance to a new chapter containing requirements
- (3) Adding a new chapter (Chapter 18) on home health care
- (4) Revising Section 1-1 to reflect the intent that NFPA 99 applies only to facilities treating human beings
- (5) In Chapter 3, revising load testing requirements for emergency generators to reference NFPA 110, *Standard for Emergency and Standby Power Systems*, and revising emergency lighting criteria for operating rooms
- (6) In Chapter 4, revising requirements for medical compressed air systems, dental compressed air systems, waste anesthetic gas disposal systems, and dental piped gas/vacuum systems; adding a new section on “headwall units” (“manufactured assemblies”); and clarifying and moving requirements for transfilling containers of liquid oxygen to Chapter 8
- (7) In Chapter 8, adding requirements for storage rooms containing cylinders and containers totaling less than 3000 ft<sup>3</sup>
- (8) In Chapters 12 to 17, revising criteria for gas and vacuum systems
- (9) In Chapter 19, in addition to many technical changes, adding criteria for mobile hyperbaric facilities

For the 1999 edition, significant technical and structural changes included the following:

- (1) Chapters 13, 14, and 15 (on ambulatory health care centers, clinics, and medical/dental offices, respectively) were replaced completely by new Chapter 13 covering health care facilities other than hospitals, nursing homes, and limited care facilities as defined in Chapter 2.
- (2) Requirements for Level 2 gas and vacuum systems were developed (Section 4.4 in Chapter 4).
- (3) Subsections 12.3.4, 16.3.4, and 7.3.4 were revised to correlate with the two significant changes in (1) and (2).
- (4) In Chapter 3, load testing requirements for emergency power supplies of the essential electrical system were changed through reference, and the testing interval (“monthly”) was reworded to be more responsive to needs of health care facilities.
- (5) Clarification of transfer switches and branches of the emergency system was made.
- (6) Clarification on the use of emergency power supplies other than for emergency power was made in 3.4.1.1.5.
- (7) Paragraph 4.3.1.2, Distribution Requirements for Level 1 Gas Systems, was completely revised and restructured.
- (8) Chapter 4 was made more user-friendly by reducing the number of internal cross-references between Sections 4.3 and 4.5.
- (9) The order of installation and testing requirements for piped gas and vacuum systems was revised.
- (10) Emphasis on emergency preparedness was made in Chapter 11 and its appendix material.
- (11) Chapter 19, “Hyperbaric Facilities,” was extensively revised in the areas of electrical wiring, air quality, ventilation lighting, equipment, communication, and safety management.
- (12) A new chapter (Chapter 20) on freestanding birthing centers was added.

The 2002 edition included format and technical revisions. The *Manual of Style for NFPA Technical Committee Documents*, April 2000 edition, was applied to this document, resulting in changes to its structure and format. Introductory material in Chapter 1 was formatted for consistency among all NFPA documents. Referenced publications that apply to the document were relocated from the last chapter to Chapter 2, resulting in the renumbering of chapters. Informational references remained in the last annex. Appendices were designated as annexes. Definitions in Chapter 3 were



reviewed for consistency with definitions in other NFPA documents, were systematically aligned, and were individually numbered. Paragraph structuring was revised with the intent of one mandatory requirement per section, subsection, or paragraph. Information that often accompanied many of the requirements was moved to Annex A, Explanatory Material. Exceptions were deleted or rephrased in mandatory text, unless the exception represented an allowance or required alternate procedure to a general rule when limited specified conditions exist. The reformatted appearance and structure provided continuity among NFPA documents, clarity of mandatory text, and greater ease in locating specific mandatory text.

The document scope and individual chapter scopes defining the intent of each chapter and document as a whole were located in Chapter 1.

The occupancy Chapters 13–21 stated what is required, while Chapters 4–12 prescribed how those requirements are achieved. Each chapter began with a section explaining applicability. Information concerning the nature of hazards was moved to Annex B. Annexes A and C retained explanatory information, and Annexes 1 and 2 became Annexes D and E. Informational references were in Annex F.

The changes in Chapter 4, Electrical Systems, addressed electrical wiring, transfer switches, inspection, and application.

Chapter 5 on Piping Systems was realigned so that Level 1 requirements were found in Section 5.1, and concurrently Level 2 in Section 5.2 and Level 3 in Section 5.3. Level 4 associated with laboratories was deleted, with requirements realigned in Chapter 11 on laboratories. Definitions were developed for vacuum systems and Levels 1, 2, and 3 gas systems in Chapter 3. Revisions were made to compressed gas cylinder identification and restraint; valve venting; ventilation of storage rooms; alarms; connection of the electrical supply for central supply systems with the essential electrical system; allowance of a three-way full port ball valve to isolate one branch or component; provisions for a monitored and audible low-content alarm on the surge gas while brazing; the allowance of medical air systems for application with human respiration; and deletion of 20-year-old appendix information.

Gas Delivery, Chapter 8, included a new section on the storage of compressed gas cylinders in patient care areas.

Chapter 11, Laboratories, clarified the structural protection of exits, and intent of portable fire extinguishers. Revisions were made concerning flammable and combustible liquids handling requirements.

An increased focus on the total process of maintaining services during a disaster, mitigating damage from a disaster, and recovery from a disaster was reflected in Chapter 12, Emergency Management. Annexed security program information was expanded.

Chapter 20, Hyperbaric Facilities, contained revised emergency depressurization requirements, safety director responsibilities, and emergency procedure performance.

The changes made to the 2005 edition were mainly for clarity and were editorial in nature. In Chapter 3, the definitions for medical gas, patient medical gas, and medical support gas were modified to differentiate between the different types of gases.

In Chapter 4, the requirements for switches and receptacles in anesthetizing locations were moved to Chapter 13, Hospital Requirements. The extracted material from NFPA 110, *Standard for Emergency and Standby Power Systems*, was updated.

In Chapter 5, the requirements for construction materials for filters, dryers, regulators, vacuum pumps, and after-coolers were changed to allow the manufacturers to choose the materials.

A centralized computer was allowed to be used in lieu of one of the master alarms. Cylinders were allowed to be fitted with a means to slow the initial opening pressure. The requirement to individually secure the cylinders was changed to no longer require the cylinders to be secured individually. Two new methods for making joints were added to the requirements. Stainless steel tubing was added as an approved material for vacuum systems. The requirement to braze a joint within 1 hour after cleaning was changed to 8 hours. Vacuum joints were required to be leak tested, and operational pressure testing was permitted to be conducted with the source gas.

Chapters 6, 7, 8, 9, 10, and 11 underwent minor changes for clarity or for editorial reasons.

Chapter 12 was revised to update the techniques used in emergency management in health care facilities.

In Chapters 13, 14, 15, 16, 17, 18, and 19 editorial corrections were made.

Chapter 20 was revised to include requirements for heating and ventilation changes in the chamber. Additional restrictions to the types of materials that are allowed in the chamber were added.

The 2012 edition went through a major overhaul. The premise of an occupancy-based document was modified to become a risk-based document. NFPA 99 was changed to a “code” instead of a “standard” to reflect how the document is used and adopted.

The administration of health care continues to change. NFPA 99 has changed to reflect how health care is delivered. The risk to the patient does not change for a given procedure. If the procedure is performed in a doctor’s office versus a hospital, the risk remains the same. Therefore, NFPA 99 eliminated the occupancy chapters and has gone to a risk-based approach. New Chapter 4 outlines the parameters for this approach. The Code now reflects the risk to the patient in defined categories of risk.

Chapter 5, Gas and Vacuum Systems, went through some editorial changes as well as adding new material on the testing and maintenance of gas and vacuum systems. In addition, the administrative details for care, maintenance, and handling of cylinders moved to chapters under the responsibility of the new Technical Committee on Medical Equipment.

There are several new chapters. There are new chapters on Information Technology and Communications Systems for Health Care Facilities; Plumbing; Heating, Ventilation, and Air Conditioning; Security Management; and Features of Fire Protection. Many of these systems were not addressed by NFPA 99. These are important systems and protection features in health care and needed to be addressed. The Technical Committees on Gas Delivery Equipment and the Technical Committee on Electrical Equipment were combined into a single Technical Committee on Medical Equipment. The hyperbaric chapter had relatively minor changes for clarity.



### Technical Correlating Committee on Health Care Facilities (HEA-AAC)

**Douglas S. Erickson**, *Chair*

American Society for Healthcare Engineering, VI [U]

**Constance Bobik**, B&E Fire Safety Equipment Inc.,  
FL [IM]

**Wayne L. Brannan**, Medical University of South Carolina,  
SC [U]

Rep. American Society of Safety Engineers

**Gordon D. Burrill**, Teegor Consulting Inc., Canada [U]

Rep. Canadian Healthcare Engineering Society

**David A. Dagenais**, Wentworth-Douglass Hospital,  
NH [U]

Rep. NFPA Health Care Section

**Marvin J. Fischer**, Monroe Township, NJ [SE]

**Robert M. Gagnon**, Gagnon Engineering, MD [SE]

**Thomas W. Jaeger**, Jaeger and Associates, LLC,  
VA [U]

Rep. American Health Care Association

**Michael S. Jensen**, U.S. Department of Health & Human  
Services, AZ [E]

**William E. Koffel**, Koffel Associates, Inc.,  
MD [SE]

**Mayer D. Zimmerman**, Randallstown, MD [SE]

#### Alternates

**H. Shane Ashby**, West Tennessee Healthcare, TN [U]

(Alt. to W. L. Brannan)

**Sharon S. Gilyeat**, Koffel Associates, Inc., MD [SE]

(Alt. to W. E. Koffel)

**W. Thomas Schipper**, Lakewood, CA [U]

(Alt. to D. S. Erickson)

**Richard P. Bielen**, NFPA Staff Liaison

*This list represents the membership at the time the Committee was balloted on the final text of this edition. Since that time, changes in the membership may have occurred. A key to classifications is found at the back of the document.*

NOTE: Membership on a committee shall not in and of itself constitute an endorsement of the Association or any document developed by the committee on which the member serves.

**Committee Scope:** This Committee shall have primary responsibility for documents that contain criteria for safeguarding patients and health care personnel in the delivery of health care services within health care facilities: a) from fire, explosion, electrical, and related hazards resulting either from the use of anesthetic agents, medical gas equipment, electrical apparatus, and high frequency electricity, or from internal or external incidents that disrupt normal patient care; b) from fire and explosion hazards associated with laboratory practices; c) in connection with the use of hyperbaric and hypobaric facilities for medical purposes; d) through performance, maintenance and testing criteria for electrical systems, both normal and essential; and e) through performance, maintenance and testing, and installation criteria: for vacuum systems for medical or surgical purpose, and for medical gas systems.

### Technical Committee on Electrical Systems (HEA-ELS)

**Walter N. Vernon, IV**, *Chair*

Mazzetti Nash Lipsey Burch, CA [SE]

**Dan Chisholm, Sr.**, MGI Systems, Inc., FL [IM]

**James H. Costley, Jr.**, Newcomb & Boyd, GA [SE]

Rep. NFPA Health Care Section

**Jason D'Antona**, Partners HealthCare System Inc.,  
MA [U]

**David A. Dagenais**, Wentworth-Douglass Hospital,  
NH [U]

**Herbert H. Daugherty**, Electric Generating Systems  
Association, NJ [M]

**James J. Dunn, Jr.**, University of Texas, TX [U]

**Tony Easty**, University Health Network, Canada [U]

**Jan Ehrenwerth**, Yale University, CT [C]

Rep. American Society of Anesthesiologists

**Chris M. Finen**, Eaton Electrical Corporation,  
TN [M]

**Don W. Jhonson**, Interior Electric, Inc., FL [IM]

Rep. National Electrical Contractors Association

**Burton R. Klein**, Burton Klein Associates,  
MA [SE]

**Stephen M. Lipster**, The Electrical Trades Center,  
OH [L]

Rep. International Brotherhood of Electrical Workers

**James E. Meade**, U.S. Army Corps of Engineers, MD [U]

**Joseph P. Murnane, Jr.**, Underwriters Laboratories Inc.,  
NY [RT]

**John Peterson**, Utility Service Corporation, AL [IM]

Rep. InterNational Electrical Testing Association

**Vincent M. Rea**, TLC Engineering for Architecture,  
FL [SE]

**Michael L. Savage, Sr.**, Middle Department Inspection  
Agency, Inc., MD [E]

**Ronald M. Smidt**, Carolinas HealthCare System, NC [U]

Rep. American Society for Healthcare Engineering

**Leonard W. White**, Stanford White Associates Consulting  
Engineers, Inc., NC [SE]

**James L. Wiseman**, Square D Company/Schneider  
Electric, TN [M]

**Robert Wolff**, IES Engineers-Dewberry, NC [SE]



**Alternates**

**David Bredhold**, Eaton Electrical Corporation,  
KY [M]  
(Alt. to C. M. Finen)

**Dan Chisholm, Jr.**, MGI Systems, Inc.,  
FL [IM]  
(Alt. to D. Chisholm, Sr.)

**Julian M. Goldman**, Massachusetts General Hospital,  
MA [C]  
(Alt. to J. Ehrenwerth)

**Nancy W. Gunderson**, Square D Company/Schneider  
Electric, NC [M]  
(Alt. to J. L. Wiseman)

**Donald D. King**, Kaiser Permanente, CA [U]  
(Alt. to R. M. Smidt)

**Hugh O. Nash, Jr.**, Mazzetti Nash Lipsey Burch, TN [SE]  
(Alt. to W. N. Vernon, IV)

**Herbert V. Whittall**, Electrical Generating Systems  
Association, FL [M]  
(Alt. to H. H. Daugherty)

**Richard P. Bielen**, NFPA Staff Liaison

*This list represents the membership at the time the Committee was balloted on the final text of this edition. Since that time, changes in the membership may have occurred. A key to classifications is found at the back of the document.*

NOTE: Membership on a committee shall not in and of itself constitute an endorsement of the Association or any document developed by the committee on which the member serves.

**Committee Scope:** This Committee shall have primary responsibility for documents or portions of documents covering the minimum requirements for performance, testing, maintenance, operations, and failure management of electrical systems, low voltage systems, wireless technologies, infomatics, and telemedicine to safeguard patients, staff, and visitors within health care facilities.

**Technical Committee on Fundamentals (HEA-FUN)**

**Michael A. Crowley**, *Chair*  
The RJA Group, Inc., TX [SE]

**Gordon D. Burrill**, Teegor Consulting Inc., Canada [U]  
Rep. Canadian Healthcare Engineering Society

**Richard E. Cutts**, NORAD/NORTHCOM (USAF),  
GA [U]

**August F. DiManno, Jr.**, Program Risk Management, Inc.,  
NY [I]

**Michael S. Jensen**, U.S. Department of Health & Human  
Services, AZ [E]

Rep. U.S. Dept. of Health & Human Services/IHS

**David P. Klein**, U.S. Department of Veterans Affairs,  
DC [U]

**James K. Lathrop**, Koffel Associates, Inc., CT [SE]

**Barry Lefler**, Chubb Group of Insurance Companies,  
NC [I]

**Stephen M. Lipster**, The Electrical Trades Center,  
OH [L]

Rep. International Brotherhood of Electrical Workers  
**Jack McNamara**, Bosch Security Systems, NY [M]

Rep. National Electrical Manufacturers Association  
**Thomas G. McNamara**, North Shore LJJ Health  
System-Southside Hospital, NY [U]

**James S. Peterkin**, Heery International-HLM Design,  
PA [SE]

**W. Thomas Schipper**, Lakewood, CA [U]

Rep. American Society for Healthcare Engineering  
**Frank L. Van Overmeiren**, FP&C Consultants, Inc.,  
IN [SE]

**Robert F. Willey, III**, North Carolina Dept. of Health  
& Human Services, NC [E]

**Alternates**

**Beth A. Alexander**, FP&C Consultants, Inc.,  
IN [SE]

(Alt. to F. L. Van Overmeiren)

**Chad E. Beebe**, American Society for Healthcare  
Engineering, WA [U]

(Alt. to W. T. Schipper)

**Sharon S. Gilyeat**, Koffel Associates, Inc., MD [SE]  
(Alt. to J. K. Lathrop)

**Peter Leszczak**, U.S. Department of Veterans Affairs,  
CT [U]

(Alt. to D. P. Klein)

**Terrence Pintar**, The RJA Group, Inc., IL [SE]  
(Alt. to M. A. Crowley)

**Richard P. Bielen**, NFPA Staff Liaison

*This list represents the membership at the time the Committee was balloted on the final text of this edition. Since that time, changes in the membership may have occurred. A key to classifications is found at the back of the document.*

NOTE: Membership on a committee shall not in and of itself constitute an endorsement of the Association or any document developed by the committee on which the member serves.

**Committee Scope:** This Committee shall have primary responsibility for documents or portions of documents on the scope, application, and intended use of documents under the Health Care Facilities Project, including reference standards, performance, the protection of special hazards, criteria for levels of health care services based on risk, as well as definitions not assigned to other committees in the Health Care Facilities Project.

**Technical Committee on Health Care Emergency  
Management and Security (HEA-HES)**

**George F. Stevens, Chair**

U.S. Department of Health & Human Services

**Robert M. Becker**, Incident Management Solutions, Inc.,  
NY [SE]

**Pete Brewster**, U.S. Department of Veterans Affairs,  
WV [U]

**David A. Dagenais**, Wentworth-Douglass Hospital,  
NH [U]

**Steve Ennis**, Virginia Hospital & Healthcare Association,  
VA [U]

**Jon M. Evenson**, The RJA Group, Inc., IL [SE]

**Scott R. Fernhaber**, Johnson Controls, Inc.,  
WI [M]

**Sharon S. Gilyeat**, Koffel Associates, Inc.,  
MD [SE]

**Susan B. McLaughlin**, MSL Healthcare Consulting, Inc.,  
IL [U]

Rep. American Society for Healthcare Engineering  
**William C. McPeck**, State of Maine Employee Health  
& Safety, ME [E]

**Russell Phillips**, Russell Phillips & Associates, LLC,  
NY [SE]

**Tom Mayer Scheidel**, Centers for Medicare and Medicaid  
Services, TX [E]

**James P. Simpson**, National Joint Apprenticeship & Training  
Committee, MN [L]

Rep. International Brotherhood of Electrical Workers

**Michael D. Widdekind**, Zurich Services Corporation,  
MD [I]

**Alternates**

**Chad E. Beebe**, American Society for Healthcare  
Engineering, WA [U]

(Alt. to S. B. McLaughlin)

**Jennifer L. Frecker**, Koffel Associates, Inc., MD [SE]

(Alt. to S. S. Gilyeat)

**Nicholas E. Gabriele**, Russell Phillips & Associates, LLC,  
CT [SE]

(Alt. to R. Phillips)

**Zachary Goldfarb**, Incident Management Solutions, Inc.,  
NY [SE]

(Alt. to R. M. Becker)

**Richard A. Mahnke**, The RJA Group, Inc.,

IL [SE]

(Alt. to J. M. Evenson)

**Richard P. Bielen**, NFPA Staff Liaison

*This list represents the membership at the time the Committee was balloted on the final text of this edition. Since that time, changes in the membership may have occurred. A key to classifications is found at the back of the document.*

NOTE: Membership on a committee shall not in and of itself constitute an endorsement of the Association or any document developed by the committee on which the member serves.

**Committee Scope:** This Committee shall have primary responsibility for documents or portions of documents covering the framework for emergency management and security of health care facilities proportionate to the risk of the patient and health care staff. This Committee shall have primary responsibility for the elements of planning over a continuum from minor incidences to catastrophic events, including: management controls, mitigation practices, incident response, continuity of services, recovery, stored capacity, staff training, and program evaluation.

## Technical Committee on Hyperbaric and Hypobaric Facilities (HEA-HYP)

**Robert B. Sheffield**, *Chair*  
International ATMO, Inc., TX [U]

**Michael W. Allen**, Life Support Technologies Group Inc., PA [U]  
**Peter Atkinson**, Townsville Hospital, Australia [C]  
Rep. Hyperbaric Technicians & Nurses Association Inc.  
**Richard C. Barry**, Diversified Clinical Services, FL [SE]  
**James Bell**, Intermountain Health Care, UT [U]  
**W. Robert Bryant**, Perry Baromedical Corporation, TX [M]  
**Mario Caruso**, Comprehensive Healthcare Solutions, Inc., FL [SE]  
**Keith Ferrari**, Praxair, NC [M]  
**Angela M. Fuqua**, Chubb Group Insurance Companies, TX [I]  
**William C. Gearhart**, University of Maryland Medical Systems, MD [U]

**W. T. Gurnée**, OxyHeal Health Group, CA [M]  
**Barry E. Newton**, Wendell Hull & Associates, Inc., NM [SE]  
**Stephen D. Reimers**, Reimers Systems, Inc., VA [M]  
**Rachael Sheets**, The Linde Group, NJ [IM]  
**John M. Skinner**, Medical Equipment Technology, Inc., GA [IM]  
**Deepak Talati**, Sechrist Industries, Inc., CA [M]  
**Harry G. Vincent**, Baromedical Nurses Association, LA [C]  
**Wilbur T. Workman**, Undersea & Hyperbaric Medical Society, TX [U]

### Alternates

**Kevin I. Posey**, International ATMO, Inc., TX [U]  
(Alt. to R. B. Sheffield)

**Richard P. Bielen**, NFPA Staff Liaison

*This list represents the membership at the time the Committee was balloted on the final text of this edition. Since that time, changes in the membership may have occurred. A key to classifications is found at the back of the document.*

NOTE: Membership on a committee shall not in and of itself constitute an endorsement of the Association or any document developed by the committee on which the member serves.

**Committee Scope:** This Committee shall have primary responsibility for documents or portions of documents covering the construction, installation, testing, performance, and maintenance of hyperbaric and hypobaric facilities for safeguarding staff and occupants of chambers.

## Technical Committee on Mechanical Systems (HEA-MEC)

**Roger W. Lautz**, *Chair*  
Affiliated Engineers, Inc., WI [SE]

**Kimberly A. Barker**, Siemens Building Technologies, Inc., IL [M]  
**Christopher Bernecker**, H. T. Lyons, Inc., PA [IM]  
**Gordon D. Burrill**, Teegor Consulting Inc., Canada [U]  
Rep. Canadian Healthcare Engineering Society  
**Robert J. Dubiel**, Luther Midelfort Mayo Health, WI [U]  
**Keith Ferrari**, Praxair, NC [M]  
**Ronald E. Galloway**, Moses Cone Health System, NC [U]

**Phil Gioia**, Mazzetti & Associates Inc., OR [SE]  
**Charles Seyffer**, Camfil Farr, NY [M]  
**Michael P. Sheerin**, TLC Engineering for Architecture, FL [SE]  
**Michael Soper**, Phoenix Controls Corporation, MA [M]  
**Allan David Volz**, OSF HealthCare System, IL [U]

**Richard P. Bielen**, NFPA Staff Liaison

*This list represents the membership at the time the Committee was balloted on the final text of this edition. Since that time, changes in the membership may have occurred. A key to classifications is found at the back of the document.*

NOTE: Membership on a committee shall not in and of itself constitute an endorsement of the Association or any document developed by the committee on which the member serves.

**Committee Scope:** This committee shall have primary responsibility for documents or portions of documents covering the performance, operations, testing, maintenance, and failure management criteria for air quality, temperature, humidity, critical space pressure relationships, water and waste water, and their associated systems.



## Technical Committee on Medical Equipment (HEA-MED)

**Alan Lipschultz**, *Chair*

Christiana Care Health Services, DE [M]  
Rep. Association for the Advancement of Medical Instrumentation

**Michael E. Brousseau**, Intertek Testing Services, MA [RT]  
**Susan E. Dorsch**, Orange Park, FL [SE]  
**Robert J. Dubiel**, Luther Midelfort Mayo Health, WI [U]  
**Keith Ferrari**, Praxair, NC [M]  
Rep. Compressed Gas Association  
**William C. Fettes**, Airgas, Inc., KS [IM]  
**Gerald R. Goodman**, Texas Woman's University, TX [SE]  
**Harvey Kostinsky**, ECRI Institute, PA [RT]

**Joseph P. Murnane, Jr.**, Underwriters Laboratories Inc., NY [RT]  
**Ezra R. Safdie**, U.S. Department of Veterans Affairs, CA [U]  
**Lawrence S. Sandler**, Bonita Springs, FL [SE]  
**W. Thomas Schipper**, Lakewood, CA [U]  
Rep. American Society for Healthcare Engineering  
**Robert M. Sutter**, B&R Compliance Associates, PA [SE]

### Alternates

**Gary L. Bean**, Air Products & Chemicals, Inc., GA [M]  
(Alt. to K. Ferrari)  
**Barry E. Brown**, Airgas, Inc., GA [IM]  
(Alt. to W. C. Fettes)

**John T. Collins**, American Society for Healthcare Engineering, IL [U]  
(Alt. to W. T. Schipper)  
**Mike W. Schmidt**, Strategic Device Compliance Services, OH [M]  
(Alt. to A. Lipschultz)

### Nonvoting

**Saul Aronow**, Auburndale, MA [SE]  
(Member Emeritus)

**Richard P. Bielen**, NFPA Staff Liaison

*This list represents the membership at the time the Committee was balloted on the final text of this edition. Since that time, changes in the membership may have occurred. A key to classifications is found at the back of the document.*

NOTE: Membership on a committee shall not in and of itself constitute an endorsement of the Association or any document developed by the committee on which the member serves.

**Committee Scope:** This committee shall have primary responsibility for documents or portions of documents covering the maintenance, performance, and testing of electrical medical equipment and portable patient-related gas equipment for the purpose of safeguarding patients and health care personnel within patient care areas of health care facilities from the hazards of fire, explosion, electricity, nonionizing radiation, heat, and electrical interference.

## Technical Committee on Piping Systems (HEA-PIP)

**David B. Mohile**, *Chair*

Medical Engineering Services, Inc., VA [SE]

**Mark W. Allen**, Beacon Medaes, SC [M]  
**Grant A. Anderson**, Bard, Rao & Athanas Consulting Engineers, LLC, MA [SE]  
**David L. Brittain**, ProVac, OH [M]  
**Jan Ehrenwerth**, Yale University, CT [C]  
Rep. American Society of Anesthesiologists  
**Keith Ferrari**, Praxair, NC [M]  
Rep. Compressed Gas Association  
**William C. Fettes**, Airgas, Inc., KS [IM]  
**Michael Frankel**, Utility Systems Consultants, FL [SE]  
Rep. American Society of Plumbing Engineers  
**Ed Golla**, TRI/Air Testing, TX [RT]  
**James L. Lucas**, Tri-Tech Medical Inc., OH [M]  
**Edward J. Lyczko**, The Cleveland Clinic, OH [U]  
**Jeffery F. McBride**, Red Lion Medgas Consultants, Inc., DE [SE]  
**Donald R. McIlroy**, Providence Health System, OR [U]  
**Jerry L. McManus**, National ITC Corporation, LA [L]  
Rep. Piping Industry Progress & Education Trust Fund

**Thomas J. Mraulak**, Plumbing Industry Training Center, MI [L]  
Rep. American Society of Sanitary Engineering  
**Olen L. Pruitt**, University of Alabama at Birmingham, AL [U]  
Rep. American Society for Healthcare Engineering  
**E. Daniel Shoemaker**, Midmark Corporation, AZ [M]  
**Ronald M. Smidt**, Carolinas HealthCare System, NC [U]  
Rep. NFPA Health Care Section  
**Russell C. Thomason**, U.S. Army Corps of Engineers, VA [U]  
**J. Richard Wagner**, J. Richard Wagner, PE, LLC, MD [IM]  
Rep. Mechanical Contractors Association of America, Inc.  
**Jonathan C. Willard**, Certified Medical Gas Services, NH [SE]  
**Wayne T. Wozniak**, American Dental Association, IL [U]

**Alternates**

**Gary L. Bean**, Air Products & Chemicals, Inc.,  
GA [M]

(Alt. to K. Ferrari)

**Chad E. Beebe**, American Society for Healthcare  
Engineering, WA [U]

(Alt. to O. L. Pruitt)

**Barry E. Brown**, Airgas, Inc.,  
GA [IM]

(Alt. to W. C. Fettes)

**David D. Eastman**, Metro Detroit Plumbing Industry  
Training Center, MI [L]

(Alt. to T. J. Mraulak)

**P. L. Fan**, Arlington Heights, IL [U]  
(Alt. to W. T. Wozniak)

**Michael T. Massey**, National ITC Corporation, CA [L]  
(Alt. to J. L. McManus)

**Christopher Swayze**, The Sherman Engineering  
Company, PA [M]  
(Alt. to M. W. Allen)

**Richard P. Bielen**, NFPA Staff Liaison

*This list represents the membership at the time the Committee was balloted on the final text of this edition. Since that time, changes in the membership may have occurred. A key to classifications is found at the back of the document.*

NOTE: Membership on a committee shall not in and of itself constitute an endorsement of the Association or any document developed by the committee on which the member serves.

**Committee Scope:** This Committee shall have primary responsibility for documents or portions of documents covering the performance, maintenance, installation, and testing of medical and dental related gas piping systems and medical and dental related vacuum piping systems.

Contents

<b>Chapter 1 Administration</b> .....	<b>99- 13</b>	<b>Chapter 8 Plumbing</b> .....	<b>99- 91</b>
1.1 Scope .....	99- 13	8.1 Applicability .....	99- 91
1.2 Purpose .....	99- 13	8.2 System Category Criteria .....	99- 91
1.3 Application .....	99- 13	8.3 General Requirements .....	99- 92
1.4 Equivalency .....	99- 14	<b>Chapter 9 Heating, Ventilation, and Air</b>	
1.5 Units .....	99- 14	<b>Conditioning (HVAC)</b> .....	99- 92
1.6 Code Adoption Requirements .....	99- 14	9.1 Applicability .....	99- 92
<b>Chapter 2 Referenced Publications</b> .....	<b>99- 14</b>	9.2 System Category Criteria .....	99- 92
2.1 General .....	99- 14	9.3 General .....	99- 92
2.2 NFPA Publications .....	99- 14	<b>Chapter 10 Electrical Equipment</b> .....	<b>99- 94</b>
2.3 Other Publications .....	99- 15	10.1 Applicability .....	99- 94
2.4 References for Extracts in Mandatory		10.2 Performance Criteria and Testing for	
Sections .....	99- 16	Patient Care–Related Electrical	
<b>Chapter 3 Definitions</b> .....	<b>99- 17</b>	Appliances and Equipment .....	99- 94
3.1 General .....	99- 17	10.3 Testing Requirements — Fixed and	
3.2 NFPA Official Definitions .....	99- 17	Portable .....	99- 95
3.3 General Definitions .....	99- 17	10.4 Nonpatient Electrical Appliances and	
3.4 BICSI Definitions .....	99- 25	Equipment .....	99- 96
<b>Chapter 4 Fundamentals</b> .....	<b>99- 25</b>	10.5 Administration .....	99- 96
4.1 Building System Categories .....	99- 25	<b>Chapter 11 Gas Equipment</b> .....	<b>99-100</b>
4.2 Risk Assessment .....	99- 25	11.1 Applicability .....	99-100
4.3 Application .....	99- 25	11.2 Cylinder and Container Source .....	99-100
<b>Chapter 5 Gas and Vacuum Systems</b> .....	<b>99- 25</b>	11.3 Cylinder and Container Storage	
5.1 Category 1 Piped Gas and Vacuum		Requirements .....	99-100
Systems .....	99- 25	11.4 Performance Criteria and Testing .....	99-101
5.2 Category 2 Piped Gas and Vacuum		11.5 Administration .....	99-101
Systems .....	99- 56	11.6 Operation and Management of	
5.3 Category 3 Piped Gas and Vacuum		Cylinders .....	99-103
Systems .....	99- 57	11.7 Liquid Oxygen Equipment .....	99-104
<b>Chapter 6 Electrical Systems</b> .....	<b>99- 73</b>	<b>Chapter 12 Emergency Management</b> .....	<b>99-105</b>
6.1 Applicability .....	99- 73	12.1 Scope .....	99-105
6.2 Nature of Hazards .....	99- 73	12.2 Responsibilities .....	99-105
6.3 Electrical System .....	99- 73	12.3 Matrix Categories .....	99-105
6.4 Essential Electrical System		12.4 General .....	99-105
Requirements — Type 1 .....	99- 78	12.5 Category 1 and Category 2	
6.5 Essential Electrical System		Requirements .....	99-105
Requirements — Type 2 .....	99- 85	<b>Chapter 13 Security Management</b> .....	<b>99-109</b>
6.6 Essential Electrical System		13.1 Scope .....	99-109
Requirements — Type 3 .....	99- 86	13.2 Security Vulnerability Assessment	
<b>Chapter 7 Information Technology and</b>		(SVA) .....	99-109
<b>Communications Systems for</b>		13.3 Responsible Person .....	99-109
<b>Health Care Facilities</b> .....	<b>99- 87</b>	13.4 Security-Sensitive Areas .....	99-109
7.1 Applicability .....	99- 87	13.5 Access and Egress Security Measures .....	99-110
7.2 Reserved .....	99- 87	13.6 Media Control .....	99-110
7.3 Category 1 Systems .....	99- 87	13.7 Crowd Control .....	99-110
7.4 Category 2 Systems .....	99- 90	13.8 Security Equipment .....	99-110
7.5 Category 3 Systems .....	99- 91	13.9 Employment Practices .....	99-110
		13.10 Security Operations .....	99-110
		13.11 Program Evaluation .....	99-111

<b>Chapter 14 Hyperbaric Facilities</b> .....	<b>99-111</b>	15.8 Automatic Sprinklers and Other Extinguishing Equipment .....	<b>99-124</b>
14.1 Scope .....	<b>99-111</b>	15.9 Manual Extinguishing Equipment .....	<b>99-124</b>
14.2 Construction and Equipment .....	<b>99-111</b>	15.10 Compact Storage .....	<b>99-125</b>
14.3 Administration and Maintenance .....	<b>99-119</b>	15.11 Compact Mobile Storage .....	<b>99-125</b>
<b>Chapter 15 Features of Fire Protection</b> .....	<b>99-122</b>	15.12 Maintenance and Testing .....	<b>99-125</b>
15.1 Applicability .....	<b>99-122</b>	15.13 Fire Loss Prevention in Operating Rooms .....	<b>99-125</b>
15.2 Construction and Compartmentation ....	<b>99-122</b>	<b>Annex A Explanatory Material</b> .....	<b>99-125</b>
15.3 Special Hazard Protection for Flammable Liquids and Gases .....	<b>99-122</b>	<b>Annex B Additional Explanatory Notes</b> .....	<b>99-175</b>
15.4 Laboratories .....	<b>99-122</b>	<b>Annex C Sample Ordinance Adopting NFPA 99</b> ...	<b>99-193</b>
15.5 Utilities .....	<b>99-122</b>	<b>Annex D Informational References</b> .....	<b>99-193</b>
15.6 Rubbish Chutes, Incinerators, and Laundry Chutes .....	<b>99-123</b>	<b>Index</b> .....	<b>99-197</b>
15.7 Fire Detection, Alarm, and Communications Systems .....	<b>99-123</b>		

NFPA 99

Health Care Facilities Code

2012 Edition

**IMPORTANT NOTE:** This NFPA document is made available for use subject to important notices and legal disclaimers. These notices and disclaimers appear in all publications containing this document and may be found under the heading "Important Notices and Disclaimers Concerning NFPA Documents." They can also be obtained on request from NFPA or viewed at [www.nfpa.org/disclaimers](http://www.nfpa.org/disclaimers).

Changes to the content of this code have not been marked by vertical rules and deletion bullets due to the fact that the entire document has undergone restructuring.

A reference in brackets [ ] following a section or paragraph indicates material that has been extracted from another NFPA document. As an aid to the user, the complete title and edition of the source documents for extracts in mandatory sections of the document are given in Chapter 2 and those for extracts in informational sections are given in Annex D. Extracted text may be edited for consistency and style and may include the revision of internal paragraph references and other references as appropriate. Requests for interpretations or revisions of extracted text shall be sent to the technical committee responsible for the source document.

Information on referenced publications can be found in Chapter 2 and Annex D.

Chapter 1 Administration

1.1 Scope.

1.1.1 The scope of this code is to establish minimum criteria as follows in 1.1.2 through 1.1.13.

1.1.2 **Fundamentals.** Chapter 4 establishes criteria for levels of health care services or systems based on risk to the patients, staff, or visitors in health care facilities.

1.1.3 Gas and Vacuum Systems.

1.1.3.1 Chapter 5 covers the performance, maintenance, installation, and testing of the following:

- (1) Nonflammable medical gas systems with operating pressures below a gauge pressure of 2068 kPa (300 psi)
- (2) Vacuum systems in health care facilities
- (3) Waste anesthetic gas disposal (WAGD) systems, also referred to as scavenging
- (4) Manufactured assemblies that are intended for connection to the medical gas, vacuum, or WAGD systems (also referred to as scavenging)

1.1.3.2 Requirements for portable compressed gas systems are covered in Chapter 11.

1.1.4 Electrical Systems.

1.1.4.1 Chapter 6 covers the performance, maintenance, and testing of electrical systems (both normal and essential) in health care facilities.

1.1.4.2 The following areas are not addressed in this code, but are addressed in other NFPA documents:

- (1) Specific requirements for wiring and installation of equipment are covered in *NFPA 70, National Electrical Code*.

- (2) Requirements for illumination and identification of means of egress in health care facilities are covered in *NFPA 101, Life Safety Code*.
- (3) Requirements for installation, testing, and maintenance of fire protection signaling systems are covered in *NFPA 72, National Fire Alarm and Signaling Code*.
- (4) Requirements for installation of fire pumps are covered in *NFPA 20, Standard for the Installation of Stationary Pumps for Fire Protection*, except that the alternate source of power are permitted to be the essential electrical system.
- (5) Requirements for installation of stationary engines and gas turbines are covered in *NFPA 37, Standard for the Installation and Use of Stationary Combustion Engines and Gas Turbines*.

**1.1.5 Information Technology and Communications Systems.** Chapter 7 covers the performance, maintenance, and testing of information technology and communications systems in health care facilities.

**1.1.6 Plumbing.** Chapter 8 covers the performance, maintenance, and testing of plumbing systems in health care facilities.

**1.1.7 HVAC Systems.** Chapter 9 covers the performance, maintenance, and testing of heating, cooling, and ventilating in health care facilities.

**1.1.8 Electrical Equipment.** Chapter 10 covers the performance, maintenance, and testing of electrical equipment in health care facilities.

**1.1.9 Gas Equipment.** Chapter 11 covers the performance, maintenance, and testing of gas equipment in health care facilities.

**1.1.10\* Emergency Management.** Chapter 12 establishes criteria for emergency management in the development of a program for effective disaster preparedness, response, mitigation, and recovery in health care facilities.

**1.1.11 Security Management.** Chapter 13 covers the performance, maintenance, and testing of security equipment and systems in health care facilities.

**1.1.12\* Hyperbaric Facilities.** Chapter 14 covers the recognition of, and protection against, hazards of an electrical, explosive, or implosive nature, as well as fire hazards associated with hyperbaric chambers and associated facilities that are used, or intended to be used, for medical applications and experimental procedures at gauge pressures from 0 kPa to 690 kPa (0 psi to 100 psi).

**1.1.13 Features of Fire Protection.** Chapter 15 covers the performance, maintenance, and testing of fire protection equipment in health care facilities.

**1.2 Purpose.** The purpose of this code is to provide minimum requirements for the installation, inspection, testing, maintenance, performance, and safe practices for facilities, material, equipment, and appliances, including other hazards associated with the primary hazards.

1.3 Application.

1.3.1 This code shall apply to all health care facilities other than home care.

1.3.1.1 This document is intended for use by those persons involved in the design, construction, inspection, and operation of health care facilities and in the design, manufacture, and testing of appliances and equipment used in patient care rooms of health care facilities.



**1.3.2** Construction and equipment requirements shall be applied only to new construction and new equipment, except as modified in individual chapters.

**1.3.2.1** Only the altered, renovated, or modernized portion of an existing system or individual component shall be required to meet the installation and equipment requirements stated in this code.

**1.3.2.2** If the alteration, renovation, or modernization adversely impacts the existing performance requirements of a system or component, additional upgrading shall be required.

**1.3.2.3** An existing system that is not in strict compliance with the provisions of this code shall be permitted to be continued in use, unless the authority having jurisdiction has determined that such use constitutes a distinct hazard to life.

### **1.3.3 Policies.**

**1.3.3.1** The health care organization shall ensure that policies are established and maintained that permit the attending physician to satisfy the emergency needs of any patient that supersede the requirements of this code.

**1.3.3.2** Each such special use shall be clearly documented and reviewed to attempt to have future similar needs met within the requirements of this code.

### **1.3.4 Patient Care Rooms.**

**1.3.4.1** The governing body of the facility or its designee shall establish the following areas in accordance with the type of patient care anticipated and with the following definitions of the classification (*see definition of patient care room in Chapter 3*):

- (1) Critical care rooms
- (2) General care rooms
- (3) Basic care rooms
- (4) Support rooms

**1.3.4.2 Anesthesia.** It shall be the responsibility of the governing body of the health care organization to designate anesthetizing locations.

**1.3.4.3 Wet Procedure Locations.** It shall be the responsibility of the governing body of the health care organization to designate wet procedure locations.

### **1.4 Equivalency.**

**1.4.1** Nothing in this code is intended to prevent the use of systems, methods, or devices of equivalent or superior quality, strength, fire resistance, effectiveness, durability, and safety to those prescribed by this code. Technical documentation shall be submitted to the authority having jurisdiction to demonstrate equivalency. The system, method, or device shall be approved for the intended purpose by the authority having jurisdiction.

**1.4.2** Alternative systems, methods, or devices approved as equivalent by the authority having jurisdiction shall be recognized as being in compliance with this code.

**1.4.3** The authority having jurisdiction shall be permitted to grant exceptions to this code.

**1.5\* Units.** Primary units will be trade units, and secondary units will be the conversion.

### **1.6 Code Adoption Requirements.**

**1.6.1** The effective date of application of any provision of this document is not determined by the National Fire Protection

Association. All questions related to applicability shall be directed to the authority having jurisdiction.

**1.6.2 Enforcement.** This code shall be administered and enforced by the authority having jurisdiction. (*See Annex C for a sample wording for enabling legislation.*)

## **Chapter 2 Referenced Publications**

**2.1\* General.** The documents or portions thereof listed in this chapter are referenced within this code and shall be considered part of the requirements of this document.

**2.2 NFPA Publications.** National Fire Protection Association, 1 Batterymarch Park, Quincy, MA 02169-7471.

NFPA 10, *Standard for Portable Fire Extinguishers*, 2010 edition.  
NFPA 13, *Standard for the Installation of Sprinkler Systems*, 2010 edition.

NFPA 14, *Standard for the Installation of Standpipe and Hose Systems*, 2010 edition.

NFPA 20, *Standard for the Installation of Stationary Pumps for Fire Protection*, 2010 edition.

NFPA 25, *Standard for the Inspection, Testing, and Maintenance of Water-Based Fire Protection Systems*, 2011 edition.

NFPA 30, *Flammable and Combustible Liquids Code*, 2012 edition.

NFPA 31, *Standard for the Installation of Oil-Burning Equipment*, 2011 edition.

NFPA 37, *Standard for the Installation and Use of Stationary Combustion Engines and Gas Turbines*, 2010 edition.

NFPA 45, *Standard on Fire Protection for Laboratories Using Chemicals*, 2011 edition.

NFPA 54, *National Fuel Gas Code*, 2012 edition.

NFPA 55, *Compressed Gases and Cryogenic Fluids Code*, 2010 edition.

NFPA 58, *Liquefied Petroleum Gas Code*, 2011 edition.

NFPA 70<sup>®</sup>, *National Electrical Code*<sup>®</sup>, 2011 edition.

NFPA 72<sup>®</sup>, *National Fire Alarm and Signaling Code*, 2010 edition.

NFPA 82, *Standard on Incinerators and Waste and Linen Handling Systems and Equipment*, 2009 edition.

NFPA 90A, *Standard for the Installation of Air-Conditioning and Ventilating Systems*, 2012 edition.

NFPA 91, *Standard for Exhaust Systems for Air Conveying of Vapors, Gases, Mists, and Noncombustible Particulate Solids*, 2010 edition.

NFPA 92, *Standard for Smoke Control Systems*, 2012 edition.

NFPA 99, *Health Care Facilities Code*, 2012 edition.

NFPA 99B, *Standard for Hypobaric Facilities*, 2010 edition.

NFPA 101<sup>®</sup>, *Life Safety Code*<sup>®</sup>, 2012 edition.

NFPA 101A, *Guide on Alternative Approaches to Life Safety*, 2010 edition.

NFPA 110, *Standard for Emergency and Standby Power Systems*, 2010 edition.

NFPA 111, *Standard on Stored Electrical Energy Emergency and Standby Power Systems*, 2010 edition.

NFPA 211, *Standard for Chimneys, Fireplaces, Vents, and Solid Fuel-Burning Appliances*, 2010 edition.

NFPA 259, *Standard Test Method for Potential Heat of Building Materials*, 2008 edition.

NFPA 286, *Standard Methods of Fire Tests for Evaluating Contribution of Wall and Ceiling Interior Finish to Room Fire Growth*, 2011 edition.

NFPA 704, *Standard System for the Identification of the Hazards of Materials for Emergency Response*, 2012 edition.

NFPA 1600<sup>®</sup>, *Standard on Disaster/Emergency Management and Business Continuity Programs*, 2010 edition.

NFPA 5000<sup>®</sup>, *Building Construction and Safety Code*<sup>®</sup>, 2012 edition.

### 2.3 Other Publications.

**2.3.1 ANSI Publications.** American National Standards Institute, Inc., 22 West 43rd Street, 4th Floor, New York, NY 10036.

ANSI C84.1, *Electric Power Systems and Equipment — Voltage Ratings*, 1995.

ANSI Z136.3, *Safe Use of Optical Fiber Communication Systems Utilizing Laser Diode and LED Sources*, 2011.

ANSI/NEMA WD 6, *Wiring Devices — Dimensional Requirements*, 2002.

ANSI/UL 723, *Standard for Test for Surface Burning Characteristics of Building Materials*, 2010.

ANSI/AAMI ES 60601-1, *Medical Electrical Equipment*, 2005.

**2.3.2 AHSRAE Publications.** American Society of Heating, Refrigerating and Air Conditioning Engineers, Inc., 1791 Tullie Circle, NE, Atlanta, GA 30329-2305

ASHRAE 170, *Ventilation of Health Care Facilities*, 2008.

ASHRAE 90.1, *Energy Standard for Buildings Except Low-Rise Residential Buildings*, 2010.

ASHRAE Guideline 0, *The Commissioning Process*, 2005.

ASHRAE Guideline 1.1, *HVAC&R Technical Requirements for The Commissioning Process*, 2007.

**2.3.3 ASME Publications.** American Society of Mechanical Engineers, Three Park Avenue, New York, NY 10016-5990.

ASME A.17.1, *Safety Code for Elevators and Escalators*, 2010.

ASME A.17.3, *Safety Code for Existing Elevators and Escalators*, 2008.

ASME B1.20.1, *Pipe Threads, General Purpose, Inch*, 2001.

ASME B16.22, *Wrought Copper and Copper Alloy Solder-Joint Pressure Fittings*, 2001.

ASME B16.26, *Cast Copper Alloy Fittings for Flared Copper Tubes*, 2006.

ANSI/ASME B16.50, *Wrought Copper and Copper Alloy Braze-Joint Pressure Fittings*, 2001.

ASME B31.3, *Pressure Process Piping*, 2002.

ASME B40.100, *Pressure Gauges and Gauge Attachments*, 1998.

ASME *Boiler and Pressure Vessel Code*, Sections VIII and IX, 2001.

ANSI/ASME PVHO-1, *Safety Standard for Pressure Vessels for Human Occupancy*, 1990

**2.3.4 ASSE Publications.** American Society of Sanitary Engineering, 901 Canterbury Road, Suite A, Westlake, OH 44145-1480.

ASSE 6010, *Professional Qualification Standard for Medical Gas Systems Installers*, 2001.

ASSE 6030, *Professional Qualification Standard for Medical Gas Systems Verifiers*, 2001.

ASSE 6040, *Professional Qualification Standard for Medical Gas Maintenance Personnel*, 2001.

**2.3.5 ASTM Publications.** ASTM International, 100 Barr Harbor Drive, P.O. Box C700, West Conshohocken, PA 19428-2959.

ASTM B 32, *Standard Specification for Solder Metal*, 1996.

ASTM B 88, *Standard Specification for Seamless Copper Water Tube*, 2002.

ASTM B 280, *Standard Specification for Seamless Copper Tubing for Air Conditioning and Refrigeration Field Service*, 2002.

ASTM B 819, *Standard Specification for Seamless Copper Tube for Medical Gas Systems*, 2000.

ASTM B 828, *Standard Practice for Making Capillary Joints by Soldering of Copper and Copper Alloy Tube and Fittings*, 2002.

ASTM D 5, *Standard Test Method for Penetration of Bituminous Materials*, 1997.

ASTM D 1785, *Standard Specification for Poly (Vinyl Chloride) (PVC) Plastic Pipe, Schedules 40, 80, and 120*, 2006.

ASTM D 2466, *Standard Specification for Poly (Vinyl Chloride) (PVC) Plastic Pipe Fittings, Schedule 40*, 2006.

ASTM D 2467, *Standard Specification for Poly (Vinyl Chloride) (PVC) Plastic Pipe Fittings, Schedule 80*, 2006.

ASTM D 2672, *Standard Specification for Joints for IPS PVC Pipe Using Solvent Cement*, 2010.

ASTM D 2846, *Standard Specification for Chlorinated Poly (Vinyl Chloride) (CPVC) Plastic Hot- and Cold-Water Distribution Systems*, 2009b.

ASTM D 2863, *Standard Test Method for Measuring the Minimum Oxygen Concentration to Support Candle-Like Combustion of Plastics (Oxygen Index) (ANSI D2863)*, 1997.

ASTM E 84, *Standard Test Method for Surface Burning Characteristics of Building Materials*, 2010.

ASTM E 136, *Standard Test Method for Behavior of Materials in a Vertical Tube Furnace at 750°C*, 1998.

ASTM F 438, *Standard Specification for Socket-Type Chlorinated Poly (Vinyl Chlorinated) (CPVC) Plastic Pipe Fittings, Schedule 40*, 2009.

ASTM F 439, *Standard Specification for Chlorinated Poly (Vinyl Chlorinated) (CPVC) Plastic Pipe Fittings, Schedule 80*, 2009.

ASTM F 441, *Standard Specification for Chlorinated Poly (Vinyl Chloride) (CPVC) Plastic Pipe, Schedules 40 and 80*, 2009.

ASTM F 493, *Solvent Cements for CPVC Pipe and Fittings*, 2004.

**2.3.6 AWS Publications.** American Welding Society, 550 NW LeJeune Road, Miami, FL 33126.

ANSI/AWS A5.8, *Specification for Filler Metals for Brazing and Braze Welding*, 1992.

AWS B2.2, *Standard for Brazing Procedure and Performance Qualification*, 1991.

**2.3.7 BICSI Publications.** BICSI, 8610 Hidden River Parkway, Tampa, FL 33637-1000.

*Telecommunications Distribution Methods Manual*, 11th edition, 2006.

*The BICSI Information Transport Systems (ITS) Dictionary*, 3rd edition.

**2.3.8 CDA Publications.** Copper Development Association Inc., 260 Madison Avenue, New York, NY 10016.

*Copper Tube Handbook*, 2010.

**2.3.9 CGA Publications.** Compressed Gas Association, 4221 Walney Road, 5th Floor, Chantilly, VA 20151-2923.

CGA C-4, *Method of Marking Portable Compressed Gas Containers to Identify the Material Contained*, 1954.

CGA C-7, *Guide to the Preparation of Precautionary Labeling and Marking of Compressed Gas Containers*, 2004.

CGA G-4, *Oxygen*, 2008.

CGA G-4.1, *Cleaning Equipment for Oxygen Service*, 2009.

CGA G-6.1, *Standard for Insulated Carbon Dioxide Systems at Consumer Sites*, 2005.

CGA G-6.5, *Standard for Small, Stationary, Insulated Carbon Dioxide Supply Systems*, 2007.

CGA G-8.1, *Standard for Nitrous Oxide Systems at Consumer Sites*, 2007.

CGA M-1, *Guide for Medical Gas Installations at Consumer Sites*, 2007.

CGA O2-DIR, *Directory of Cleaning Agents for Oxygen Service*, Edition 4.

CGA P-2.5, *Transfilling of High Pressure Gaseous Oxygen to be Used for Respiration*, 2007.

CGA P-2.6, *Transfilling of Liquid Oxygen to be Used for Respiration*, 2008.

CGA P-2.7, *Guide for the Safe Storage, Handling, and Use of Portable Liquid Oxygen Systems in Healthcare Facilities*, 2008.

CGA P-18, *Standard for Bulk Inert Gas Systems at Consumer Sites*, 2006.

CGA V-1, *Compressed Gas Association Standard for Compressed Gas Cylinder Valve Outlet and Inlet Connections (ANSI B57.1)*, 2005.

CGA V-5, *Diameter-Index Safety System (Noninterchangeable Low Pressure Connections for Medical Gas Applications)*, 2008.

CGA V-6, *Standard Cryogenic Liquid Transfer Connection*, 2008.

**2.3.10 CSA Publications.** Canadian Standards Association, 5060 Spectrum Way, Mississauga, ON, L4W 5N6, Canada.

CSA C22.2 No. 0.3, *Test Methods for Electrical Wires and Cables*, 2009.

**2.3.11 IEC Publications.** International Electrotechnical Commission, 3, rue de Varembe, P.O. Box 131, CH-1211 Geneva 20, Switzerland.

IEC 60601-1-2, *Medical Electrical Equipment — Part 1-2: General Requirements for Safety — Collateral Standard: Electromagnetic Compatibility — Requirements and Tests*, 2004.

**2.3.12 ISA Publications.** Instrumentation, Systems, and Automation Society (ISA), 67 Alexander Drive, Research Triangle Park, NC 27709.

ANSI/ISA S-7.0.01, *Quality Standard for Instrument Air*, 1996.

RP 12.6, *Installation of Intrinsically Safe Systems in Hazardous Locations*, 1995.

**2.3.13 MSS Publications.** Manufacturer's Standardization Society of the Valve and Fittings Industry, Inc., 127 Park Street NE, Vienna, VA 22180.

SP-58, *Pipe Hangers and Supports — Materials, Design, Manufacture, Selection, Application and Installation*, 2009

**2.3.14 TC Publications.** Transport Canada, 330 Sparks Street, Ottawa, ON, K1A/ON5, Canada.

*Transportation of Dangerous Goods Regulations*.

**2.3.15 TIA Publications.** Telecommunications Industry Association, 2500 Wilson Boulevard, Suite 300, Arlington, VA 22201.

TIA/EIA 568-B, *Commercial Building Telecommunications Cabling Standard*, 2003.

TIA/EIA 606-A, *Administration Standard for Commercial Telecommunications Infrastructure*, 2002.

**2.3.16 UL Publications.** Underwriters Laboratories Inc., 333 Pfingsten Road, Northbrook, IL 60062-2096.

UL 263, *Standard for Fire Test of Building Construction and Materials*, 2003.

UL 723, *Standard for Test for Surface Burning Characteristics of Building Materials*, 2008.

UL 1685, *Standard for Vertical-Tray Fire-Propagation and Smoke-Release Test for Electrical and Optical-Fiber Cables*, 2007.

**2.3.17 U.S. Government Publications.** Document Automation and Production Service (DAPS), Building 4D, 700 Robbins Avenue, Philadelphia, PA 19111-5094, www.dodssp.daps.mil.

21 USC 9, United States Food, Drug, and Cosmetic Act.

U.S. Government Commercial Standard 223-59, *Casters, Wheels, and Glides for Hospital Equipment*.

**2.3.18 Other Publications.**

*Merriam-Webster's Collegiate Dictionary*, 11th edition, Merriam-Webster, Inc., Springfield, MA, 2003.

CSA C22.2 No. 0.3-M, *Test Methods for Electrical Wires and Cables*, 2009.

**2.4 References for Extracts in Mandatory Sections.**

NFPA 13, *Standard for the Installation of Sprinkler Systems*, 2010 edition.

NFPA 30, *Flammable and Combustible Liquids Code*, 2012 edition.

NFPA 45, *Standard on Fire Protection for Laboratories Using Chemicals*, 2011 edition.

NFPA 55, *Compressed Gases and Cryogenic Fluids Code*, 2010 edition.

NFPA 70<sup>®</sup>, *National Electrical Code*<sup>®</sup>, 2011 edition.

NFPA 90A, *Standard for the Installation of Air-Conditioning and Ventilating Systems*, 2012 edition.

NFPA 99B, *Standard for Hypobaric Facilities*, 2010 edition.

NFPA 101<sup>®</sup>, *Life Safety Code*<sup>®</sup>, 2012 edition.

NFPA 110, *Standard for Emergency and Standby Power Systems*, 2010 edition.

NFPA 1670, *Standard on Operations and Training for Technical Search and Rescue Incidents*, 2009 edition.

NFPA 5000<sup>®</sup>, *Building Construction and Safety Code*<sup>®</sup>, 2012 edition.



## Chapter 3 Definitions

**3.1 General.** The definitions contained in this chapter shall apply to the terms used in this code. Where terms are not defined in this chapter or within another chapter, they shall be defined using their ordinarily accepted meanings within the context in which they are used. *Merriam-Webster's Collegiate Dictionary*, 11th edition, shall be the source for the ordinarily accepted meaning.

### 3.2 NFPA Official Definitions.

**3.2.1\* Approved.** Acceptable to the authority having jurisdiction.

**3.2.2\* Authority Having Jurisdiction (AHJ).** An organization, office, or individual responsible for enforcing the requirements of a code or standard, or for approving equipment, materials, an installation, or a procedure.

**3.2.3\* Code.** A standard that is an extensive compilation of provisions covering broad subject matter or that is suitable for adoption into law independently of other codes and standards.

**3.2.4 Guide.** A document that is advisory or informative in nature and that contains only nonmandatory provisions. A guide may contain mandatory statements such as when a guide can be used, but the document as a whole is not suitable for adoption into law.

**3.2.5 Labeled.** Equipment or materials to which has been attached a label, symbol, or other identifying mark of an organization that is acceptable to the authority having jurisdiction and concerned with product evaluation, that maintains periodic inspection of production of labeled equipment or materials, and by whose labeling the manufacturer indicates compliance with appropriate standards or performance in a specified manner.

**3.2.6\* Listed.** Equipment, materials, or services included in a list published by an organization that is acceptable to the authority having jurisdiction and concerned with evaluation of products or services, that maintains periodic inspection of production of listed equipment or materials or periodic evaluation of services, and whose listing states that either the equipment, material, or service meets appropriate designated standards or has been tested and found suitable for a specified purpose.

**3.2.7 Shall.** Indicates a mandatory requirement.

**3.2.8 Should.** Indicates a recommendation or that which is advised but not required.

**3.2.9 Standard.** A document, the main text of which contains only mandatory provisions using the word "shall" to indicate requirements and which is in a form generally suitable for mandatory reference by another standard or code or for adoption into law. Nonmandatory provisions shall be located in an appendix or annex, footnote, or fine-print note and are not to be considered a part of the requirements of a standard.

### 3.3 General Definitions.

**3.3.1 ACFM.** Actual cubic feet per minute. (PIP)

**3.3.2 Adiabatic Heating.** The heating of a gas caused by its compression. (HYP)

**3.3.3 Aerosol.** An intimate mixture of a liquid or a solid in a gas; the liquid or solid, called the dispersed phase, is uniformly distributed in a finely divided state throughout the gas, which is the continuous phase or dispersing medium. (MED)

### 3.3.4 Alarm System.

**3.3.4.1 Area Alarm System.** A warning system within an area of use that provides continuous visible and audible surveillance of Category 1 and Category 2 medical gas and vacuum systems. (PIP)

**3.3.4.2 Category 3 Alarm System.** A warning system within an area of use that provides continuous visible and audible surveillance of Category 3 medical gas systems. (PIP)

**3.3.4.3 Local Alarm System.** A warning system that provides continuous visible and audible surveillance of medical gas and vacuum system source equipment at the equipment site. (PIP)

**3.3.4.4 Master Alarm System.** A warning system that monitors the operation and condition of the source of supply, the reserve source (if any), and the pressure in the main lines of each medical gas and vacuum piping system. (PIP)

**3.3.5 Alternate Power Source.** One or more generator sets, or battery systems where permitted, intended to provide power during the interruption of the normal electrical service; or the public utility electrical service intended to provide power during interruption of service normally provided by the generating facilities on the premises. (ELS)

**3.3.6 Ambulatory Health Care Center.** A building or portion thereof used to provide services or treatment simultaneously to four or more patients that (1) provides, on an outpatient basis, treatment for patients that renders the patients incapable of taking action for self-preservation under emergency conditions without the assistance of others; or (2) provides, on an outpatient basis, anesthesia that renders the patients incapable of taking action for self-preservation under emergency conditions without the assistance of others. (FUN)

**3.3.7 Ampacity.** The current, in amperes, that a conductor can carry continuously under the conditions of use without exceeding its temperature rating. (ELS)

**3.3.8 Anesthetic.** As used in this code, applies to any inhalational agent used to produce sedation, analgesia, or general anesthesia. (MED)

**3.3.9\* Anesthetizing Location.** Any area of a facility that has been designated to be used for the administration of general anesthesia. (MED)

**3.3.10 Anoxia.** A state of markedly inadequate oxygenation of the tissues and blood, of more marked degree than hypoxia. (HYP)

**3.3.11 Appliance.** Utilization equipment, generally other than industrial, normally built in standardized sizes or types, that is installed or connected as a unit to perform one or more functions. (MED)

**3.3.12\* Applicator.** A means of applying high-frequency energy to a patient other than by an electrically conductive connection. (MED)

**3.3.13 Area of Administration.** Any point within a room within 4.3 m (15 ft) of oxygen equipment or an enclosure containing or intended to contain an oxygen-enriched atmosphere. (MED)

**3.3.14\* Atmosphere.** The pressure exerted by, and gaseous composition of, an environment. (HYP)

**3.3.14.1 Ambient Atmosphere.** The pressure and composition of the environment surrounding a chamber. (HYP)

**3.3.14.2 Atmosphere Absolute (ATA).** The pressure of the earth's atmosphere, 760.0 mmHg, 101.325 kPa, or 14.7 psia. Two ATA = two atmospheres. (See also 3.3.14, *Atmosphere*.) (HYP)

**3.3.14.3\* Atmosphere of Increased Burning Rate.** Any atmosphere containing a percentage of oxygen or oxygen and nitrous oxide greater than the quotient of 23.45 divided by the square root of the total pressure in atmospheres. (HYP)

**3.3.14.4 Chamber Atmosphere.** The environment inside a chamber. (HYP)

**3.3.15 Automatic.** Providing a function without the necessity of human intervention. (ELS)

**3.3.16 Bathrooms.** An area including a basin with one or more of the following: a toilet, a tub, or a shower. (FUN)

**3.3.17 Battery-Powered Lighting Units.** Individual unit equipment for backup illumination consisting of a rechargeable battery, battery-charging means, provisions for one or more lamps mounted on the equipment, or with terminals for remote lamps, or both, and relaying device arranged to energize the lamps automatically upon failure of the supply to the unit equipment. [70, 2011] (ELS)

**3.3.18 Bends.** Decompression sickness; caisson worker's disease. (HYP)

**3.3.19 Branch Circuit.** The circuit conductors between the final overcurrent device protecting the circuit and the outlet(s). [70, 2011] (ELS)

**3.3.20 Branch Line.** See 3.3.144, Piping.

**3.3.21 Bulk System.** An assembly of equipment, such as storage containers, pressure regulators, pressure relief devices, vaporizers, manifolds, and interconnecting piping, that terminates at the source valve of oxygen or 1452 kg (3200 lb) of nitrous oxide, including unconnected reserves on the site. (PIP)

**3.3.21.1 Bulk Inert Gas System.** An assembly of equipment consisting of, but not limited to, storage containers, pressure regulators, pressure relief devices, vaporizers, manifolds, and piping, with a storage capacity of more than 20,000 ft<sup>3</sup> (566 m<sup>3</sup>) of inert gas including unconnected reserves on hand at the site. The bulk system terminates at the point where the gas supply, at service pressure, first enters the supply line. The containers are either stationary or movable, and the source gas is stored as a compressed gas or cryogenic fluid. (PIP)

**3.3.21.2 Bulk Nitrous Oxide System.** An assembly of equipment as described in the definition of *bulk oxygen system* that has a storage capacity of more than 1452 kg (3200 lb) [approximately 793 m<sup>3</sup> (28,000 ft<sup>3</sup>) (at normal temperature and pressure)] of nitrous oxide. (PIP)

**3.3.21.3\* Bulk Oxygen System.** An assembly of equipment such as oxygen storage containers, pressure regulators, pressure relief devices, vaporizers, manifolds, and interconnecting piping that has a storage capacity of more than 566 m<sup>3</sup> (20,000 ft<sup>3</sup>) of oxygen (at normal temperature and pressure), including unconnected reserves on hand at the site. (PIP)

**3.3.22 Category 3 Drive Gas System.** An assembly of component parts including, but not limited to, the source, pressure and operating controls, filters and purification equipment, valves, alarm warning systems, alarm wiring, gauges, and a network of piping and suitable outlets that produces and distrib-

utes compressed air from cylinders, compressed air from compressors, or nitrogen from cylinders less than 1100 kPa gauge (less than 160 psi gauge) to power devices (hand pieces, syringes, cleaning devices, delivery system chairs, and so forth) as a power source. The system includes the compressor intakes and ends with the service outlet where the user connects their clinical equipment. (PIP)

**3.3.23 Category 3 Vacuum System.** A Category 3 vacuum distribution system that can be either a wet system designed to remove liquids, air-gas, or solids from the treated area; or a dry system designed to trap liquid and solids before the service inlet and to accommodate air-gas only through the service inlet. (PIP)

**3.3.24 Cold Room.** A refrigerated area large enough for personnel to enter.

**3.3.25 Combustible.** Capable of undergoing combustion. (MED)

**3.3.26\* Combustible Liquid.** Any liquid that was a closed-cup flash point at or above 37.8°C (100°F). Combustible liquids are classified as follows: (a) Class II liquid. Any liquid that has a flash point at or above 37.8°C (100°F) and below 60°C (140°F); (b) Class IIIA liquid. Any liquid that has a flash point at or above 60°C (140°F) and below 93°C (200°F); (c) Class IIIB liquid. Any liquid that has a flash point at or above 93°C (200°F).

**3.3.27\* Combustion.** A chemical process of oxidation that occurs at a rate fast enough to produce heat and usually light in the form of either a glow or flame. [5000, 2012] (HYP)

**3.3.28 Compact Storage.** Storage on solid shelves not exceeding 0.9 m (36 in.) in total depth, arranged as part of a compact storage module, with no more than 0.76 m (30 in.) between shelves vertically and with no internal vertical flue spaces other than those between individual shelving sections. [13, 2010] (FUN)

**3.3.29 Container.** A low-pressure, vacuum-insulated vessel containing gases in liquid form. (MED)

**3.3.29.1 Liquid Oxygen Ambulatory Container.** A container used for liquid oxygen not exceeding 1.5 L (0.396 gal) specifically designed for use as a medical device as defined by 21 USC Chapter 9, the United States Food, Drug and Cosmetic Act, that is intended for portable therapeutic use and to be filled from its companion base unit, which is a liquid oxygen home care container. (MED)

**3.3.29.2 Liquid Oxygen Base Reservoir Container.** A container used for liquid oxygen not exceeding 60 L (15.8 gal) specifically designed for use as a medical device as defined by 21 USC Chapter 9, the United States Food, Drug and Cosmetic Act, that is intended to deliver gaseous oxygen for therapeutic use, transfilling, or both. (MED)

**3.3.29.3 Liquid Oxygen Home Care Container.** A container used for liquid oxygen not exceeding 60 L (15.8 gal) specifically designed for use as a medical device as defined by 21 USC Chapter 9, the United States Food, Drug and Cosmetic Act, that is intended to deliver gaseous oxygen for therapeutic use in a home environment. (MED)

**3.3.29.4 Liquid Oxygen Portable Container.** A container used for liquid oxygen not exceeding 1.5 L (0.396 gal) specifically designed for use as a medical device as defined by 21 USC Chapter 9, the United States Food, Drug and Cosmetic Act, that is intended for portable therapeutic use and to be filled from its companion base unit, which is a liquid oxygen base reservoir container. (MED)

**3.3.30 Critical Branch.** system of feeders and branch circuits supplying power for task illumination, fixed equipment, select receptacles, and select power circuits serving areas and functions related to patient care that are automatically connected to alternate power sources by one or more transfer switches during interruption of the normal power source. (ELS)

**3.3.31 Critical Care Area.** See 3.3.138, Patient Care Room.

**3.3.32 Critical Equipment.** That equipment essential to the safety of the occupants of the facility. (HYP)

**3.3.33 Cylinder.** A supply tank containing high-pressure gases or gas mixtures at pressures that can be in excess of 13.8 kPa gauge (2000 psi gauge). (MED)

**3.3.34 Decompression Sickness.** A syndrome due to evolved gas in the tissues resulting from a reduction in ambient pressure. (HYP)

**3.3.35\* Defend in Place.** The operational response to an emergency in a building, in which the initial action does not involve evacuation of the building occupants. (FUN)

**3.3.36 Demand Check.** A paired set of fittings that permit gas flow when correctly mated but interrupt flow when separated. (PIP)

**3.3.37 Detonation.** An exothermic reaction wherein the reaction propagates through the unreacted material at a rate exceeding the velocity of sound, hence the explosive noise. (MED)

**3.3.38\* Direct Electrical Pathway to the Heart.** An externalized conductive pathway, insulated except at its ends, one end of which is in direct contact with heart muscle while the other is outside the body and is accessible for inadvertent or intentional contact with grounded objects or energized, ground-referenced sources. (MED)

**3.3.39\* Disaster.** Within the context of this code, any unusual occurrence or unforeseen situation that seriously overtaxes or threatens to seriously overtax the routine capabilities of a health care facility. (HES)

**3.3.40 D.I.S.S. Connector.** A system of noninterchangeable medical gas and vacuum connectors complying with CGA V-5, *Diameter-Index Safety System (Noninterchangeable Low Pressure Connections for Medical Gas Applications)*. (PIP)

**3.3.41\* Double-Insulated Appliances.** Appliances where the primary means of protection against electrical shock is not grounding. The primary means is by the use of combinations of insulation and separation spacings in accordance with an approved standard. (MED)

**3.3.42 Electrical Life Support Equipment.** Electrically powered equipment whose continuous operation is necessary to maintain a patient's life. (ELS)

**3.3.43 Electrode.** An electrically conductive connection to a patient. (MED)

**3.3.43.1 Active Electrode.** An electrode intended to generate a surgical or physiological effect at its point of application to the patient. (MED)

**3.3.43.2 Bipolar Electrode.** An electrode consisting of adjacent contacts (e.g., the two legs of a forceps) such that the current passes between the pair of contacts generating the intended effect. (MED)

**3.3.43.3\* Dispersive Electrode.** An electrode intended to complete the electrical path between patient and appliance and at which no surgical effect is intended. (MED)

**3.3.44 Emergency Management.** The act of developing procedures and plans to create effective preparedness, mitigation, response, and recovery during a disaster affecting a health care facility. (HES)

**3.3.45 Emergency Oxygen Supply Connection.** An assembly of equipment that permits a gas supplier to make a temporary connection to supply oxygen to a building that has had its normal source of oxygen disconnected. (PIP)

**3.3.46 Equipment Branch.** A system of feeders and branch circuits arranged for delayed, automatic, or manual connection to the alternate power source and that serves primarily 3-phase power equipment. (ELS)

**3.3.47 Equipment Grounding Bus.** A grounding terminal bus in the feeder circuit of the branch circuit distribution panel that serves a particular area. (MED)

**3.3.48\* Essential Electrical System.** A system comprised of alternate sources of power and all connected distribution systems and ancillary equipment, designed to ensure continuity of electrical power to designated areas and functions of a health care facility during disruption of normal power sources, and also to minimize disruption within the internal wiring system. (ELS)

**3.3.49 Evacuation — Waste Gas.** See 3.3.183, Waste Anesthetic Gas Disposal.

**3.3.50 Exposed Conductive Surfaces.** Those surfaces that are capable of carrying electric current and that are unprotected, uninsulated, unenclosed, or unguarded, permitting personal contact. (ELE)

**3.3.51\* Failure.** An incident that increases the hazard to personnel or patients or that affects the safe functioning of electric appliances or devices. (MED)

**3.3.52 Fault Current.** A current in an accidental connection between an energized and a grounded or other conductive element resulting from a failure of insulation, spacing, or containment of conductors. (ELS)

**3.3.53 Feeder.** All circuit conductors between the service equipment, the source of a separately derived system, or other power supply source and the final branch-circuit overcurrent device. (ELS)

**3.3.54\* Flammable.** A combustible that is capable of easily being ignited and rapidly consumed by fire.

**3.3.55 Flammable Gas.** Any substance that exists in the gaseous state at normal atmospheric temperature and pressure and is capable of being ignited and burned when mixed with proper proportion of air, oxygen, or other oxidizers. (HYP)

**3.3.56 Flammable Liquid.** A liquid that has a closed-cup flash point that is below 37.8°C (100°F) and a maximum vapor pressure of 2068 mmHg (40 psi absolute) at 37.8°C (100°F).

**3.3.57\* Flash Point.** The minimum temperature at which a liquid or a solid emits vapor sufficient to form an ignitable mixture with air near the surface of the liquid or the solid. (FUN)

**3.3.58 Flow-Control Valve.** A valve, usually a needle valve, that precisely controls flow of gas. (MED)

**3.3.59 Flowmeter.** A device for measuring volumetric flow rates of gases and liquids. (MED)

**3.3.59.1 Pressure Compensated Flowmeter.** A flowmeter indicating accurate flow of gas whether the gas is discharged into ambient pressure or into a system at nonambient pressure. (MED)

**3.3.60\* Frequency.** The number of oscillations, per unit time, of a particular current or voltage waveform. The unit of frequency is the hertz. (MED)

**3.3.61\* Fume Hood.** An enclosure designed to draw air inward by means of mechanical ventilation.

**3.3.62 Gas-Powered System.** A Level 3 gas distribution system comprised of component parts including but not limited to cylinders, manifolds, air compressor, motor, receivers, controls, filters, dryers, valves, and piping that delivers compressed air or nitrogen at pressures less than 1100 kPa (less than 160 psi) gauge to power devices (e.g., hand pieces, syringes, cleaning devices) as a power source. (PIP)

**3.3.63\* General Anesthesia and Levels of Sedation/Analgesia.**

**3.3.63.1 Deep Sedation/Analgesia.** A drug-induced depression of consciousness during which patients cannot be easily aroused but respond purposefully following repeated or painful stimulation. The ability to independently maintain ventilatory function may be impaired. Patients may require assistance in maintaining a patent airway, and spontaneous ventilation may be inadequate. Cardiovascular function is usually maintained. (MED)

**3.3.63.2 General Anesthesia.** A drug-induced loss of consciousness during which patients are not arousable, even by painful stimulation. The ability to independently maintain ventilatory function is often impaired. Patients often require assistance in maintaining a patent airway, and positive pressure ventilation may be required because of depressed spontaneous ventilation or drug-induced depression of neuromuscular function. Cardiovascular function may be impaired. (MED)

**3.3.63.3 Minimal Sedation (Anxiolysis).** A drug-induced state during which patients respond normally to verbal commands. Although cognitive function and coordination may be impaired, ventilatory and cardiovascular functions are unaffected. (MED)

**3.3.63.4 Moderate Sedation/Analgesia (Conscious Sedation).** A drug-induced depression of consciousness during which patients respond purposefully to verbal commands, either alone or accompanied by light tactile stimulation. No interventions are required to maintain a patient airway, and spontaneous ventilation is adequate. Cardiovascular function is usually maintained. (MED)

**3.3.64 General Care Area.** See 3.3.138, Patient Care Room.

**3.3.65 Governing Body.** The person or persons who have the overall legal responsibility for the operation of a health care facility. (FUN)

**3.3.66 Ground-Fault Circuit Interrupter (GFCI).** A device intended for the protection of personnel that functions to de-energize a circuit or portion thereof within an established period of time when a current to ground exceeds some predetermined value that is less than that required to operate the overcurrent protective device of the supply circuit. (ELS)

**3.3.67 Grounding.** See 3.3.68, Grounding System.

**3.3.68\* Grounding System.** A system of conductors that provides a low-impedance return path for leakage and fault currents. (ELS)

**3.3.69 Hazard Current.** For a given set of connections in an isolated power system, the total current that would flow through

a low impedance if it were connected between either isolated conductor and ground. (ELS)

**3.3.69.1 Fault Hazard Current.** The hazard current of a given isolated power system with all devices connected except the line isolation monitor. (ELS)

**3.3.69.2 Monitor Hazard Current.** The hazard current of the line isolation monitor alone. (ELS)

**3.3.69.3 Total Hazard Current.** The hazard current of a given isolated system with all devices, including the line isolation monitor, connected. (ELS)

**3.3.70\* Hazardous Chemical.** A chemical with one or more of the following hazard ratings as defined in NFPA 704, *Standard System for the Identification of the Hazards of Materials for Emergency Response* Health — 2, 3, or 4; Flammability — 2, 3, or 4; Reactivity — 2, 3, or 4.

**3.3.71\* Health Care Facilities.** Buildings, portions of buildings, or mobile enclosures in which medical, dental, psychiatric, nursing, obstetrical, or surgical care is provided. (FUN)

**3.3.72 Home Care.** Medical services (equipment) provided in residential occupancies. (FUN)

**3.3.73 Hospital.** A building or portion thereof used on a 24-hour basis for the medical, psychiatric, obstetrical, or surgical care of four or more inpatients. [101, 2012] (FUN)

**3.3.74 Hospital-Based.** In the interpretation and application of this code, physically connected to a hospital. (MED)

**3.3.75 Humidifier.** A device used for adding water vapor to inspired gas. (MED)

**3.3.76 Hyperbaric.** Facility, building, or structure used to house chambers and all auxiliary service equipment for medical applications and procedures at pressures above normal atmospheric pressures. (HYP)

**3.3.77 Hyperbaric Oxygenation.** The application of pure oxygen or an oxygen-enriched gaseous mixture to a subject at elevated pressure. (HYP)

**3.3.78 Hyperbaric Stand-Alone Oxygen System.** The oxygen system is entirely separate from the hospital's Level 1 Oxygen System or is a freestanding hyperbaric facility. (HYP)

**3.3.79 Hypobaric.** Facility, building, or structure used to house chambers and all auxiliary service equipment for medical applications and procedures at pressures below atmospheric pressures. (HYP)

**3.3.80 Hypoxia.** A state of inadequate oxygenation of the blood and tissue sufficient to cause impairment of function. [99B, 2010] (HYP)

**3.3.81 Immediate Restoration of Service.** Automatic restoration of operation with an interruption of not more than 10 seconds. (ELS)

**3.3.82\* Impedance.** Impedance is the ratio of the voltage drop across a circuit element to the current flowing through the same circuit element. The unit of impedance is the ohm. (MED)

**3.3.83 Incident Command System (ICS).** The combination of facilities, equipment, personnel, procedures, and communications operating within a common organizational structure that has responsibility for the management of assigned resources to effectively accomplish stated objectives pertaining to an incident or training exercise. [1670, 2009] (HES)

**3.3.84 Instrument Air.** For the purposes of this code, instrument air is air intended for the powering of medical devices unrelated to human respiration (e.g., surgical tools, ceiling arms). Medical air and instrument air are distinct systems for mutually exclusive applications. Instrument air is a medical support gas that falls under the general requirements for medical gases. (PIP)

**3.3.85 Intermittent Positive-Pressure Breathing (IPPB).** Ventilation of the lungs by application of intermittent positive pressure to the airway. (MED)

**3.3.86\* Intrinsically Safe.** As applied to equipment and wiring, equipment and wiring that are incapable of releasing sufficient electrical energy under normal or abnormal conditions to cause ignition of a specific hazardous atmospheric mixture. (HYP)

**3.3.87 Invasive Procedure.** Any procedure that penetrates the protective surfaces of a patient's body (i.e., skin, mucous membrane, cornea) and that is performed with an aseptic field (procedural site). [Not included in this category are placement of peripheral intravenous needles or catheters used to administer fluids and/or medications, gastrointestinal endoscopies (i.e., sigmoidoscopies), insertion of urethral catheters, and other similar procedures.] (ELS)

**3.3.88 Isolated Patient Lead.** A patient lead whose impedance to ground or to a power line is sufficiently high that connecting the lead to ground, or to either conductor of the power line, results in current flow below a hazardous limit in the lead. (MED)

**3.3.89\* Isolated Power System.** A system comprising an isolation transformer or its equivalent, a line isolation monitor, and its ungrounded circuit conductors. (ELS)

**3.3.90 Isolation Transformer.** A transformer of the multiple-winding type, with the primary and secondary windings physically separated, that inductively couples its ungrounded secondary winding to the grounded feeder system that energizes its primary winding. (ELS)

**3.3.91\* Laboratory.** A building, space, room, or group of rooms intended to serve activities involving procedures for investigation, diagnosis, or treatment in which flammable, combustible, or oxidizing materials are to be used.

**3.3.92\* Laboratory Work Area.** A room or space for testing, analysis, research, instruction, or similar activities that involve the use of chemicals. This work area may or may not be enclosed.

**3.3.93 Leak Detectant.** For purposes of this standard, a reagent, a solution, or an electronic or mechanical device suitable for the detection or visualization of escaping gas. (PIP)

**3.3.94 Life Safety Branch.** A system of feeders and branch circuits supplying power for lighting, receptacles, and equipment essential for life safety that are automatically connected to alternate power sources by one or more transfer switches during interruption of the normal power source. (ELS)

**3.3.95 Limited Care Facility.** A building or portion of a building used on a 24-hour basis for the housing of four or more persons who are incapable of self-preservation because of age; physical limitations due to accident or illness; or limitations such as mental retardation/developmental disability, mental illness, or chemical dependency. [101, 2012] (FUN)

**3.3.96\* Limited-Combustible (Material).** Refers to a building construction material not complying with the definition of *non-combustible material* that, in the form in which it is used, has a

potential heat value not exceeding 8141 kJ/kg (3500 Btu/lb), where tested in accordance with NFPA 259, *Standard Test Method for Potential Heat of Building Materials*, and includes either of the following: (1) materials having a structural base of noncombustible material, with a surfacing not exceeding a thickness of 1/8 in. (3.2 mm) that has a flame spread index not greater than 50; or (2) materials, in the form and thickness used, having neither a flame spread index greater than 25 nor evidence of continued progressive combustion, and of such composition that surfaces that would be exposed by cutting through the material on any plane would have neither a flame spread index greater than 25 nor evidence of continued progressive combustion, when tested in accordance with ASTM E 84, *Standard Test Method for Surface Burning Characteristics of Building Materials*, or ANSI/UL 723, *Standard for Test for Surface Burning Characteristics of Building Materials*. [90A, 2012] (PIP)

**3.3.97 Line Isolation Monitor.** A test instrument designed to continually check the balanced and unbalanced impedance from each line of an isolated circuit to ground and equipped with a built-in test circuit to exercise the alarm without adding to the leakage current hazard. (ELS)

**3.3.98\* Liquid.** Any material that (1) has a fluidity greater than that of 300 penetration asphalt when tested in accordance with ASTM D 5, *Standard Test Method for Penetration of Bituminous Materials*, or (2) is a viscous substance for which a specific melting point cannot be determined but that is determined to be a liquid in accordance with ASTM D 4359, *Standard Test for Determining Whether a Material is a Liquid or a Solid*. [30, 2012] (LAB)

**3.3.99\* Local Signal.** A visible indication of the operating status of equipment. (PIP)

**3.3.100 mA.** Milliampere.

**3.3.101 Manifold.** A device for connecting the outlets of one or more gas cylinders to the central piping system for that specific gas. (PIP)

**3.3.102\* Manufactured Assembly.** A factory-assembled product designed for aesthetics or convenience that contains medical gas or vacuum outlets, piping, or other devices related to medical gases. (PIP)

**3.3.103 Mask.** A device that fits over the mouth and nose (oro-nasal) or nose (nasal) used to administer gases to a patient. (MED)

**3.3.104\* Medical Air.** For purposes of this code, medical air is air supplied from cylinders, bulk containers, or medical air compressors or reconstituted from oxygen USP and oil-free, dry nitrogen NF. (PIP)

**3.3.104.1 Proportioning System for Medical Air USP.** A central supply that produces medical air (USP) reconstituted from oxygen USP and nitrogen NF by means of a mixer or blender. (PIP)

**3.3.105 Medical Air Compressor.** A compressor that is designed to exclude oil from the air stream and compression chamber and that does not under normal operating conditions or any single fault add any toxic or flammable contaminants to the compressed air. (PIP)

**3.3.106\* Medical/Dental Office.** A building or part thereof in which the following occur: (1) examinations and minor treatments/procedures are performed under the continuous supervision of a medical/dental professional; (2) only sedation or



local anesthesia is involved and treatment or procedures do not render the patient incapable of self-preservation under emergency conditions; and (3) overnight stays for patients or 24-hour operation are not provided. (FUN)

**3.3.107 Medical Gas.** A patient medical gas or medical support gas. (See also 3.3.142, *Patient Medical Gas* and 3.3.109, *Medical Support Gas*.) (PIP)

**3.3.108 Medical Gas System.** An assembly of equipment and piping for the distribution of nonflammable medical gases such as oxygen, nitrous oxide, compressed air, carbon dioxide, and helium. (PIP)

**3.3.109 Medical Support Gas.** Nitrogen or instrument air used for any medical support purpose (e.g., to remove excess moisture from instruments before further processing, or to operate medical-surgical tools, air-driven booms, pendants, or similar applications) and, if appropriate to the procedures, used in laboratories and are not respired as part of any treatment. Medical support gas falls under the general requirements for medical gases. (PIP)

**3.3.110 Medical-Surgical Vacuum.** A method used to provide a source of drainage, aspiration, and suction in order to remove body fluids from patients. (PIP)

**3.3.111 Medical-Surgical Vacuum System.** An assembly of central vacuum-producing equipment and a network of piping for patient suction in medical, medical-surgical, and waste anesthetic gas disposal (WAGD) applications. (PIP)

**3.3.112 Multiple Treatment Facility.** A diagnostic or treatment complex under a single management comprising a number of single treatment facilities, which can be accessed one from the other without exiting the facility (i.e., does not involve widely separated locations or separate distinct practices). (FUN)

**3.3.113 mV.** Millivolt.

**3.3.114 Nasal Cannula.** Device consisting of two short tubes to be inserted into the nostrils to administer oxygen or other therapeutic gases. (MED)

**3.3.115 Nasal Catheter.** A flexible tube for insertion through the nose into the nasopharynx to administer oxygen or other therapeutic gases. (MED)

**3.3.116 Nebulizer.** A device used for producing an aerosol of water and/or medication within inspired gas supply. (MED)

**3.3.117 Negative Pressure.** Pressure less than atmospheric. (MED)

**3.3.118 Nitrogen.** An element that, at atmospheric temperatures and pressures, exists as a clear, colorless, and tasteless gas; it comprises approximately four-fifths of the earth's atmosphere. (MED)

**3.3.118.1 Nitrogen NF (Oil-Free, Dry).** Nitrogen complying as a minimum with oil-free, dry nitrogen NF. (PIP)

**3.3.119 Nitrogen Narcosis.** A condition resembling alcoholic inebriation, which results from breathing nitrogen in the air under significant pressure. (HYP)

**3.3.120 Nitrous Oxide.** An inorganic compound, one of the oxides of nitrogen. It exists as a gas at atmospheric pressure and temperature, possesses a sweetish smell, and is used for inducing anesthesia when inhaled. The oxygen in the compound will be released under conditions of combustion, creating an oxygen-enriched atmosphere. (MED)

**3.3.121 Noncombustible (Hyperbaric).** An adjective describing a substance that will not burn in 95 ±5 percent oxygen at pressures up to 3ATA (44.1 psia). (HYP)

**3.3.122 Noncombustible (Hypobaric).** An adjective describing a substance that will not burn in 95 ±5 percent oxygen at pressures of 101.325 kPa (760 mmHg). (HYP)

**3.3.123 Noncombustible (Material).** A material that, in the form in which it is used and under the conditions anticipated, will not ignite, burn, support combustion, or release flammable vapors, when subjected to fire or heat. Materials that are reported as passing ASTM E 136, *Standard Test Method for Behavior of Materials in a Vertical Tube Furnace at 750°C*, shall be considered noncombustible materials. (HYP)

**3.3.124 Nonflammable.** Not readily capable of burning with a flame and not liable to ignite and burn when exposed to flame.

**3.3.125\* Nonflammable Anesthetic Agent.** Refers to those inhalation agents that, because of their vapor pressure at 37°C (98.6°F) and at atmospheric pressure, cannot attain flammable concentrations when mixed with air, oxygen, or mixtures of oxygen and nitrous oxide. (MED)

**3.3.126\* Nonflammable Medical Gas System.** See 3.3.105, Medical Gas System, and Chapter 5.

**3.3.127 Nursing Home.** A building or portion of a building used on a 24-hour basis for the housing and nursing care of four or more persons who, because of mental or physical incapacity, might be unable to provide for their own needs and safety without the assistance of another person. [101, 2012] (FUN)

**3.3.128\* Oxidizing Gas.** A gas that supports combustion. (HYP)

**3.3.129\* Oxygen.** A chemical element that, at normal atmospheric temperatures and pressures, exists as a colorless, odorless, and tasteless gas and comprises about 21 percent by volume of the earth's atmosphere. (MED)

**3.3.129.1 Gaseous Oxygen.** A colorless, odorless, tasteless, and nontoxic gas, comprising about 21 percent of normal air by volume, that is about 10 percent heavier than air; also the physical state of the element at atmospheric temperature and pressure. (MED)

**3.3.129.2\* Liquid Oxygen.** Exists at cryogenic temperature, approximately -184.4°C (-300°F) at atmospheric pressure. It retains all of the properties of gaseous oxygen, but, in addition, when allowed to warm to room temperature at atmospheric pressure, it will evaporate and expand to fill a volume 860 times its liquid volume. (MED)

**3.3.130\* Oxygen Delivery Equipment.** Any device used to transport and deliver an oxygen-enriched atmosphere to a patient. (MED)

**3.3.131 Oxygen-Enriched Atmosphere (OEA).** For the purposes of this code, an atmosphere in which the concentration of oxygen exceeds 23.5 percent by volume. (HYP)

**3.3.132\* Oxygen Hood.** A device encapsulating a patient's head and used for a purpose similar to that of a mask. (See also 3.3.103, *Mask*.) (HYP)

**3.3.133 Oxygen Index.** The minimum concentration of oxygen, expressed as percent by volume, in a mixture of oxygen and nitrogen that will just support combustion of a material under conditions of ASTM D 2863, *Standard Test Method for Measuring the Minimum Oxygen Concentration to Support Candle-Like Combustion of Plastics (Oxygen Index)*. (HYP)

**3.3.134\* Oxygen Toxicity (Hyperbaric).** Physical impairment resulting from breathing gaseous mixtures containing oxygen-enriched atmospheres at elevated partial pressures for extended periods of time. (HYP)

**3.3.135 Oxygen USP.** Oxygen complying with Medical USP.

**3.3.136 Patient Bed Location.** The location of a patient sleeping bed, or the bed or procedure table of a critical care area. (ELS)

**3.3.137 Patient-Care-Related Electrical Equipment.** Electrical equipment appliance that is intended to be used for diagnostic, therapeutic, or monitoring purposes in a patient care vicinity. (MED)

**3.3.138\* Patient Care Room.** Any room of a health care facility wherein patients are intended to be examined or treated. (MED)

**3.3.138.1\* Basic Care Room.** Room in which the failure of equipment or a system is not likely to cause injury to the patients or caregivers but can cause patient discomfort (Category 3). (MED)

**3.3.138.2\* Critical Care Room.** Room in which failure of equipment or a system is likely to cause major injury or death of patients or caregivers (Category 1). (MED)

**3.3.138.3\* General Care Room.** Room in which failure of equipment or a system is likely to cause minor injury to patients or caregivers (Category 2). (MED)

**3.3.138.4\* Support Room.** Room in which failure of equipment or a system is not likely to have a physical impact on patients or caregivers (Category 4). (MED)

**3.3.139 Patient Care Vicinity.** A space, within a location intended for the examination and treatment of patients, extending 1.8 m (6 ft) beyond the normal location of the bed, chair, table, treadmill, or other device that supports the patient during examination and treatment and extending vertically to 2.3 m (7 ft 6 in.) above the floor. (MED)

**3.3.140 Patient Equipment Grounding Point.** A jack or terminal that serves as the collection point for redundant grounding of electric appliances serving a patient care vicinity or for grounding other items in order to eliminate electromagnetic interference problems. (MED)

**3.3.141\* Patient Lead.** Any deliberate electrical connection that can carry current between an appliance and a patient. (MED)

**3.3.142 Patient Medical Gas.** Piped gases such as oxygen, nitrous oxide, helium, carbon dioxide, and medical air that are used in the application of human respiration and the calibration of medical devices used for human respiration. (PIP)

**3.3.143 Piped Distribution System.** A pipeline network assembly of equipment that starts at and includes the source valve, warning systems (master, area, local alarms), bulk gas system signal actuating switch wiring, interconnecting piping, and all other components up to and including the station outlets/inlets. (PIP)

**3.3.144 Piping.** The tubing or conduit of the system. The three general classes of piping are main lines, risers, and branch (lateral) lines. (PIP)

**3.3.144.1 Branch (Lateral) Lines.** Those sections or portions of the piping system that serve a room or group of rooms on the same story of the facility. (PIP)

**3.3.144.2 Main Lines.** The piping that connects the source (pumps, receivers, etc.) to the risers or branches, or both. (PIP)

**3.3.144.3 Risers.** The vertical pipes connecting the system main line(s) with the branch lines on the various levels of the facility. (PIP)

**3.3.145 Plug (Attachment Plug, Cap).** A device that, by insertion in a receptacle, establishes connection between the conductors of the attached flexible cord and the conductors connected permanently to the receptacle. (MED)

**3.3.146 Positive-Negative Pressure Breathing.** Ventilation of the lungs by the application of intermittent positive-negative pressure to the airway. (MED)

**3.3.147 Pressure.**

**3.3.147.1 Absolute Pressure.** The total pressure in a system with reference to zero pressure. (HYP)

**3.3.147.2 Ambient Pressure.** Refers to total pressure of the environment referenced. (HYP)

**3.3.147.3 Gauge Pressure.** Refers to total pressure above (or below) atmospheric. (HYP)

**3.3.147.4 High Pressure.** A pressure exceeding 1.38 kPa (200 psi) gauge (215 psia). (MED)

**3.3.147.5\* Partial Pressure.** The pressure, in absolute units, exerted by a particular gas in a gas mixture. (HYP)

**3.3.147.6 Positive Pressure.** Pressure greater than ambient atmospheric. (MED)

**3.3.147.7\* Working Pressure.** A pressure not exceeding 200 psi (11.6 kg/cm<sup>2</sup>) gauge. (MED)

**3.3.148\* Pressure-Reducing Regulator.** A device that automatically reduces gas under high pressure to a usable lower working pressure. (MED)

**3.3.149 Procedure Room.** Where the proceduralist is using instrumentation that requires constant observation and control. (MED)

**3.3.150 psia.** Pounds per square inch absolute, a unit of pressure measurement with zero pressure as the base or reference pressure. (HYP)

**3.3.151\* psig.** Pounds per square inch gauge, a unit of pressure measurement with atmospheric pressure as the base or reference pressure. (HYP)

**3.3.152 Reactance.** The component of impedance contributed by inductance or capacitance. The unit of reactance is the ohm. (MED)

**3.3.153 Reactive Material.** A material that, by itself, is readily capable of detonation, explosive decomposition, or explosive reaction at normal or elevated temperatures and pressures. [45, 2011]

**3.3.154 Receptacle.** A receptacle is a contact device installed at the outlet for the connection of an attachment plug. A single receptacle is a single contact device with no other contact device on the same yoke. A multiple receptacle is two or more contact devices on the same yoke. [70, 2011] (ELS)

**3.3.155 Reference Grounding Point.** The ground bus of the panelboard or isolated power system panel supplying the patient care room. (MED)

**3.3.156\* Refrigerating Equipment.** Any mechanically operated equipment used for storing below normal ambient temperature hazardous materials having flammability ratings of 3 or 4.

**3.3.157\* Remote.** A Level 3 source of supply that is accessed by exiting the single or multiple treatment facility. (PIP)

**3.3.158 Reserve Supply.** Where existing, that portion of the supply equipment that automatically supplies the system in the event of failure of the operating supply. The reserve supply only functions in an emergency and not as a normal operating procedure. (PIP)

**3.3.159 Safety Can.** An approved container, of not more than 18.9 L (5 gal) capacity, having a spring-closing lid and spout cover and so designed that it will safely relieve internal pressure when subjected to fire exposure.

**3.3.160 Scavenging.** Evacuation of exhaled mixtures of oxygen and nitrous oxide. (PIP)

**3.3.161 SCFM.** Abbreviation of flow rate units of standard cubic feet per minute. (PIP)

**3.3.162 Selected Receptacles.** A minimal number of receptacles selected by the governing body of a facility as necessary to provide essential patient care and facility services during loss of normal power. (ELS)

**3.3.163 Self-Extinguishing.** A characteristic of a material such that, once the source of ignition is removed, the flame is quickly extinguished without the fuel or oxidizer being exhausted. (HYP)

**3.3.164 Semipermanent Connection.** A noninterchangeable connection, usually a D.I.S.S. connector, which is the termination of the pipeline and that is intended to be detached only for service. It is not the point at which the user makes connections or disconnections. (PIP)

**3.3.165 Service Inlet.** The pneumatic terminus of a Level 3 piped vacuum system. (PIP)

**3.3.166 Service Outlet.** The pneumatic terminus of a piped gas system for other than critical, continuous duty, nonflammable medical life support-type gases such as oxygen, nitrous oxide, or medical air. (PIP)

**3.3.167\* Single Treatment Facility.** A diagnostic or treatment complex under a single management comprising a number of use points, but confined to a single contiguous group of use points (i.e., does not involve widely separated locations or separate distinct practices). (PIP)

**3.3.168\* Site of Intentional Expulsion.** All points within 0.3 m (1 ft) of a point at which an oxygen-enriched atmosphere is intentionally vented to the atmosphere. (MED)

**3.3.169 Station Inlet.** An inlet point in a piped medical/surgical vacuum distribution system at which the user makes connections and disconnections. (PIP)

**3.3.170 Station Outlet.** An outlet point in a piped medical gas distribution system at which the user makes connections and disconnections. (PIP)

**3.3.171 Supply Source.**

**3.3.171.1 Operating Supply.** The portion of the supply system that normally supplies the piping systems. The operating supply consists of a primary supply or a primary and secondary supply. (PIP)

**3.3.171.2 Primary Supply.** That portion of the source equipment that actually supplies the system. (PIP)

**3.3.171.3 Reserve Supply.** Where provided, that portion of the source equipment that automatically supplies the system in the event of failure of the primary and secondary operating supply. (PIP)

**3.3.171.4 Secondary Supply.** Where provided, that portion of the source equipment that automatically supplies the system when the primary supply becomes exhausted. (PIP)

**3.3.172\* Surface-Mounted Medical Gas Rail Systems.** A surface-mounted gas delivery system intended to provide ready access for two or more gases through a common delivery system to provide multiple gas station outlet locations within a single patient room or critical care area. (PIP)

**3.3.173 Task Illumination.** Provisions for the minimum lighting required to carry out necessary tasks in the areas described in Chapter 6, including safe access to supplies and equipment and access to exits. (ELS)

**3.3.174 Terminal.** The end of a flexible hose or tubing used in a manufactured assembly where the user is intended to make connection and disconnection. (PIP)

**3.3.175 Touch Current.** Leakage current flowing from the enclosure or from parts thereof, excluding patient connections, accessible to any operator or patient in normal use, through an external path other than the protective grounding (earth) conductor to earth or to another part of the enclosure. (MED)

**3.3.176 Transfilling.** The process of transferring a medical gas in gaseous or liquid state from one container or cylinder to another container or cylinder (MED).

**3.3.177 Tube.**

**3.3.177.1\* Endotracheal Tube.** A tube for insertion through the mouth or nose into the upper portion of the trachea (windpipe). (MED)

**3.3.177.2\* Tracheotomy Tube.** A curved tube for insertion into the trachea (windpipe) below the larynx (voice box) during the performance of an appropriate operative procedure (tracheotomy). (MED)

**3.3.178\* Unattended Laboratory Operation.** A laboratory procedure or operation at which there is no person present who is knowledgeable regarding the operation and emergency shutdown procedures. [45, 2011]

**3.3.179 Use Point.** A location with any number of station outlets and inlets arranged for access by a practitioner during treatment of a patient. (PIP)

**3.3.180\* Utility Center (J Box).** A type of terminal enclosure for utilities (e.g., gas power, vacuum, water, electrical power) used in office-based occupancies. (PIP)

**3.3.181 Vaporizer.** A heat exchange unit designed to convert cryogenic liquid into the gaseous state. (PIP)

**3.3.182\* WAGD Interface.** A device provided on the anesthesia gas machine that connects the WAGD network to the patient breathing circuit. (PIP)

**3.3.183 Waste Anesthetic Gas Disposal (WAGD).** The process of capturing and carrying away gases vented from the patient breathing circuit during the normal operation of gas anesthesia or analgesia equipment. (PIP)

**3.3.184\* Wet Procedure Locations.** The area in a patient care room where a procedure is performed that is normally subject to wet conditions while patients are present, including standing fluids on the floor or drenching of the work area, either of which condition is intimate to the patient or staff. (FUN)

**3.4 BICSI Definitions.** These terms are defined in *The BICSI Information Transport Systems (ITS) Dictionary*. (HES)

**3.4.1 Telecommunications Entrance Facility (EF).** An entrance to a building for both public and private network service cables that includes the building entrance point and the entrance room or space at the point of demarcation between campus or utility service and building interior distribution of communications systems. (ELS)

**3.4.2 Telecommunications Equipment Room (TER).** An environmentally controlled centralized space for telecommunications equipment, typically including main or intermediate cross-connect equipment and cabling. (ELS)

**3.4.3 Telecommunications Room (TR).** An enclosed architectural space for housing telecommunications equipment, cable terminations, and cross-connect cabling, serving a floor or an area of a floor. (ELS)

## Chapter 4 Fundamentals

**4.1\* Building System Categories.** Building systems in health care facilities shall be designed to meet system Category 1 through Category 4 requirements as detailed in this code.

**4.1.1\* Category 1.** Facility systems in which failure of such equipment or system is likely to cause major injury or death of patients or caregivers shall be designed to meet system Category 1 requirements as defined in this code.

**4.1.2\* Category 2.** Facility systems in which failure of such equipment is likely to cause minor injury to patients or caregivers shall be designed to meet system Category 2 requirements as defined in this code.

**4.1.3 Category 3.** Facility systems in which failure of such equipment is not likely to cause injury to patients or caregivers, but can cause patient discomfort, shall be designed to meet system Category 3 requirements as defined in this code.

**4.1.4 Category 4.** Facility systems in which failure of such equipment would have no impact on patient care shall be designed to meet system Category 4 requirements as defined in this code.

**4.2\* Risk Assessment.** Categories shall be determined by following and documenting a defined risk assessment procedure.

**4.3 Application.** The Category definitions in Chapter 4 shall apply to Chapters 5 through 11.

## Chapter 5 Gas and Vacuum Systems

### 5.1 Category 1 Piped Gas and Vacuum Systems.

#### 5.1.1\* Applicability.

**5.1.1.1** These requirements shall apply to health care facilities that require Category 1 systems as referenced in Chapter 4.

**5.1.1.2\*** Where the terms *medical gas* or *medical support gas* occur, the provisions shall apply to all piped systems for oxygen, nitrous oxide, medical air, carbon dioxide, helium, nitrogen, instrument

air, and mixtures thereof. Wherever the name of a specific gas service occurs, the provision shall apply only to that gas.

**5.1.1.3** Wherever the term *medical-surgical vacuum* occurs, the provisions shall apply to systems for piped medical-surgical vacuum and piped waste anesthetic gas disposal (WAGD). Wherever the name of a specific vacuum service occurs, the provision shall apply only to that vacuum service.

**5.1.1.4** An existing system that is not in strict compliance with the provisions of this code shall be permitted to be continued in use as long as the authority having jurisdiction has determined that such use does not constitute a distinct hazard to life.

**5.1.1.5** Subsection 5.1.2 through 5.1.12.3.14.5 and 5.1.14.4.2 shall apply to new health care facilities or facilities making changes that alter the piping.

**5.1.1.6** Paragraph 5.1.14.4.3 through 5.1.14.4.9 and 5.1.13 through 5.1.15 shall apply to existing health care facilities.

**5.1.1.7** Paragraph 5.1.14.3 and 5.1.14.4.1 shall apply to new and existing health care facilities.

**5.1.2 Nature of Hazards of Gas and Vacuum Systems.** Potential fire and explosion hazards associated with positive pressure gas central piping systems and medical-surgical vacuum systems shall be considered in the design, installation, testing, operation, and maintenance of these systems.

#### 5.1.3\* Category 1 Sources.

##### 5.1.3.1 Central Supply System Identification and Labeling.

**5.1.3.1.1\*** Containers, cylinders, and tanks shall be designed, fabricated, tested, and marked (stamped) in accordance with regulations of DOT, Transport Canada (TC) *Transportation of Dangerous Goods Regulations*, or the ASME *Boiler and Pressure Vessel Code*, "Rules for the Construction of Unfired Pressure Vessels," Section VIII. [55:7.1.5.1]

**5.1.3.1.2** Cylinder contents shall be identified by attached labels or stencils naming the contents in accordance with CGA C-7, *Guide to the Preparation of Precautionary Labeling and Marking of Compressed Gas Containers*.

**5.1.3.1.3** Liquid containers shall have additional product identification visible from all directions with a minimum of 51 mm (2 in.) high letters such as a 360-degree wraparound tape for medical liquid containers.

**5.1.3.1.4** Cryogenic liquid containers shall be provided with gas-specific outlet connections in accordance with CGA V-5, *Diameter-Index Safety System (Noninterchangeable Low Pressure Connections for Medical Gas Applications)*, or CGA V-1, *Compressed Gas Association Standard for Compressed Gas Cylinder Valve Outlet and Inlet Connections*.

**5.1.3.1.5** Cylinder and cryogenic liquid container outlet connections shall be affixed in such a manner as to be integral to the valve(s), unremovable with ordinary tools, or so designed as to render the attachment point unusable when removed.

**5.1.3.1.6** The contents of cylinders and cryogenic liquid containers shall be verified prior to use.

**5.1.3.1.7** Labels shall not be defaced, altered, or removed, and connecting fittings shall not be modified.

**5.1.3.1.8** Locations containing positive pressure gases other than oxygen and medical air shall have their door(s) labeled as follows:

**Positive Pressure Gases  
NO Smoking or Open Flame  
Room May Have Insufficient Oxygen  
Open Door and Allow Room to  
Ventilate Before Entering**

**5.1.3.1.9** Locations containing central supply systems or cylinders containing only oxygen or medical air shall have their door(s) labeled as follows:

**Medical Gases  
NO Smoking or Open Flame**

**5.1.3.2 Central Supply System Operations.**

**5.1.3.2.1** The use of adapters or conversion fittings to adapt one gas-specific fitting to another shall be prohibited.

**5.1.3.2.2** Cylinders and containers shall be handled in strict accordance with 11.6.2.

**5.1.3.2.3** Only gas cylinders, reusable shipping containers, and their accessories shall be permitted to be stored in rooms containing central supply systems or gas cylinders.

**5.1.3.2.4** No flammable materials, cylinders containing flammable gases, or containers containing flammable liquids shall be stored in rooms with gas cylinders.

**5.1.3.2.5** If cylinders are wrapped when received, the wrappers shall be removed prior to storage.

**5.1.3.2.6** Cylinders without correct markings or whose markings and gas-specific fittings do not match shall not be used.

**5.1.3.2.7** Cryogenic liquid storage units intended to supply gas to the facility shall not be used to transfill other liquid storage vessels.

**5.1.3.2.8** Care shall be exercised when handling cylinders that have been exposed to freezing temperatures or containers that contain cryogenic liquids to prevent injury to the skin.

**5.1.3.2.9** Cylinders containing compressed gases and containers for volatile liquids shall be kept away from radiators, steam piping, and like sources of heat.

**5.1.3.2.10** When cylinder valve protection caps are supplied, they shall be secured tightly in place unless the cylinder is connected for use.

**5.1.3.2.11** Containers shall not be stored in a tightly closed space.

**5.1.3.3\* Central Supply System Locations.**

**5.1.3.3.1 General.** Central supply systems shall be located to meet the criteria in 5.1.3.3.1.1 through 5.1.3.3.1.12.

**5.1.3.3.1.1** Any of the following systems shall be permitted to be located together in the same outdoor enclosure:

- (1) Manifolds for gas cylinders without reserve supply (*see 5.1.3.5.10*)
- (2) Manifolds for gas cylinders with reserve supply
- (3) Manifolds for cryogenic liquid containers (*see 5.1.3.5.12*)
- (4) Bulk cryogenic liquid systems (*see 5.1.3.5.13*)

**5.1.3.3.1.2** Any of the following systems shall be permitted to be located together in the same indoor enclosure:

- (1) Manifolds for gas cylinders without reserve supply (*see 5.1.3.5.10*)
- (2) Manifolds for gas cylinders with reserve supply
- (3) Manifolds for cryogenic liquid containers (*see 5.1.3.5.12*)
- (4) In-building emergency reserves (*see 5.1.3.5.14*)
- (5) Instrument air standby headers (*see 5.1.3.9.5*)

**5.1.3.3.1.3** Any of the following systems shall be permitted to be located together in the same room:

- (1) Medical air compressor supply sources (*see 5.1.3.6.3*)
- (2) Medical-surgical vacuum sources (*see 5.1.3.7*)
- (3) Waste anesthetic gas disposal (WAGD) sources (*see 5.1.3.8*)
- (4) Instrument air compressor sources (*see 5.1.3.9*)
- (5) Any other compressor, vacuum pump, or electrically powered machinery

**5.1.3.3.1.4** Any system listed under 5.1.3.3.1.3 shall not be located in the same room with any system listed under 5.1.3.3.1.1 or 5.1.3.3.1.2, except instrument air reserve headers complying with 5.1.3.3.1.7 and 5.1.3.9.5 shall be permitted to be in the same room as an instrument air compressor.

**5.1.3.3.1.5** Locations shall be chosen to allow access by delivery vehicles and management of cylinders (e.g., proximity to loading docks, access to elevators, and passage of cylinders through public areas).

**5.1.3.3.1.6** Indoor locations for oxygen, nitrous oxide, and mixtures of these gases shall not communicate with the following:

- (1) Areas involved in critical patient care
- (2) Anesthetizing locations where moderate sedation, deep sedation, or general anesthesia is administered
- (3) Locations storing flammables
- (4) Rooms containing open electrical contacts or transformers
- (5) Storage tanks for flammable or combustible liquids
- (6) Engines
- (7) Kitchens
- (8) Areas with open flames

**5.1.3.3.1.7** Cylinders in use and in storage shall be prevented from reaching temperatures in excess of 54°C (130°F).

**5.1.3.3.1.8** Central supply systems for nitrous oxide and carbon dioxide using cylinders or portable containers shall be prevented from reaching temperatures lower than the recommendations of the central supply system's manufacturer, but shall never be lower than -29°C (-20°F) or greater than 51.6°C (125°F).

**5.1.3.3.1.9** Central supply systems for oxygen with a total capacity connected and in storage of 566,335 L (20,000 ft<sup>3</sup>) or more outside of the facility at standard temperature and pressure (STP) shall comply with NFPA 55, *Compressed Gases and Cryogenic Fluids Code*.

**5.1.3.3.1.10** Central supply systems for nitrous oxide with a total capacity connected and in storage of 1451 kg (3200 lb) or more shall comply with CGA G-8.1, *Standard for Nitrous Oxide Systems at Consumer Sites*.

**5.1.3.3.1.11** Central supply systems for carbon dioxide using permanently installed containers with product capacities greater than 454 kg (1000 lb) shall comply with CGA G-6.1, *Standard for Insulated Carbon Dioxide Systems at Consumer Sites*.

**5.1.3.3.1.12** Central supply systems for carbon dioxide using permanently installed containers with product capacities of 454 kg (1000 lb) or less shall comply with CGA G-6.5, *Standard for Small, Stationary, Insulated Carbon Dioxide Supply Systems*.

**5.1.3.3.1.13\*** Central supply systems for bulk inert gases systems with a total capacity connected and in storage of 20,000 ft<sup>3</sup> or more of compressed gas or cryogenic fluid at standard temperature and pressure, shall comply with CGA P-18, *Standard for Bulk Inert Gas Systems at Consumer Sites*.

**5.1.3.3.2\* Design and Construction.** Locations for central supply systems and the storage of positive-pressure gases shall meet the following requirements:

- (1) They shall be constructed with access to move cylinders, equipment, and so forth, in and out of the location on hand trucks complying with 11.4.3.1.1.
- (2) They shall be secured with lockable doors or gates or otherwise secured.
- (3) If outdoors, they shall be provided with an enclosure (wall or fencing) constructed of noncombustible materials with a minimum of two entry/exits.
- (4) If indoors, they shall be constructed and use interior finishes of noncombustible or limited-combustible materials such that all walls, floors, ceilings, and doors are of a minimum 1-hour fire resistance rating.
- (5)\*They shall be compliant with *NFPA 70, National Electrical Code*, for ordinary locations.
- (6) They shall be heated by indirect means (e.g., steam, hot water) if heat is required.
- (7) They shall be provided with racks, chains, or other fastenings to secure all cylinders from falling, whether connected, unconnected, full, or empty.
- (8)\*They shall be supplied with electrical power compliant with the requirements for essential electrical systems as described in Chapter 6.
- (9) They shall have racks, shelves, and supports, where provided, constructed of noncombustible materials or limited-combustible materials.
- (10) They shall protect electrical devices from physical damage.

#### **5.1.3.3.3 Ventilation.**

**5.1.3.3.3.1 Venting of Relief Valves.** Indoor supply systems shall have all relief valves vented per 5.1.3.5.6.1(4) through (9).

**5.1.3.3.3.2 Ventilation for Motor-Driven Equipment.** The following source locations shall be adequately ventilated to prevent accumulation of heat:

- (1) Medical air sources (*see 5.1.3.6*)
- (2) Medical-surgical vacuum sources (*see 5.1.3.7*)
- (3) Waste anesthetic gas disposal (WAGD) sources (*see 5.1.3.8.1*)
- (4) Instrument air sources (*see 5.1.3.9*)

#### **5.1.3.3.3.3 Ventilation for Outdoor Locations.**

**(A)** Outdoor locations surrounded by impermeable walls shall have protected ventilation openings located at the base of each wall to allow free circulation of air within the enclosure.

**(B)** Walls that are shared with other enclosures or with buildings shall be permitted to not have openings.

#### **5.1.3.3.4 Storage.**

**5.1.3.3.4.1** Full or empty medical gas cylinders, when not connected, shall be stored in locations complying with 5.1.3.3.2 through 5.1.3.3.3 and shall be permitted to be in the same rooms or enclosures as their respective central supply systems.

**5.1.3.3.4.2** Cylinders, whether full or empty, shall not be stored in enclosures containing motor-driven machinery, with the exception of cylinders intended for instrument air reserve headers complying with 5.1.3.9.5, which shall be permitted to be placed

in the same location containing an instrument air compressor when it is the only motor-driven machinery located within the room. Only cylinders intended for instrument air reserve headers complying with 5.1.3.9.5 shall be permitted to be stored in enclosures containing instrument air compressors.

**5.1.3.4 Control Equipment.** For control equipment, as specified in 5.1.3.5.5, 5.1.3.5.6, and 5.1.3.5.7, that is physically remote from the supply system, the control equipment shall be installed within a secure enclosure to prevent unauthorized access in accordance with 5.1.3.3.2(2).

**5.1.3.4.1** The enclosure shall provide enough space to perform maintenance and repair.

**5.1.3.4.2** The location of the enclosure for control equipment other than for medical air shall not communicate with combustible or flammable materials.

**5.1.3.5\* Central Supply Systems.** Central supply systems shall be permitted to consist of the following:

- (1) Cylinder manifolds for gas cylinders per 5.1.3.5.10
- (2) Manifolds for cryogenic liquid containers per 5.1.3.5.12
- (3) Bulk cryogenic liquid systems per 5.1.3.5.13
- (4) Medical air compressor systems per 5.1.3.6
- (5) Medical-surgical vacuum producers per 5.1.3.7
- (6) WAGD producers per 5.1.3.8
- (7) Instrument air compressor systems per 5.1.3.9
- (8) Proportioning systems for medical air USP per 5.1.3.6.3.4

**5.1.3.5.1 General.** Central supply systems shall be obtained from a supplier or manufacturer familiar with their proper construction and use and installed in accordance with the manufacturer's instructions.

**5.1.3.5.2 Permitted Locations for Medical Gases.** Central supply systems and medical gas outlets for oxygen, medical air, nitrous oxide, carbon dioxide, and all other patient medical gases shall be piped only into areas where the gases will be used under the direction of licensed medical professionals for purposes congruent with the following:

- (1) Direct respiration by patients
- (2) Clinical application of the gas to a patient, such as the use of an insufflator to inject carbon dioxide into patient body cavities during laparoscopic surgery and carbon dioxide used to purge heart-lung machine blood flow ways
- (3) Medical device applications directly related to respiration
- (4) Power for medical devices used directly on patients
- (5) Calibration of medical devices intended for (1) through (4)

**5.1.3.5.3 Support Gases.** Central supply systems for support gases shall not be piped to, or used for, any purpose except medical support application.

**5.1.3.5.4\* Materials.** Materials used in central supply systems shall meet the following requirements:

- (1) In those portions of systems intended to handle oxygen at gauge pressures greater than 2413 kPa (350 psi), interconnecting hose shall contain no polymeric materials.
- (2) In those portions of systems intended to handle oxygen or nitrous oxide material, construction shall be compatible with oxygen under the temperatures and pressures to which the components can be exposed in the containment and use of oxygen, nitrous oxide, mixtures of these gases, or mixtures containing more than 23.5 percent oxygen.
- (3) If potentially exposed to cryogenic temperatures, materials shall be designed for low temperature service.
- (4) If intended for outdoor installation, materials shall be installed per the manufacturer's requirements.

### 5.1.3.5.5 Final Line Pressure Regulators.

5.1.3.5.5.1 All positive pressure supply systems shall be provided with duplex line pressure regulators piped in parallel with the following characteristics:

- (1) They shall be provided with isolation valves on the source side of each regulator.
- (2) They shall be provided with isolation or check valves on the patient side of each regulator.
- (3) A pressure indicator(s) shall be located downstream (patient or use side) of each regulator or immediately downstream of the isolating valves for the regulators.
- (4) They shall be piped to allow either regulator to be serviced without interrupting supply.
- (5) Each regulator shall be sized for 100 percent of the peak calculated demand.
- (6) They shall be constructed of materials deemed suitable by the manufacturer.

5.1.3.5.5.2 The line pressure regulators required under 5.1.3.5.5.1, when used for bulk cryogenic liquid systems, shall be of a balanced design.

### 5.1.3.5.6 Relief Valves.

5.1.3.5.6.1 All pressure relief valves shall meet the following requirements:

- (1) They shall be of brass, bronze, or stainless steel construction.
- (2) They shall be designed for the specific gas service.
- (3) They shall have a relief pressure setting not higher than the maximum allowable working pressure (MAWP) of the component with the lowest working pressure rating in the portion of the system being protected.
- (4) They shall be vented to the outside of the building, except that relief valves for compressed air systems having less than 84,950 L (3000 ft<sup>3</sup>) at STP shall be permitted to be diffused locally by means that will not restrict the flow.
- (5) They shall have a vent discharge line that is not smaller than the size of the relief valve outlet.
- (6) Where two or more relief valves discharge into a common vent line, its internal cross-sectional area shall be not less than the aggregate cross-sectional area of all relief valve vent discharge lines served.
- (7) They shall not discharge into locations creating potential hazards.
- (8) They shall have the discharge terminal turned down and screened to prevent the entry of rain, snow, or vermin.
- (9) They shall be designed in accordance with ASME B31.3, *Pressure Process Piping*.

5.1.3.5.6.2 When vented to outdoors, materials and construction for relief valve discharge lines shall be the same as required for positive pressure gas distribution. (See 5.1.10.1.)

5.1.3.5.6.3 Central supply systems for positive pressure gases shall include one or more relief valves, all meeting the following requirements:

- (1) They shall be located between each final line regulator and the source valve.
- (2) They shall have a relief setting that is 50 percent above the normal system operating pressure, as indicated in Table 5.1.11.

5.1.3.5.6.4 When vented outside, relief valve vent lines shall be labeled in accordance with 5.1.11.1 in any manner that will distinguish them from the medical gas pipeline.

5.1.3.5.7 Multiple Pressures. Where a single central supply system supplies separate piped distribution networks operating at different pressures, each piped distribution network shall comply with the following:

- (1) Medical air compressor systems: 5.1.3.5.9 (pressure regulators) and 5.1.9.2.4(7) (master alarm)
- (2) All central supply systems: 5.1.3.5.5 (pressure regulators), 5.1.3.5.6 (relief valves), 5.1.4.4 (source valve), and 5.1.9.2.4(7) (master alarm)

### 5.1.3.5.8 Local Signals.

5.1.3.5.8.1 The following systems shall have local signals located at the source equipment:

- (1) Manifolds for gas cylinders without reserve supply (see 5.1.3.5.10)
- (2) Manifolds for gas cylinders with reserve supply
- (3) Manifolds for cryogenic liquid containers (see 5.1.3.5.12)
- (4) Bulk cryogenic liquid systems (see 5.1.3.5.13)
- (5) In-building emergency reserves (see 5.1.3.5.14)
- (6) Instrument air headers (see 5.1.3.5.9)

5.1.3.5.8.2 The local signals shall meet the following requirements:

- (1) Provision of visual indication only
- (2) Labeling for the service and condition being monitored
- (3) If intended for outdoor installation, be installed per manufacturer's requirements

5.1.3.5.9\* Headers. In central supply systems using cylinders containing either gas or liquid, each header shall include the following:

- (1)\*Cylinder connections in the number required for the header's application
- (2) Cylinder lead for each cylinder constructed of materials complying with 5.1.3.5.4 and provided with end fittings permanently attached to the cylinder lead complying with CGA V-1, *Compressed Gas Association Standard for Compressed Gas Cylinder Valve Outlet and Inlet Connections* (ANSI B57.1)
- (3) Filter of a material complying with 5.1.3.5.4 to prevent the intrusion of debris into the manifold controls
- (4) Header shutoff valve downstream of the nearest cylinder connection, but upstream of the point at which the header connects to the central supply system
- (5) Pressure indicator indicating the pressure of header contents
- (6) Check valve to prevent backflow into the header and to allow service to the header
- (7) If intended for gas cylinder service, a check valve at each connection for the cylinder lead in 5.1.3.5.9(2) to prevent loss of gas in the event of damage to the cylinder lead or operation of an individual cylinder relief valve
- (8) If intended for gas cylinder service, a pressure regulator to reduce the cylinder pressure to an intermediate pressure to allow the proper operation of the primary and secondary headers
- (9) If intended for service with cryogenic liquid containers, a pressure relief valve
- (10) Vent valves, if fitted on a header, vented outside of the building per 5.1.3.5.6.1(5) through 5.1.3.5.6.1(9) and 5.1.3.5.6.2

5.1.3.5.10\* Manifolds for Gas Cylinders Without Reserve Supply.

**5.1.3.5.10.1** The manifolds in this category shall be located in accordance with 5.1.3.3.1 and shall meet the following:

- (1) If located outdoors, they shall be installed in an enclosure used only for this purpose and sited to comply with minimum distance requirements in NFPA 55.
- (2) If located indoors, they shall be installed within a room used only for enclosure of such manifolds.

**5.1.3.5.10.2** The manifold locations for this category shall be constructed in accordance with 5.1.3.3.2.

**5.1.3.5.10.3** The manifold locations for this category shall be ventilated in accordance with 5.1.3.3.3.

**5.1.3.5.10.4** The manifolds in this category shall consist of the following:

- (1) Two equal headers in accordance with 5.1.3.5.9, each with a sufficient number of gas cylinder connections for an average day's supply, but not fewer than two connections, and with the headers connected to the final line pressure regulator assembly in such a manner that either header can supply the system
- (2) Vent valves, if fitted on a header, vented outside of the building per 5.1.3.5.6.1(5) through (9) and 5.1.3.5.6.2
- (3) Intermediate relief valve(s), piped to the outside in accordance with 5.1.3.5.6.1(5) through (9), that protects the piping between the header pressure regulator and the line pressure regulator assembly, and protects the line pressure regulators from overpressure in the event of a header regulator failure

**5.1.3.5.10.5** The manifolds in this category shall include an automatic means of alternating the two headers to accomplish the following in normal operation:

- (1) One header is the primary and the other is the secondary, with either being capable of either role.
- (2) When the primary header is supplying the system, the secondary header is prevented from supplying the system.
- (3) When the primary header is depleted, the secondary header automatically begins to supply the system.

**5.1.3.5.10.6** The manifolds in this category shall have a local signal that visibly indicates the operating status of the equipment and shall activate an indicator at all master alarm panels when or at a predetermined set point before the secondary header begins to supply the system, indicating changeover has occurred or is about to occur.

**5.1.3.5.10.7** If manifolds are located out of doors, they shall be installed per the manufacturer's requirements.

**5.1.3.5.11\* Manifolds for Cryogenic Liquid Containers.**

**5.1.3.5.11.1** Manifolds for cryogenic liquid containers shall be located in accordance with 5.1.3.3.1 and shall meet the following:

- (1) If located outdoors, they shall be installed in an enclosure used only for the enclosure of such containers. [See Figure A.5.1.3.5.12(a) for minimum citing distance requirements.]
- (2) If located indoors, they shall be installed within a room used only for the enclosure of such containers.

**5.1.3.5.11.2** The manifolds in this category shall have their primary and secondary headers located in the same enclosure.

**5.1.3.5.11.3** The reserve header shall be permitted to be located in the same enclosure as the primary and secondary headers or in another enclosure compliant with 5.1.3.5.11.1.

**5.1.3.5.11.4** The manifolds in this category shall consist of the following:

- (1) Two equal headers per 5.1.3.5.9, each having sufficient number of liquid container connections for an average day's supply, and with the headers connected to the final line pressure regulator assembly in such a manner that either header can supply the system
- (2) Reserve header per 5.1.3.5.9 having sufficient number of gas cylinder connections for an average day's supply, but not fewer than three connections, and connected downstream of the primary/secondary headers and upstream of the final line pressure regulators
- (3) Pressure relief installed downstream of the connection of the reserve header and upstream of the final line pressure regulating assembly and set at 50 percent above the nominal inlet pressure

**5.1.3.5.11.5** The manifolds in this category shall include an automatic means of controlling the three headers to accomplish the following during normal operation:

- (1) If provided with two liquid container headers, one cryogenic liquid header is the primary and the other is the secondary, with either being capable of either role.
- (2) If provided with one liquid container header and one gas cylinder header (a hybrid arrangement), the liquid container header is the primary and the gas cylinder header is the secondary.
- (3) When the primary header is supplying the system, the secondary header is prevented from supplying the system.
- (4) When the primary header is depleted, the secondary header automatically begins to supply the system.

**5.1.3.5.11.6** The manifolds in this category shall be equipped with a means to conserve the gas produced by evaporation of the cryogenic liquid in the secondary header (when so provided). This mechanism shall discharge the conserved gas into the system upstream of the final line regulator assembly.

**5.1.3.5.11.7** The manifolds in this category shall include a manual or automatic means to place either header into the role of primary header and the other into the role of secondary header, except where a liquid/gas hybrid manifold is employed.

**5.1.3.5.11.8** The manifolds in this category shall include a means to automatically activate the reserve header if for any reason the primary and secondary headers cannot supply the system.

**5.1.3.5.11.9** The manifolds in this category shall have a local signal that visibly indicates the operating status of the equipment and activates an indicator at all master alarms under the following conditions:

- (1) When or at a predetermined set point before the secondary header begins to supply the system, indicating changeover
- (2) Where a hybrid arrangement is employed, when or at a predetermined set point before the secondary (cylinder) header contents fall to one day's average supply, indicating secondary low
- (3) When or at a predetermined set point before the reserve header begins to supply the system, indicating reserve is in use
- (4) When or at a predetermined set point before the reserve header contents fall to one day's average supply, indicating reserve low



**5.1.3.5.12\* Bulk Cryogenic Liquid Systems.**

**5.1.3.5.12.1** Bulk cryogenic liquid storage systems shall be in accordance with NFPA 55, *Compressed Gases and Cryogenic Fluids Code*.

**5.1.3.5.12.2** Bulk cryogenic liquid systems shall have the following protections:

- (1) Be installed in accordance with NFPA 55, *Compressed Gases and Cryogenic Fluids Code*
- (2) Meet the requirements of 5.1.3.3.2(1)
- (3) Meet the requirements of 5.1.3.3.2(8)
- (4) Meet the requirements of 5.1.3.3.2(10)
- (5) Be installed meeting the requirements in 5.1.10.1 through 5.1.10.4.7
- (6) Have a minimum work space clearance of 3 ft (1 m) around the storage container, vaporizer(s), and the cabinet opening or front side of the pressure regulating manifold for system maintenance and operation

**5.1.3.5.12.3** Bulk cryogenic liquid sources shall include automatic means to provide the following functions:

- (1) When the main supply is supplying the system, the reserve supply shall be prevented from supplying the system until the main supply is reduced to a level at or below the reserve activation pressure.
- (2) When the main supply cannot supply the system, the reserve supply shall automatically begin to supply the system.
- (3) Where there is more than one main supply vessel, the system shall operate as described in 5.1.3.5.11 for primary, secondary, and reserve operation.
- (4) Where there are two or more cryogenic vessels, they shall be permitted to alternate (e.g., on a timed basis) in the roles of primary, secondary, and reserve, provided that an operating cascade (primary–secondary–reserve) as required in 5.1.3.5.11.4 is maintained at all times.
- (5) Where a cryogenic vessel is used as the reserve, the reserve vessel shall include a means to conserve the gas produced by evaporation of the cryogenic liquid in the reserve vessel and to discharge the gas into the line upstream of the final line regulator assembly as required by 5.1.3.5.11.6.

**5.1.3.5.12.4\*** The bulk systems shall have a local signal that visibly indicates the operating status of the equipment and an indicator at all master alarms under the following conditions:

- (1) When or at a predetermined set point before the main supply reaches an average day's supply, indicating low contents
- (2) When or at a predetermined set point before the reserve supply begins to supply the system, indicating reserve is in use
- (3) When or at a predetermined set point before the reserve supply contents fall to one day's average supply, indicating reserve low
- (4) If the reserve is a cryogenic vessel, when or at a predetermined set point before the reserve internal pressure falls too low for the reserve to operate properly, indicating reserve failure
- (5) Where there is more than one main supply vessel, when or at a predetermined set point before the secondary vessel begins to supply the system, indicating changeover

**5.1.3.5.13\* Emergency Oxygen Supply Connection (EOSC).** Emergency oxygen supply connections (EOSCs) shall be installed to allow connection of a temporary auxiliary source of supply for emergency or maintenance situations where any of the following conditions exist:

- (1) The bulk cryogenic liquid central supply system is outside of and remote from the building that the oxygen supply serves.

- (2) There is no connected oxygen reserve sufficient for an average day's supply within the building. (*see 5.1.3.5.14 for requirements for such reserves*).
- (3) Multiple freestanding buildings are served from a single oxygen source such that damage to the interconnecting oxygen line could result in one or more buildings losing oxygen supply, in which case each building is required to be provided with a separate emergency connection.

**5.1.3.5.13.1** EOSCs shall be located as follows:

- (1) Located on the exterior of the building being served in a location accessible by emergency supply vehicles at all times in all weather conditions
- (2) Connected to the main supply line immediately downstream of the main shutoff valve

**5.1.3.5.13.2** EOSCs shall consist of the following:

- (1) Physical protection to prevent unauthorized tampering
- (2) Female DN (NPS) inlet for connection of the emergency oxygen source that is sized for 100 percent of the system demand at the emergency source gas pressure
- (3) Manual shutoff valve to isolate the EOSC when not in use
- (4) Two check valves, one downstream of the EOSC and one downstream of the main line shutoff valve, with both upstream from the tee connection for the two pipelines
- (5) Relief valve sized to protect the downstream piping system and related equipment from exposure to pressures in excess of 50 percent higher than normal line pressure
- (6) Any valves necessary to allow connection of an emergency supply of oxygen and isolation of the piping to the normal source of supply
- (7) Minimum of 1 m (3 ft) of clearance around the EOSC for connection of temporary auxiliary source

**5.1.3.5.14 In-Building Emergency Reserves.**

**5.1.3.5.14.1** In-building emergency reserves shall not be used as substitutes for the bulk gas reserves that are required in 5.1.3.5.12.4.

**5.1.3.5.14.2** When a reserve is provided inside the building as a substitute for the EOSC or for other purposes, it shall be located in accordance with 5.1.3.3 as follows:

- (1) In a room or enclosure constructed per 5.1.3.3.2
- (2) In a room or enclosure ventilated per 5.1.3.3.3

**5.1.3.5.14.3** In-building emergency reserves shall consist of either of the following:

- (1) Gas cylinder header per 5.1.3.5.9 with sufficient cylinder connections to provide for at least an average day's supply with the appropriate number of connections being determined after consideration of the delivery schedule, the proximity of the facility to alternate supplies, and the facility's emergency plan
- (2) Manifold for gas cylinders complying with 5.1.3.5.10

**5.1.3.5.14.4** In-building emergency reserves shall include a check valve in the main line placed on the distribution system side of the ordinary source's main line valve to prevent flow of gas from the emergency reserve to the ordinary source.

**5.1.3.5.14.5** In-building emergency reserves shall have a local signal that visibly indicates the operating status of the equipment and an alarm at all master alarms when or just before the reserve begins to serve the system.

**5.1.3.6\* Category 1 Medical Air Supply Systems.**

**5.1.3.6.1\* Quality of Medical Air.** Medical air shall be required to have the following characteristics:

- (1) It shall be supplied from cylinders, bulk containers, or medical air compressor sources, or it shall be reconstituted from oxygen USP and oil-free, dry nitrogen NF.
- (2) It shall meet the requirements of medical air USP.
- (3) It shall have no detectable liquid hydrocarbons.
- (4) It shall have less than 25 ppm gaseous hydrocarbons.
- (5) It shall have equal to or less than 1 mg/m<sup>3</sup> (6.85 × 10<sup>-7</sup> lb/yd<sup>3</sup>) of permanent particulates sized 1 micron or larger in the air at normal atmospheric pressure.

**5.1.3.6.2\* Uses of Medical Air.** Medical air sources shall be connected to the medical air distribution system only and shall be used only for air in the application of human respiration and calibration of medical devices for respiratory application.

**5.1.3.6.3\* Medical Air Compressor Sources.**

**5.1.3.6.3.1 Location.** Medical air compressor systems shall be located per 5.1.3.3 as follows:

- (1) Indoors in a dedicated mechanical equipment area, adequately ventilated and with any required utilities (e.g., electricity, drains, lighting)
- (2) In a room ventilated per 5.1.3.3.3.2
- (3) For air-cooled equipment, in a room designed to maintain the ambient temperature range as recommended by the manufacturer

**5.1.3.6.3.2 Required Components.** Medical air compressor systems shall consist of the following:

- (1) Components complying with 5.1.3.6.3.4 through 5.1.3.6.3.9, arranged per 5.1.3.6.3.10
- (2) Automatic means to prevent backflow from all on-cycle compressors through all off-cycle compressors
- (3) Manual shutoff valve to isolate each compressor from the centrally piped system and from other compressors for maintenance or repair without loss of pressure in the system
- (4) Intake filter-muffler(s) of the dry type
- (5) Pressure relief valve(s) set at 50 percent above line pressure
- (6) Piping and components between the compressor and the source shutoff valve that do not contribute to contaminant levels
- (7) Except as defined in 5.1.3.6.3.2(1) through (6), materials and devices used between the medical air intake and the medical air source valve that are of any design or construction appropriate for the service as determined by the manufacturer

**5.1.3.6.3.3 Air Drying Equipment.** Medical air compressor systems shall preclude the condensation of water vapor in the piping distribution system by the selection of the air drying equipment.

**5.1.3.6.3.4 Compressors for Medical Air.**

**(A)\*** Compressors for medical air shall be designed to prevent the introduction of contaminants or liquid into the pipeline by any of the following methods:

- (1) Elimination of oil anywhere in the compressor (e.g., liquid ring and permanently sealed bearing compressors)
- (2) Reciprocating compressors provided with a separation of the oil-containing section from the compression chamber by at least two seals creating an area open to atmosphere that allows the following:

- (a) Direct and unobstructed visual inspection of the interconnecting shaft through vent and inspection openings no smaller than 1.5 shaft diameters in size
  - (b) Confirmation by the facility operators of proper seal operation by direct visual inspection through the above-shaft opening, without disassembly of the compressor (e.g., extended head compressors with an atmospheric vent between the compression chamber and the crankcase)
- (3) Rotating element compressors provided with a compression chamber free of oil that provide the following:
- (a) Separation of each oil-containing section from the compression chamber by at least one seal having atmospheric vents on each side with the vent closest to the oil-containing section supplied with a gravity drain to atmosphere
  - (b) Unobstructed visualization of the atmospheric vent(s), closest to each oil-containing section, that is accessible for inspection without disassembling the compressor
  - (c) Entry of the rotating shaft into each compression chamber at a point that is above atmospheric pressure
  - (d) Confirmation by the facility operators of proper seal operation by direct visual inspection of the atmospheric vents

**(B)** For liquid ring compressors, service water and seal water shall be treated to control waterborne pathogens and chlorine from hyperchlorination from entering the medical air.

**(C)** Liquid ring compressors shall comply with the following:

- (1) Service water and seal water of a quality recommended by the compressor manufacturer shall be used.
- (2) Reserve medical air standby headers or a backup compressor shall be installed.
- (3) When installed, the header shall comply with 5.1.3.5.9.
- (4) When installed, the number of attached cylinders shall be sufficient for 1 hour normal operation.

**(D)** Compressors shall be constructed of materials deemed suitable by the manufacturer.

**(E)** Antivibration mountings shall be installed for compressors as required by equipment dynamics or location and in accordance with the manufacturer's recommendations.

**(F)** Flexible connectors shall connect the air compressors with their intake and outlet piping.

**5.1.3.6.3.5 Aftercoolers.**

**(A)** Aftercoolers, where required, shall be provided with individual condensate traps.

**(B)** The receiver shall not be used as an aftercooler or aftercooler trap.

**(C)** Aftercoolers shall be constructed of materials deemed suitable by the manufacturer.

**(D)** Antivibration mountings shall be installed for aftercoolers as required by equipment dynamics or location and in accordance with the manufacturer's recommendations.

**5.1.3.6.3.6 Medical Air Receivers.** Receivers for medical air shall meet the following requirements:

- (1) They shall be made of corrosion-resistant materials or otherwise be made corrosion resistant.
- (2) They shall comply with Section VIII, "Unfired Pressure Vessels," of the ASME *Boiler and Pressure Vessel Code*.

- (3) They shall be equipped with a pressure relief valve, automatic drain, manual drain, sight glass, and pressure indicator.
- (4) They shall be of a capacity sufficient to prevent the compressors from short-cycling.

**5.1.3.6.3.7 Medical Air Dryers.** Medical air dryers shall meet the following requirements:

- (1) They shall be designed to provide air at a maximum dew point that is below the frost point [ $0^{\circ}\text{C}$  ( $32^{\circ}\text{F}$ )] at 345 kPa to 380 kPa (50 psi to 55 psi) at any level of demand.
- (2) They shall be sized for 100 percent of the system peak calculated demand at design conditions.
- (3) They shall be constructed of materials deemed suitable by the manufacturer.
- (4) They shall be provided with antivibration mountings installed as required by equipment dynamics or location and in accordance with the manufacturer's recommendations.

**5.1.3.6.3.8 Medical Air Filters.** Medical air filters shall meet the following requirements:

- (1) They shall be appropriate for the intake air conditions.
- (2) They shall be located upstream (source side) of the final line regulators.
- (3) They shall be sized for 100 percent of the system peak calculated demand at design conditions and be rated for a minimum of 98 percent efficiency at 1 micron or greater.
- (4) They shall be equipped with a continuous visual indicator showing the status of the filter element life.
- (5) They shall be constructed of materials deemed suitable by the manufacturer.

**5.1.3.6.3.9\* Medical Air Local Alarm.** A local alarm complying with 5.1.9.5 shall be provided for the medical air compressor source.

**5.1.3.6.3.10 Piping Arrangement and Redundancies.**

- (A) Component arrangement shall be as follows:
- (1) Components shall be arranged to allow service and a continuous supply of medical air in the event of a single fault failure.
  - (2) Component arrangement shall be permitted to vary as required by the technology(ies) employed, provided that an equal level of operating redundancy and medical air quality is maintained.
- (B) Medical air compressors shall be sufficient to serve the peak calculated demand with the largest single compressor out of service. In no case shall there be fewer than two compressors.
- (C) When aftercoolers are provided, they shall be arranged to meet either one of the following:
- (1) Arranged as a duplex or multiplex set, sized to serve the peak calculated demand with the largest single aftercooler out of service, and provided with valves adequate, to isolate any single aftercooler from the system without shutting down supply of medical air
  - (2) Arranged one per compressor, sized to handle the output of that compressor, and valved as appropriate to allow repair or replacement with that compressor out of service but without shutting down supply of medical air

(D)\* A medical air receiver(s) shall be provided with proper valves to allow the flow of compressed air to enter and exit out of separate receiver ports during normal operation and allow the receiver to be bypassed during service without shutting down the supply of medical air.

(E) Dryers, filters, and regulators shall be at least duplexed, with each component sized to serve the peak calculated demand with the largest of each component out of service.

(F)\* Dryers, filters, and regulators shall be provided with manual valves upstream and manual valves or check valves downstream to allow service to the components without shutting down the system in either one of the following ways:

- (1) They shall be installed for each component, upstream and downstream of each component, allowing each to be individually isolated.
- (2) They shall be installed upstream (source side) and downstream of components in series so as to create redundant parallel branches of components.

(G) A three-way valve (three-port), indexed to flow, full port shall be permitted to be used to isolate one branch or component for the purposes of 5.1.3.6.3.10(C), 5.1.3.6.3.10(D), 5.1.3.6.3.10(E), and 5.1.3.6.3.10(F).

(H) Under normal operation, only one aftercooler shall be open to airflow with the other aftercooler valved off.

(I) Under normal operation, only one dryer-filter(s)-regulator sequence shall be open to airflow with the other sequence valved off.

(J) If the relief valve required in 5.1.3.6.3.2(5) and 5.1.3.6.3.6(3) can be isolated from the system by the valve arrangement used to comply with 5.1.3.6.3.10(F), then a redundant relief valve(s) shall be installed in the parallel sequence.

(K) A DN8 (NPS  $\frac{1}{4}$ ) valved sample port shall be provided downstream of the final line pressure regulators, dew point monitor, and carbon monoxide monitor and upstream of the source shutoff valve to allow for sampling of the medical air.

(L) Medical air source systems shall be provided with a source valve per 5.1.4.4.

(M) Where medical air piping systems at different operating pressures are required, the piping shall separate after the filters but shall be provided with separate line regulators, dew point monitors, relief valves, and source shutoff valves.

**5.1.3.6.3.11 Electrical Power and Control.**

(A) An additional compressor(s) shall automatically activate when the compressor(s) in operation is incapable of maintaining the required pressure.

(B) Automatic or manual alternation of compressors shall allow division of operating time. If automatic alternation of compressors is not provided, the facility staff shall arrange a schedule for manual alternation.

(C) Each compressor motor shall be provided with electrical components including, but not limited to, the following:

- (1) Dedicated disconnect switch installed in the electrical circuit ahead of each motor starter
- (2) Motor starting device
- (3) Overload protection

- (4) Where compressor systems having two or more compressors employ a control transformer or other voltage control power device, installation of at least two such devices.
  - (5) Control circuits arranged in such a manner that the shut-down of one compressor does not interrupt the operation of another compressor
  - (6) Automatic restart function, such that the compressor(s) will restart after power interruption without manual intervention
- (D) Electrical installation and wiring shall conform to the requirements of *NFPA 70, National Electrical Code*.
- (E) Emergency electrical service for the compressors shall conform to the requirements of the essential electrical system as described in Chapter 6.

**5.1.3.6.3.12 Compressor Intake.**

- (A) The medical air compressors shall draw their air from a source of clean air.
- (B) The medical air intake shall be located a minimum of 7.6 m (25 ft) from ventilating system exhausts, fuel storage vents, combustion vents, plumbing vents, vacuum and WAGD discharges, or areas that can collect vehicular exhausts or other noxious fumes.
- (C) The medical air intake shall be located a minimum of 6 m (20 ft) above ground level.
- (D) The medical air intake shall be located a minimum of 3.0 m (10 ft) from any door, window, or other opening in the building.
- (E) If an air source equal to or better than outside air (e.g., air already filtered for use in operating room ventilating systems) is available, it shall be permitted to be used for the medical air compressors with the following provisions:
- (1) This alternate source of supply air shall be available on a continuous 24-hour-per-day, 7-day-per-week basis.
  - (2) Ventilating systems having fans with motors or drive belts located in the airstream shall not be used as a source of medical air intake.
- (F) Compressor intake piping shall be permitted to be made of materials and use a jointing technique as permitted under 5.1.10.2.
- (G) Air intakes for separate compressors shall be permitted to be joined together to one common intake where the following conditions are met:

- (1) The common intake is sized to minimize back pressure in accordance with the manufacturer's recommendations.
  - (2) Each compressor can be isolated by manual or check valve, blind flange, or tube cap to prevent open inlet piping when the compressor(s) is removed for service from the consequent backflow of room air into the other compressor(s).
- (H) The end of the intake shall be turned down and screened or otherwise be protected against the entry of vermin, debris, or precipitation by screening fabricated or composed of a noncorroding material.

**5.1.3.6.3.13 Operating Alarms and Local Signals.** Medical air systems shall be monitored for conditions that can affect air quality during use or in the event of failure, based on the type of compressor(s) used in the system.

(A) Where liquid ring air compressors, compressors having water-cooled heads, or water-cooled aftercoolers are used, air

receivers shall be equipped with a high water level sensor that shuts down the compressor system and activates a local alarm indicator. [See 5.1.9.5.4(7).]

(B) Where liquid ring compressors are used, each compressor shall have a liquid level sensor in each air-water separator that, when the liquid level is above the design level, shuts down its compressor and activates a local alarm indicator. [See 5.1.9.5.4(8).]

(C) Where nonliquid ring compressors compliant with 5.1.3.6.3.4(A)(1) are used, the air temperature at the immediate outlet of each compressor cylinder shall be monitored by a high-temperature sensor that shuts down that compressor and activates a local alarm indicator [see 5.1.9.5.4(9)]. The temperature setting shall be as recommended by the compressor manufacturer.

(D) Where compressors compliant with 5.1.3.6.3.4(A)(2) and (3) are used, the following requirements shall apply:

- (1) The air temperature at the immediate outlet of each compressor chamber shall be monitored by a high-temperature sensor that shuts down that compressor and activates a local alarm indicator [see 5.1.9.5.4], the temperature setting shall be as recommended by the compressor manufacturer.
- (2) Coalescing filters with element change indicator shall be provided.
- (3) Charcoal absorber shall be provided.
- (4) Gaseous hydrocarbons shall be monitored on a quarterly basis.

(E) When the backup or lag compressor is running, a local alarm shall activate [see 5.1.9.5.4(1)]. This signal shall be manually reset.

**5.1.3.6.3.14 Medical Air Quality Monitoring.** Medical air quality shall be monitored downstream of the medical air regulators and upstream of the piping system as follows:

- (1) Dew point shall be monitored and shall activate a local alarm and all master alarms when the dew point at system delivery pressure exceeds +2°C (+35°F).
- (2) Carbon monoxide shall be monitored and shall activate a local alarm when the CO level exceeds 10 ppm. [See 5.1.9.5.4(2).]
- (3) Dew point and carbon monoxide monitors shall activate their individual monitor's signal at the alarm panels where their signals are required when their power is lost.

**5.1.3.6.3.15 Category 1 Medical Air Proportioning System.**

(A) **General.**

- (1) Medical air reconstituted from oxygen USP and nitrogen NF, produced using proportioning system(s), shall be required to meet the following:
  - (a) The quality of medical air shall be in accordance with 5.1.3.6.1.
  - (b) The system shall be capable of supplying this quality of medical air, per 5.1.3.5.1, over the entire range of flow.
  - (c) The system shall produce medical air with an oxygen content of 19.5 percent to 23.5 percent.
  - (d) The medical air shall be cleared for marketing by the FDA or approved by the FDA.
- (2) The medical air proportioning system shall operate automatically.
- (3) The mixture shall be analyzed continuously, and a recording capability shall be provided (e.g., via data port).

- (4) The analyzing system specified in 5.1.3.6.3.15(A)(3) shall be a dedicated and an independent analyzer used to control the medical air proportioning system.
- (5) If the mixture goes out of specification, an alarm shall be activated automatically, the primary medical air proportioning system shall be disconnected, and the reserve supply shall be activated.
- (6) The system shall be arranged such that manual intervention is necessary to correct the composition of the mixture before reconnecting the medical air proportioning system to the health care facility pipeline system.
- (7) If dedicated sources of oxygen USP and nitrogen NF supply the medical air proportioning system, reserve sources for the oxygen and nitrogen shall not be required.
- (8) If dedicated sources of oxygen USP and nitrogen NF supply the medical air proportioning system, they shall not be used as the reserves for oxygen and nitrogen systems supplying the pipelines of the health care facility.
- (9)\*If the sources of oxygen USP and nitrogen NF that supply the medical air proportioning system are the same sources that supply the health care facility, engineering controls shall be provided to prevent cross contamination of oxygen and nitrogen supply lines, as provided in 5.1.3.5.7.
- (10) A risk analysis and approval from the authority having jurisdiction shall be required.

**(B) Location.** The medical air proportioning system shall be located per 5.1.3.3 as follows:

- (1) The medical air proportioning system's supply of oxygen USP and nitrogen NF shall be located per 5.1.3.3 and NFPA 55, as applicable.
- (2) The mixing device and controls, analyzers, and receivers shall be located indoors within a room or area per 5.1.3.3.1.
- (3) The indoor location shall include atmospheric monitoring for oxygen concentration.
- (4) The indoor location shall be constructed with all required utilities (e.g., electricity, drains, lighting) per *NFPA 5000*.
- (5) The indoor location shall be ventilated and heated per Chapter 9 and the manufacturer's recommendations.

**(C) Required Components.** The medical air proportioning system shall consist of the following:

- (1) Supply of oxygen USP and supply of nitrogen NF as follows:
  - (a) The supply lines shall be filtered to remove particulate entering the proportioning system.
  - (b) The minimum safe supply gas temperature and recommended local signal shall be specified by the medical air proportioning system manufacturer.
- (2) Mixing device with analyzers and engineering controls per manufacturer's recommendations to include, as a minimum, the following:
  - (a) At least two oxygen analyzers capable of independently monitoring oxygen concentration
  - (b) Mechanism where each analyzer based upon nonconforming oxygen concentration is capable, directly or via other medical air proportioning system controls, of automatically shutting off the supply from the medical air proportioning system to the medical air piped distribution system and activating the reserve supply
  - (c) Mechanism where each analyzer, based upon nonconforming oxygen concentration, is capable, directly or via other proportioning system controls, of automatically shutting off the supply of oxygen and

nitrogen to the proportioning system and activating the reserve supply

- (d) Provision for manual resetting of the proportioning system after detection of nonconforming oxygen concentration and subsequent shutdown once conforming oxygen concentration is established, in order to re-establish flow to the medical air piping system
  - (e) Means of verifying the performance of the analyzers by reference to an air standard, with known traceable oxygen content
- (3) Minimum of one recorder for recording the medical air proportioning system performance and air quality for a period of not less than 24 hours
  - (4) Continuous analysis of the mixture and a recording capability provided (e.g., via a data port)
  - (5) Mechanism for isolating the primary medical air proportioning system from the reserve supply and the medical air piping distribution system by employing sequential valves for redundancy
  - (6) Capability of the reserve supply to automatically activate if the primary supply is isolated
  - (7) Reserve supply of medical air USP sized, at minimum, for an average day's supply and consisting of one of the following:
    - (a) Additional medical air proportioning unit with a dedicated supply of oxygen USP and nitrogen NF
    - (b) Medical air compressor system per 5.1.3.5.10, with the exception of the allowance of a simplex medical air compressor system
    - (c) Medical air cylinder manifold per 5.1.3.5.10
  - (8) Receiver fitted with a pressure relief valve and pressure gauge as follows:
    - (a) The receiver shall be constructed of corrosion-resistant materials.
    - (b) The receiver, relief valves, and pressure gauges shall comply with ASME *Boiler and Vessel Code* and manufacturer's recommendations.
  - (9)\*Warning systems per 5.1.9, including a local signal and master alarm that indicates nonconforming oxygen concentration per manufacturer's recommendations
  - (10) Final line pressure regulators complying with 5.1.3.5.5
  - (11) Pressure relief complying with 5.1.3.5.6
  - (12) Local signals complying with 5.1.3.5.8.2

### 5.1.3.7\* Medical-Surgical Vacuum Supply Systems.

#### 5.1.3.7.1 Medical-Surgical Vacuum Sources.

5.1.3.7.1.1 Medical-surgical vacuum sources shall be located per 5.1.3.3 as follows:

- (1) Indoors in a dedicated mechanical equipment area, adequately ventilated and with any required utilities
- (2) In a room ventilated per 5.1.3.3.3.2
- (3) For air-cooled equipment, in a room designed to maintain the ambient temperature range as recommended by the equipment manufacturer

5.1.3.7.1.2 Medical-surgical vacuum sources shall consist of the following:

- (1) Two or more vacuum pumps sufficient to serve the peak calculated demand with the largest single vacuum pump out of service
- (2) Automatic means to prevent backflow from any on-cycle vacuum pumps through any off-cycle vacuum pumps



- (3) Shutoff valve or other isolation means to isolate each vacuum pump from the centrally piped system and other vacuum pumps for maintenance or repair without loss of vacuum in the system
- (4) Vacuum receiver
- (5) Piping between the vacuum pump(s), discharge(s), receiver(s), and vacuum source shutoff valve in accordance with 5.1.10.2, except brass, galvanized, or black steel pipe, which is permitted to be used as recommended by the manufacturer
- (6) Except as defined in 5.1.3.7.1.2(1) through (5), materials and devices used between the medical vacuum exhaust and the medical vacuum source that are permitted to be of any design or construction appropriate for the service as determined by the manufacturer

#### 5.1.3.7.2 Vacuum Pumps.

**5.1.3.7.2.1** Vacuum pumps shall be constructed of materials deemed suitable by the manufacturer.

**5.1.3.7.2.2** Antivibration mountings shall be installed for vacuum pumps as required by equipment dynamics or location and in accordance with the manufacturer's recommendations.

**5.1.3.7.2.3** Flexible connectors shall connect the vacuum pumps with their intake and outlet piping.

**5.1.3.7.2.4** For liquid ring vacuum pumps, seal water shall be of a quality recommended by the vacuum pump manufacturer.

**5.1.3.7.3 Vacuum Receivers.** Receivers for vacuum shall meet the following requirements:

- (1) They shall be made of materials deemed suitable by the manufacturer.
- (2) They shall comply with Section VIII, "Unfired Pressure Vessels," of the ASME *Boiler and Pressure Vessel Code*.
- (3) They shall be capable of withstanding a gauge pressure of 415 kPa (60 psi) and 760 mm (30 in.) gauge HgV.
- (4) They shall be equipped with a manual drain.
- (5) They shall be of a capacity based on the technology of the pumps.

**5.1.3.7.4 Vacuum Local Alarm.** A local alarm complying with 5.1.9.5 shall be provided for the vacuum source.

#### 5.1.3.7.5 Piping Arrangement and Redundancies.

**5.1.3.7.5.1** Piping arrangement shall be as follows:

- (1) Piping shall be arranged to allow service and a continuous supply of medical-surgical vacuum in the event of a single fault failure.
- (2) Piping arrangement shall be permitted to vary based on the technology(ies) employed, provided that an equal level of operating redundancy is maintained.
- (3) Where only one set of vacuum pumps is available for a combined medical-surgical vacuum system and an analysis, a research, or a teaching laboratory vacuum system, such laboratories shall be connected separately from the medical-surgical system directly to the receiver tank through its own isolation valve and fluid trap located at the receiver, and between the isolation valve and fluid trap, a scrubber shall be permitted to be installed.

**5.1.3.7.5.2** The medical-surgical vacuum receiver(s) shall be serviceable without shutting down the medical-surgical vacuum system by any method to ensure continuation of service to the facility's medical-surgical pipeline distribution system.

**5.1.3.7.5.3** Medical-surgical vacuum source systems shall be provided with a source shutoff valve per 5.1.4.4.

#### 5.1.3.7.6 Electrical Power and Control.

**5.1.3.7.6.1** Additional pumps shall automatically activate when the pump(s) in operation is incapable of adequately maintaining the required vacuum.

**5.1.3.7.6.2** Automatic or manual alternation of pumps shall allow division of operating time. If automatic alternation of pumps is not provided, the facility staff shall arrange a schedule for manual alternation.

**5.1.3.7.6.3** Each pump motor shall be provided with electrical components including, but not limited to, the following:

- (1) Dedicated disconnect switch installed in the electrical circuit ahead of each motor starter
- (2) Motor starting device
- (3) Overload protection
- (4) Where pump systems having two or more pumps employ a control transformer or other voltage control power device, at least two such devices
- (5) Control circuits arranged in such a manner that the shutdown of one pump does not interrupt the operation of another pump
- (6) Automatic restart function such that the pump(s) will restart after power interruption without manual intervention

**5.1.3.7.6.4** Electrical installation and wiring shall conform to the requirements of *NFPA 70, National Electrical Code*.

**5.1.3.7.6.5** Emergency electrical service for the pumps shall conform to the requirements of the essential electrical system as described in Chapter 6.

#### 5.1.3.7.7 Medical-Surgical Vacuum Source Exhaust.

**5.1.3.7.7.1** The medical-surgical vacuum pumps shall exhaust in a manner and location that minimizes the hazards of noise and contamination to the facility and its environment.

**5.1.3.7.7.2** The exhaust shall be located as follows:

- (1) Outdoors
- (2) At least 3.05 m (10 ft) from any door, window, air intake, or other openings in buildings or places of public assembly
- (3) At a level different from air intakes
- (4) Where prevailing winds, adjacent buildings, topography, or other influences will not divert the exhaust into occupied areas or prevent dispersion of the exhaust

**5.1.3.7.7.3** The end of the exhaust shall be turned down and screened or otherwise be protected against the entry of vermin, debris, or precipitation by screening fabricated or composed of a noncorroding material.

**5.1.3.7.7.4** The exhaust shall be free of dips and loops that might trap condensate or oil or provided with a drip leg and valved drain at the bottom of the low point.

**5.1.3.7.7.5** Vacuum exhausts from multiple pumps shall be permitted to be joined together to one common exhaust where the following conditions are met:

- (1) The common exhaust is sized to minimize back pressure in accordance with the pump manufacturer's recommendations.
- (2) Each pump can be isolated by manual or check valve, blind flange, or tube cap to prevent open exhaust piping when the pump(s) is removed for service from consequent flow of exhaust air into the room.

**5.1.3.7.8 Operating Alarms.** Medical-surgical vacuum systems shall activate a local alarm when the backup or lag pump is running per 5.1.9.5. This signal shall be manually reset.

**5.1.3.8\* Waste Anesthetic Gas Disposal (WAGD).**

**5.1.3.8.1\* Sources.** WAGD sources shall be chosen in consultation with the medical staff having knowledge of the requirements to determine the type of system, number and placement of terminals, and other required safety and operating devices.

**5.1.3.8.1.1** WAGD shall be permitted to be produced through the medical-surgical vacuum source, by a dedicated producer, or by venturi.

**5.1.3.8.1.2** If WAGD is produced by the medical-surgical vacuum source, the following shall apply:

- (1) The medical-surgical vacuum source shall comply with 5.1.3.7.
- (2) The total concentration of oxidizers (oxygen and nitrous oxide) shall be maintained below 23.6 percent, or the vacuum pump shall comply with 5.1.3.8.2.1.
- (3) The medical-surgical vacuum source shall be sized to accommodate the additional volume.

**5.1.3.8.1.3** If WAGD is produced by a dedicated WAGD producer with a total power equal to or greater than 1 horsepower in total (both producers), the following shall apply:

- (1) The WAGD source shall be located in accordance with 5.1.3.3.
- (2) The WAGD source shall be located indoors in a dedicated mechanical equipment area with any required utilities.
- (3) The WAGD source shall be ventilated per 5.1.3.3.3.2.
- (4) For air-cooled equipment, the WAGD source shall be located to maintain the ambient temperature range as recommended by the manufacturer.
- (5) The WAGD producers shall comply with 5.1.3.8.2.

**5.1.3.8.1.4** If WAGD is produced by a dedicated WAGD producer with a total power less than 1 horsepower in total (both producers), the following shall apply:

- (1) The WAGD source shall be permitted to be located near the inlet(s) served.
- (2) For air-cooled equipment, the WAGD source shall be located to maintain the ambient temperature range as recommended by the manufacturer.

**5.1.3.8.1.5** For liquid ring pumps in WAGD service, seal water shall be of a quality as recommended by the pump manufacturer.

**5.1.3.8.1.6** The WAGD source shall consist of the following:

- (1) Two or more WAGD producers sufficient to serve the peak calculated demand with the largest single WAGD producer out of service
- (2) Automatic means to prevent backflow from any on-cycle WAGD producers through any off-cycle WAGD producers
- (3) Shutoff valve to isolate each WAGD producer from the centrally piped system and other WAGD producers for maintenance or repair without loss of medical-surgical vacuum in the system
- (4) Piping between the WAGD producers and the source shutoff valve compliant with 5.1.10.2, as recommended by the manufacturer
- (5) Antivibration mountings installed for WAGD producers as required by equipment dynamics or location and in accordance with the manufacturer's recommendations

- (6) Flexible connectors interconnecting the producers with their intake and outlet piping as required by equipment dynamics or location and in accordance with the WAGD producer manufacturer's recommendations

**5.1.3.8.1.7** If WAGD is produced by a venturi, the following shall apply:

- (1) The venturi shall not be user-adjustable (i.e., require the use of special tools).
- (2) The venturi shall be driven using water, inert gas, instrument air, or other dedicated air source.
- (3) Medical air shall not be used to power the venturi.

**5.1.3.8.2 WAGD Producers.**

**5.1.3.8.2.1** Vacuum pumps dedicated for WAGD service shall be as follows:

- (1) Compliant with 5.1.3.7.2
- (2) Designed of materials and using lubricants and sealants that are inert in the presence of oxygen, nitrous oxide, and halogenated anesthetics

**5.1.3.8.2.2** Vacuum producers (e.g., fans or blowers) designed for operation at vacuums below 130 mm (5 in.) HgV shall be as follows:

- (1) Permitted to be made of any materials determined by the manufacturer as suitable for the service
- (2) Provided with antivibration mountings as required by equipment dynamics or location and in accordance with the manufacturer's recommendation
- (3) Connected with their intake and outlet piping through flexible connections
- (4) Used only for WAGD service and not employed for other services
- (5) Interconnected via piping, ductwork, and so forth, made of materials determined by the manufacturer as suitable to the service

**5.1.3.8.3 WAGD Connections to Vacuum Piping.** If WAGD is joined to vacuum piping, it shall be connected at a minimum distance of 1.5 m (5 ft) from any vacuum inlet.

**5.1.3.8.4 WAGD Alarms.**

**5.1.3.8.4.1** When the WAGD system is served by a central source(s), a local alarm complying with 5.1.9.5 shall be provided for the WAGD source.

**5.1.3.8.4.2** A WAGD source system shall activate a local alarm when the backup or lag producer is running.

**5.1.3.8.5 Electrical Power and Control.**

**5.1.3.8.5.1** Additional producers shall automatically activate when the producer(s) in operation is incapable of maintaining the required vacuum.

**5.1.3.8.5.2** Automatic or manual alternation of producers shall allow division of operating time. If automatic alternation of producers is not provided, the facility staff shall arrange a schedule for manual alternation.

**5.1.3.8.5.3** Each producer motor shall be provided with electrical components including, but not limited to, the following:

- (1) Dedicated disconnect switch installed in the electrical circuit ahead of each motor starter
- (2) Motor starting device
- (3) Overload protection

- (4) Where WAGD systems having two or more producers employ a control transformer or other voltage control power device, at least two such devices
- (5) Control circuits arranged in such a manner that the shut-down of one producer does not interrupt the operation of another producer
- (6) Automatic restart function such that the pump(s) will restart after power interruption without manual intervention

**5.1.3.8.5.4** Electrical installation and wiring shall conform to the requirements of *NFPA 70, National Electrical Code*.

**5.1.3.8.5.5** Emergency electrical service for the producers shall conform to the requirements of the essential electrical system as described in Chapter 6.

**5.1.3.8.6 WAGD Exhaust.** The WAGD pumps shall exhaust in compliance with 5.1.3.7.7.

#### **5.1.3.9\* Instrument Air Supply Systems.**

**5.1.3.9.1 Quality of Instrument Air.** The quality of instrument air shall be as follows:

- (1) Compliant with instrument air section in ANSI/ISA S-7.0.01, *Quality Standard for Instrument Air*
- (2) Filtered to 0.01 micron
- (3) Free of liquids (e.g., water, hydrocarbons, solvents)
- (4) Free of hydrocarbon vapors
- (5) Dry to a dew point of  $-40^{\circ}\text{C}$  ( $-40^{\circ}\text{F}$ )

#### **5.1.3.9.2 General.**

**5.1.3.9.2.1** Instrument air shall be permitted to be used for any medical support purpose (e.g., to remove excess moisture from instruments before further processing, or to operate medical-surgical tools, air-driven booms, pendants, or similar applications) and, if appropriate to the procedures, to be used in laboratories.

**5.1.3.9.2.2** Instrument air supply systems shall be located per 5.1.3.3 as follows:

- (1) Indoors, in a dedicated mechanical equipment area that is adequately ventilated and with any required utilities
- (2) In a room ventilated per 5.1.3.3.3.2
- (3) For air-cooled equipment, in a room designed to maintain the ambient temperature range as recommended by the equipment manufacturer

**5.1.3.9.2.3** Instrument air systems shall be prohibited from the following:

- (1) Interconnection with medical air systems
- (2) Usage for any purpose where the air will be intentionally respired by patients or staff

#### **5.1.3.9.3 Instrument Air Source.**

**5.1.3.9.3.1** Instrument air sources shall produce air at not less than a gauge pressure of 1380 kPa (200 psi) output pressure.

**5.1.3.9.3.2** Instrument air sources shall provide air meeting the definition of instrument air in Chapter 3.

**5.1.3.9.3.3** Instrument air sources shall be permitted to include at least two compressors or one compressor and a standby header complying with 5.1.3.5.8.

**5.1.3.9.3.4** Instrument air sources shall comply with 5.1.3.6.3, with exceptions as specified in 5.1.3.9.

**5.1.3.9.4 Instrument Air Compressors.** Instrument air compressors shall be permitted to be of any type capable of not less

than a gauge pressure of 1380 kPa (200 psi) output pressure and of providing air meeting the definition of *instrument air* in Chapter 3.

**5.1.3.9.5 Instrument Air Standby Headers.** Where instrument air systems are provided with a standby header, the header shall meet the following requirements:

- (1) It shall comply with 5.1.3.5.9, except that the number of attached cylinders shall be sufficient for 1 hour normal operation.
- (2) It shall use connectors as for medical air in CGA V-1, *Compressed Gas Association Standard for Compressed Gas Cylinder Valve Outlet and Inlet Connections* (ANSI B57.1).
- (3) It shall enter the system upstream (source side) of the final line filters. (See *Figure A.5.1.3.9*.)
- (4) It shall automatically serve the system in the event of a failure of the compressor.

**5.1.3.9.6\* Intake Air.** Intake air for instrument air compressors shall be permitted to be drawn from the outside, from ducted air, or from the equipment location.

#### **5.1.3.9.7 Instrument Air Filters.**

**5.1.3.9.7.1** Instrument air sources shall be filtered with activated carbon filters that meet the following requirements:

- (1) They shall be located upstream (source side) of the final line filters.
- (2) They shall be sized for 100 percent of the system peak calculated demand at design conditions.
- (3) They shall be constructed of materials deemed suitable by the manufacturer.

**5.1.3.9.7.2** Final line filters shall meet the following requirements:

- (1) They shall be located upstream (source side) of the final line regulators and downstream of the carbon filters
- (2) They shall be sized for 100 percent of the system peak calculated demand at design conditions.
- (3) They shall be rated for a minimum of 98 percent efficiency at 0.01 micron.
- (4) They shall be equipped with a continuous visual indicator showing the status of the filter element life.
- (5) They shall be constructed of materials deemed suitable by the manufacturer.

**5.1.3.9.7.3** Filters combining the function of 5.1.3.9.7.1 and 5.1.3.9.7.2 shall be permitted to be used.

**5.1.3.9.8 Instrument Air Accessories.** Accessories used for instrument air sources shall comply with the following subparagraphs:

- (1) 5.1.3.6.3.5 for aftercoolers
- (2) 5.1.3.6.3.6 for air receivers
- (3) 5.1.3.6.3.7 for air dryers
- (4) 5.1.3.5.9 for air regulators

**5.1.3.9.9 Instrument Air Piping Arrangement and Redundancies.** Instrument air sources shall comply with 5.1.3.6.3.10, except for the following:

- (1) Systems employing a standby header shall be permitted to have simplex aftercoolers and dryers.
- (2) Systems employing a standby header shall not require a three-valve receiver bypass.
- (3) Standby headers, where provided, shall be isolated from the compressor by a check valve to prevent backflow through the compressor.



### 5.1.3.9.10 Instrument Air Monitoring and Alarms.

5.1.3.9.10.1 Instrument air sources shall include the following alarms:

- (1) Local alarm that activates when or just before the backup compressor (if provided) activates, indicating that the lag compressor is in operation and that must be manually reset
- (2) Local alarm and alarms at all master alarm panels that activate when the dew point at system pressure exceeds  $-30^{\circ}\text{C}$  ( $-22^{\circ}\text{F}$ ), indicating high dew point

5.1.3.9.10.2 For sources with standby headers, the following additional conditions shall activate a local alarm at the compressor site, a local signal at the header location, and alarms at all master alarm panels:

- (1) Alarm that activates when or just before the reserve begins to supply the system, indicating reserve in use
- (2) Alarm that activates when or just before the reserve falls below an average hour's supply, indicating reserve low

### 5.1.3.9.11 Electrical Power and Control.

5.1.3.9.11.1 When multiple compressors are used, an additional compressor(s) shall automatically activate when the compressor(s) in operation is incapable of maintaining the required pressure.

5.1.3.9.11.2 When multiple compressors are used, automatic or manual alternation of compressors shall allow division of operating time. If automatic alternation of compressors is not provided, the facility staff shall arrange a schedule for manual alternation.

5.1.3.9.11.3 Each compressor motor shall be provided with electrical components including, but not limited to, the following:

- (1) Dedicated disconnect switch installed in the electrical circuit ahead of each motor starter
- (2) Motor starting device
- (3) Overload protection
- (4) Where compressor systems having two or more compressors employ a control transformer or other voltage control power device, installation of at least two such devices
- (5) Control circuits arranged in such a manner that the shutdown of one compressor does not interrupt the operation of another compressor
- (6) Automatic restart function such that the compressor(s) will restart after power interruption without manual intervention

5.1.3.9.11.4 Electrical installation and wiring shall conform to the requirements of *NFPA 70, National Electrical Code*.

5.1.3.9.11.5 Emergency electrical service for the compressors shall conform to the requirements of the essential electrical system as described in Chapter 6.

### 5.1.4\* Valves.

5.1.4.1 **Gas and Vacuum Shutoff Valves.** Shutoff valves shall be provided to isolate sections or portions of the piped distribution system for maintenance, repair, or planned future expansion need and to facilitate periodic testing.

5.1.4.2 **Accessibility.** All valves, except valves in zone valve box assemblies, shall be located in secured areas such as locked piped chases, or be locked or latched in their operating position, and be labeled as to gas supplied and the area(s) controlled.

5.1.4.2.1 Shutoff valves accessible to other than authorized personnel shall be installed in valve boxes with frangible or removable windows large enough to allow manual operation of valves.

5.1.4.2.2 Shutoff valves for use in certain areas, such as psychiatric or pediatric areas, shall be permitted to be secured with the approval of the authority having jurisdiction to prevent inappropriate access.

5.1.4.2.3 Valves for nonflammable medical gases shall not be installed in the same zone valve box assembly with flammable gases.

5.1.4.3 **Valve Types.** New or replacement shutoff valves shall be as follows:

- (1) They shall be of the quarter turn, full ported, ball type.
- (2) They shall be of brass or bronze construction.
- (3) They shall have extensions for brazing.
- (4) They shall have a handle indicating open or closed.
- (5) They shall consist of three pieces permitting in-line serviceability.

5.1.4.3.1 Valves for positive pressure gases shall be cleaned for oxygen service by the manufacturer.

5.1.4.3.2 Valves for vacuum or WAGD service shall be permitted to be ball or butterfly type and shall not be required to be cleaned for oxygen service.

5.1.4.4 **Source Valve.** A shutoff valve shall be placed at the immediate connection of each source system to the piped distribution system to allow the entire source, including all accessory devices (e.g., air dryers, final line regulators), to be isolated from the facility.

5.1.4.4.1 The source valve shall be located in the immediate vicinity of the source equipment.

5.1.4.4.2 The source valve shall be labeled in accordance with 5.1.11.2.

5.1.4.5\* **Main Line Valve.** A shutoff valve shall be provided in the main supply line inside of the building, except where one or more of the following conditions exist:

- (1) The source and source valve are located inside the building served.
- (2) The source system is physically mounted to the wall of the building served, and the pipeline enters the building in the immediate vicinity of the source valve.

5.1.4.5.1 The main line valve shall be located to allow access by authorized personnel only (i.e., by locating the valve above a ceiling or behind a locked access door).

5.1.4.5.2 The main line valve shall be located on the facility side of the source valve and outside of the source room, the enclosure, or where the main line first enters the building.

5.1.4.5.3 The main line valve shall be labeled in accordance with 5.1.11.2.

5.1.4.6 **Riser Valve.** Each riser supplied from the main line shall be provided with a shutoff valve in the riser adjacent to the main line.

5.1.4.6.1 Riser valves shall be permitted to be located above ceilings, but shall remain accessible and not be obstructed.

5.1.4.6.2 The riser valve shall be labeled in accordance with 5.1.11.2.

**5.1.4.7 Service Valves.** Service valves shall be installed to allow servicing or modification of lateral branch piping from a main or riser without shutting down the entire main, riser, or facility.

**5.1.4.7.1** Only one service valve shall be required for each branch off of a riser, regardless of how many zone valve boxes are installed on that lateral.

**5.1.4.7.2** Service valves shall be placed in the branch piping prior to any zone valve box assembly on that branch.

**5.1.4.7.3** Service valves shall be located in any one of the following areas:

- (1) Behind a locked access door
- (2) Locked open above a ceiling
- (3) Locked open in a secure area

**5.1.4.7.4** Service valves shall be labeled in accordance with 5.1.11.2.

**5.1.4.8 Zone Valves.** All station outlets/inlets shall be supplied through a zone valve as follows:

- (1) The zone valve shall be placed such that a wall intervenes between the valve and outlets/inlets that it controls.
- (2) The zone valve shall serve only outlets/inlets located on that same story.
- (3) The zone valve shall not be located in a room with station outlets/inlets that it controls.

**5.1.4.8.1** Zone valves shall be readily operable from a standing position in the corridor on the same floor they serve.

**5.1.4.8.2** Zone valves shall be so arranged that shutting off the supply of medical gas or vacuum to one zone will not affect the supply of medical gas or vacuum to another zone or the rest of the system.

**5.1.4.8.3** A pressure/vacuum indicator shall be provided on the station outlet/inlet side of each zone valve.

**5.1.4.8.4** Zone valve boxes shall be installed where they are visible and accessible at all times.

**5.1.4.8.5** Zone valve boxes shall not be installed behind normally open or normally closed doors or otherwise hidden from plain view.

**5.1.4.8.6** Zone valve boxes shall not be located in closed or locked rooms, areas, or closets.

**5.1.4.8.7** A zone valve shall be located immediately outside each vital life-support area, critical care area, and anesthetizing location of moderate sedation, deep sedation, or general anesthesia, in each medical gas or vacuum line, or both, and located so as to be readily accessible in an emergency.

**5.1.4.8.7.1** All gas delivery columns, hose reels, ceiling tracks, control panels, pendants, booms, or other special installations shall be located downstream of the zone valve.

**5.1.4.8.7.2** Zone valves shall be so arranged that shutting off the supply of gas to any one operating room or anesthetizing location will not affect the others.

**5.1.4.8.8** Zone valves shall be labeled in accordance with 5.1.11.2.

**5.1.4.9 In-Line Shutoff Valves.** Optional in-line valves shall be permitted to be installed to isolate or shut off piping for servicing of individual rooms or areas.

**5.1.4.9.1** In-line shutoff valves intended for use to isolate piping for maintenance or modification shall meet the following requirements:

- (1) They shall be located in a restricted area.
- (2) They shall be locked or latched open.
- (3) They shall be identified in accordance with 5.1.11.2.

**5.1.4.10 Valves for Future Connections.** Shutoff valves provided for the connection of future piping shall meet the following requirements:

- (1) They shall be located in a restricted area.
- (2) They shall be locked or latched closed.
- (3) They shall be identified in accordance with 5.1.11.2.

**5.1.4.10.1** Future connection valves shall be labeled as to gas content.

**5.1.4.10.2** Downstream piping shall be closed with a brazed cap with tubing allowance for cutting and rebrazing.

**5.1.4.11 In-Line Check Valves.** New or replacement check valves shall be as follows:

- (1) They shall be of brass or bronze construction.
- (2) They shall have brazed extensions.
- (3) They shall have in-line serviceability.
- (4) They shall not have threaded connections.
- (5) They shall have threaded purge points of 1/8 in. NPT.

**5.1.5\* Station Outlets/Inlets.**

**5.1.5.1** Each station outlet/inlet for medical gases or vacuums shall be gas-specific, whether the outlet/inlet is threaded or is a noninterchangeable quick coupler.

**5.1.5.2** Each station outlet shall consist of a primary and a secondary valve (or assembly).

**5.1.5.3** Each station inlet shall consist of a primary valve (or assembly) and shall be permitted to include a secondary valve (or assembly).

**5.1.5.4** The secondary valve (or assembly) shall close automatically to stop the flow of gas (or vacuum, if provided) when the primary valve (or assembly) is removed.

**5.1.5.5** Each outlet/inlet shall be legibly identified in accordance with 5.1.11.3.

**5.1.5.6** Threaded outlets/inlets shall be non-interchangeable connections complying with CGA V-5, *Diameter-Index Safety System (Noninterchangeable Low Pressure Connections for Medical Gas Applications)*.

**5.1.5.7** Each station outlet/inlet, including those mounted in columns, hose reels, ceiling tracks, or other special installations, shall be designed so that parts or components that are required to be gas-specific for compliance with 5.1.5.1 and 5.1.5.9 cannot be interchanged between the station outlet/inlet for different gases.

**5.1.5.8** The use of common parts in outlets/inlets, such as springs, O-rings, fasteners, seals, and shutoff poppets, shall be permitted.

**5.1.5.9** Components of a vacuum station inlet necessary for the maintenance of vacuum specificity shall be legibly marked to identify them as components or parts of a vacuum or suction system.

**5.1.5.10** Components of inlets not specific to a vacuum shall not be required to be marked.

**5.1.5.11** Factory-installed copper inlet tubes on station outlets extending no further than 205 mm (8 in.) from the body of the terminal shall be not less than DN8 (NPS ¼) (⅜ in. O.D.) size, with 8 mm (0.3 in.) minimum inside diameter.

**5.1.5.12** Factory-installed copper inlet tubes on station inlets extending no further than 205 mm (8 in.) from the body of the terminal shall be not less than DN10 (NPS ⅜) (½ in. O.D.) size, with 10 mm (0.4 in.) minimum inside diameter.

**5.1.5.13** Station outlets/inlets shall be permitted to be recessed or otherwise protected from damage.

**5.1.5.14** When multiple wall outlets/inlets are installed, they shall be spaced to allow the simultaneous use of adjacent outlets/inlets with any of the various types of therapy equipment.

**5.1.5.15** Station outlets in systems having nonstandard operating pressures shall meet the following additional requirements:

- (1) They shall be gas-specific.
- (2) They shall be pressure-specific where a single gas is piped at more than one operating pressure [e.g., a station outlet for oxygen at 550 kPa (80 psi) shall not accept an adapter for oxygen at 345 kPa (50 psi)].
- (3) If operated at a pressure in excess of 550 kPa (80 psi), they shall be either D.I.S.S. connectors or comply with 5.1.5.15(4).
- (4) If operated at a gauge pressure between 1380 kPa and 2070 kPa (200 psi and 300 psi), the station outlet shall be designed so as to prevent the removal of the adapter until the pressure has been relieved to prevent the adapter injuring the user or others when removed from the outlet.

**5.1.5.16** WAGD networks shall provide a WAGD inlet in all locations where nitrous oxide or halogenated anesthetic gas is intended to be administered.

**5.1.5.16.1** Station inlets for WAGD service shall have the following additional characteristics:

- (1) They shall not be interchangeable with any other systems, including medical-surgical vacuum.
- (2) Components necessary for the maintenance of WAGD specificity shall be legibly marked to identify them as components of a WAGD inlet.
- (3) They shall be of a type appropriate for the flow and vacuum level required by the facility's gas anesthetic machines.
- (4) They shall be located to avoid physical damage to the inlet.

**5.1.6\* Manufactured Assemblies.**

**5.1.6.1** Manufactured assemblies shall be pretested by the manufacturer prior to arrival at the installation site in accordance with the following:

- (1) Initial blowdown test per 5.1.12.2.2
- (2) Initial pressure test per 5.1.12.2.3
- (3) Piping purge test per 5.1.12.2.5
- (4) Standing pressure test per 5.1.12.2.6 or 5.1.12.2.7, except as permitted under 5.1.6.2

**5.1.6.2** The standing pressure test under 5.1.6.1(4) shall be permitted to be performed by any testing method that will ensure a pressure decay of less than 1 percent in 24 hours.

**5.1.6.3** The manufacturer of the assembly shall provide documentation certifying the performance and successful completion of the tests required in 5.1.6.1.

**5.1.6.4** Manufactured assemblies employing flexible hose shall use hose and flexible connectors with a minimum burst gauge pressure of 6895 kPa (1000 psi).

**5.1.6.5** Manufactured assemblies shall have a flame spread index of not greater than 200 when tested in accordance with ASTM E 84, *Standard Test Method for Surface Burning Characteristics of Building Materials*, or shall comply with the requirements for heat release in accordance with NFPA 286, *Standard Methods of Fire Tests for Evaluating Contribution of Wall and Ceiling Interior Finish to Room Fire Growth*, as described in Section 10.2 of NFPA 101, *Life Safety Code*.

**5.1.6.6** Manufactured assemblies employing flexible hose or tubing shall be attached to the pipelines using station outlets/inlets.

**5.1.6.7** Manufactured assemblies employing hose or flexible connectors, where the station outlet/inlet attached to the piping is not fully and immediately accessible (i.e., cannot be manipulated without the removal of panels, doors, and so forth), shall have station outlets/inlets with the following additional characteristics:

- (1) They shall be gas-specific connections with positive locking mechanisms that ensure the connector is firmly seated and cannot detach without intentional actuation of the release (e.g., D.I.S.S. connectors).
- (2) In pressure gases, they shall be permitted to omit the secondary valve (or assembly) required in 5.1.5.2.
- (3) In vacuum and WAGD, they shall be permitted to omit both primary and secondary valves (or assemblies) for minimum restriction to flow.
- (4) They shall be provided with a second terminal at which the user connects and disconnects that complies with 5.1.5.

**5.1.6.8** Manufactured assemblies connected to the pipeline by brazing shall have station outlets/inlets that comply with 5.1.5 in all respects.

**5.1.6.9** The installation of manufactured assemblies shall be tested in accordance with 5.1.12.

**5.1.7\* Surface-Mounted Medical Gas Rails (MGR).**

**5.1.7.1** Medical gas rail (MGR) assemblies shall be permitted to be installed where multiple uses of medical gases and vacuum at a single patient location are required or anticipated.

**5.1.7.2** MGR assemblies shall be entirely visible in the room, not passing into or through walls, partitions, and so forth.

**5.1.7.3** MGR assemblies shall be made of materials with a melting point of at least 538°C (1000°F).

**5.1.7.4** MGR assemblies shall be cleaned per 5.1.10.1.1.

**5.1.7.5** Station outlets or inlets shall not be placed on the ends of MGR assemblies.

**5.1.7.6** Openings for station outlets/inlets in the MGR shall be gas-specific.

**5.1.7.7** Openings in the MGR not occupied by station outlets/inlets (e.g., for future use) shall be capped or plugged so that a special tool is required for removal (i.e., cannot be removed by a wrench, pliers, a screwdriver, or other common tool).

**5.1.7.8** MGR assemblies shall connect to the pipeline through fittings that are brazed to the pipeline.

**5.1.7.9\*** Where the pipeline and the MGR assembly are of dissimilar metals, the connections shall be plated or otherwise protected from interaction between the metals.

**5.1.7.10** The installation of the MGR shall be tested in accordance with 5.1.12.

### **5.1.8 Pressure and Vacuum Indicators.**

#### **5.1.8.1 General.**

**5.1.8.1.1** Pressure indicators and manometers for medical gas piping systems shall be cleaned for oxygen service.

**5.1.8.1.2** Gauges shall comply with ANSI/ASME B40.100, *Pressure Gauges and Gauge Attachments*.

**5.1.8.1.3\*** The scale range of positive pressure analog indicators shall be such that the normal operating pressure is within the middle third of the total range [e.g., an indicator of 0 to 2070 kPa (0 to 300 psi) would have a lower third of 0 to 690 kPa (0 to 100 psig), a middle third of 690 kPa to 1380 kPa (100 psig to 200 psig), and a top third of 1380 kPa to 2070 kPa (200 psig to 300 psig)].

**5.1.8.1.4** The accuracy of digital indicators shall be  $\pm 5$  percent of the operating pressure at which they are used.

**5.1.8.1.5** The scale range of vacuum indicators shall be 0 to 760 mm (0 to 30 in.) gauge HgV. Indicators with a normal range display shall indicate normal only above 300 mm (12 in.) gauge HgV.

**5.1.8.1.6** Indicators adjacent to master alarm actuators and area alarms shall be labeled to identify the name of, or chemical symbol for, the particular piping system that they monitor.

**5.1.8.1.7** The rated accuracy of indicators used for testing shall be 1 percent (full scale) or better at the point of reading.

#### **5.1.8.2 Locations.**

**5.1.8.2.1** Pressure/vacuum indicators shall be readable from a standing position.

**5.1.8.2.2** Pressure/vacuum indicators shall be provided at the following locations, as a minimum:

- (1) Adjacent to the alarm-initiating device for source main line pressure and vacuum alarms in the master alarm system
- (2) At or in area alarm panels to indicate the pressure/vacuum at the alarm-activating device for each system that is monitored by the panel
- (3) On the station outlet/inlet side of zone valves

**5.1.8.2.3** All pressure-sensing devices and main line pressure gauges downstream of the source valves shall be provided with a gas-specific demand check fitting to facilitate service testing or replacement.

**5.1.8.2.3.1** Gas-specific demand check fittings shall not be required on zone valve pressure indicators.

**5.1.8.2.4** Demand check fittings shall be provided for all monitors.

#### **5.1.9\* Category 1 Warning Systems.**

**5.1.9.1 General.** All master, area, and local alarm systems used for medical gas and vacuum systems shall include the following:

- (1) Separate visual indicators for each condition monitored, except as permitted in 5.1.9.5.2 for local alarms that are displayed on master alarm panels

- (2) Visual indicators that remain in alarm until the situation that has caused the alarm is resolved
- (3) Cancelable audible indication of each alarm condition that produces a sound with a minimum level of 80 dBA at 0.92 m (3 ft)
- (4) Means to visually indicate a lamp or LED failure
- (5) Visual and audible indication that the communication with an alarm-initiating device is disconnected
- (6) Labeling of each indicator, indicating the condition monitored
- (7) Labeling of each alarm panel for its area of surveillance
- (8) Reinitiation of the audible signal if another alarm condition occurs while the audible alarm is silenced
- (9) Power for master, area alarms, sensors, and switches from the life safety branch of the emergency electrical system as described in Chapter 6
- (10) Power for local alarms, dew point sensors, and carbon monoxide sensors permitted to be from the same essential electrical branch as is used to power the air compressor system
- (11) Where used for communications, wiring from switches or sensors that is supervised or protected as required by 517.30(C)(3) of *NFPA 70, National Electrical Code*, for life safety and critical branches circuits in which protection is any of the following types:
  - (a) Conduit
  - (b) Free air
  - (c) Wire
  - (d) Cable tray
  - (e) Raceways
- (12) Communication devices that do not use electrical wiring for signal transmission will be supervised such that failure of communication shall initiate an alarm.
- (13) Assurance by the responsible authority of the facility that the labeling of alarms, where room numbers or designations are used, is accurate and up-to-date
- (14) Provisions for automatic restart after a power loss of 10 seconds (e.g., during generator start-up) without giving false signals or requiring manual reset
- (15) Alarm switches/sensors installed so as to be removable

**5.1.9.2\* Master Alarms.** A master alarm system shall be provided to monitor the operation and condition of the source of supply, the reserve source (if any), and the pressure in the main lines of each medical gas and vacuum piping system.

**5.1.9.2.1** The master alarm system shall consist of two or more alarm panels located in at least two separate locations, as follows:

- (1) One master alarm panel shall be located in the office or work space of the on-site individual responsible for the maintenance of the medical gas and vacuum piping systems.
- (2) In order to ensure continuous surveillance of the medical gas and vacuum systems while the facility is in operation, the second master alarm panel shall be located in an area of continuous observation (e.g., the telephone switchboard, security office, or other continuously staffed location).

**5.1.9.2.2** A centralized computer system shall be permitted to be substituted for one of the master alarms required in 5.1.9.2.1 if the computer system complies with 5.1.9.4.

**5.1.9.2.3** The master alarm panels required in 5.1.9.2.1 shall communicate directly to the alarm-initiating devices that they monitor.

**5.1.9.2.3.1** Each of the two mandatory alarms shall be wired independently to the initiating device(s) for each signal.

**5.1.9.2.3.2** The wiring between each mandatory alarm(s) and the initiating device(s) shall not utilize common conductors that, if interrupted, would disable more than one signal.

**5.1.9.2.3.3** Each set of wires (in whatever number as required by the alarm) shall run to the initiating device(s) without interruption other than in-line splices necessary to complete the necessary length of wire.

**5.1.9.2.3.4** A single initiating device shall be permitted to actuate multiple master alarms.

**5.1.9.2.3.5** The mandatory master alarm panels shall not be arranged such that failure of either panel would disable any signal on the other panel.

**5.1.9.2.3.6** Where initiating devices are remote from the building and the wiring is to run underground in compliance with *NFPA 70*, the following exceptions shall be permitted to be used:

- (1) Wiring from the initiating device and through the underground section shall be permitted to be run to a junction box located where the wiring first enters the building.
- (2) A single set of wires complying with 5.1.9.2.3.2 and 5.1.9.2.3.3 for each signal shall be permitted to connect the initiating device and the junction box.
- (3) Between the junction box and the two mandatory alarm panels, wiring shall comply with 5.1.9.2.3.1 through 5.1.9.2.3.5 in all respects.

**5.1.9.2.3.7** Where a relay is required to ensure correct operation of an initiating device, the control power for the relay shall not be such that disabling any master alarm panel would disable the relay.

**5.1.9.2.3.8** Master alarm signals shall not be relayed from one master alarm panel to another.

**5.1.9.2.3.9** Where multi-pole alarm relays are used to isolate the alarm-initiating signals to master alarm panels, the control power source for the relays shall be independent of any of the master alarm panels.

**5.1.9.2.3.10** Multiple master alarms shall be permitted to monitor a single initiating device.

**5.1.9.2.4** Master alarm panels for medical gas and vacuum systems shall each include the following signals:

- (1) Alarm indication when, or just before, changeover occurs in a medical gas system that is supplied by a manifold or other alternating-type bulk system that has as a part of its normal operation a changeover from one portion of the operating supply to another
- (2) Alarm indication for a bulk cryogenic liquid system when the main supply reaches an average day's supply, indicating low contents
- (3) Alarm indication when, or just before, the changeover to the reserve supply occurs in a medical gas system that consists of one or more units that continuously supply the piping system while another unit remains as the reserve supply and operates only in the case of an emergency
- (4) Alarm indication for cylinder reserve pressure low when the content of a cylinder reserve header is reduced below one average day's supply
- (5) For bulk cryogenic liquid systems, an alarm when or at a predetermined set point before the reserve supply contents fall to one day's average supply, indicating reserve low

- (6) Where a cryogenic liquid storage unit is used as a reserve for a bulk supply system, an alarm indication when the gas pressure available in the reserve unit is below that required for the medical gas system to function
- (7) Alarm indication when the pressure in the main line of each separate medical gas system increases 20 percent or decreases 20 percent from the normal operating pressure
- (8) Alarm indication when the medical-surgical vacuum pressure in the main line of each vacuum system drops to or below 300 mm (12 in.) gauge HgV
- (9) Alarm indication(s) from the local alarm panel(s) as described in 5.1.9.5.2 to indicate when one or more of the conditions being monitored at a site is in alarm
- (10) Medical air dew point high alarm from each compressor site to indicate when the line pressure dew point is greater than +2°C (+35°F)
- (11) WAGD low alarm when the WAGD vacuum level or flow is below effective operating limits
- (12) An instrument air dew point high alarm from each compressor site to indicate when the line pressure dew point is greater than -30°C (-22°F)
- (13) Alarm indication if the primary or reserve production stops on a proportioning system

**5.1.9.2.5** The alarm indications required in 5.1.9.2.4(7) and 5.1.9.2.4(8) shall originate from sensors installed in the main lines immediately downstream (on the patient or use side) of the source valves. Where it is necessary to install a main line valve in addition to a source valve (*see 5.1.4.5*), the sensors shall be located downstream (on the patient or use side) of the main valve.

**5.1.9.3\* Area Alarms.** Area alarm panels shall be provided to monitor all medical gas, medical-surgical vacuum, and piped WAGD systems supplying the following:

- (1) Anesthetizing locations where moderate sedation, deep sedation, or general anesthesia is administered
- (2)\*Critical care areas

**5.1.9.3.1\*** Area alarms shall be located at a nurse's station or other similar location that will provide for surveillance.

**5.1.9.3.2** Area alarm panels for medical gas systems shall indicate if the pressure in the lines in the area being monitored increases or decreases by 20 percent from the normal line pressure.

**5.1.9.3.3** Area alarm panels for medical-surgical vacuum systems shall indicate if the vacuum in the area drops to or below 300 mm (12 in.) gauge HgV.

**5.1.9.3.4** Alarm sensors for area alarms shall be located as follows:

- (1)\*Critical care areas shall have the alarm sensors installed on the patient or use side of each individual zone valve box assemblies.
- (2)\*Anesthetizing locations where moderate sedation, deep sedation, or general anesthesia is administered shall have the sensors installed either on the source side of any of the individual room zone valve box assemblies or on the patient or use side of each of the individual zone valve box assemblies.

**5.1.9.3.5** Area alarm panels for medical gas systems shall provide visual and audible indication in the event a mismatch occurs between the transducer(s) and its associated circuit board(s).

**5.1.9.4 Master Alarms by Computer Systems.** Computer systems used as substitute master alarms as required by 5.1.9.2.1(2) shall have the mechanical and electrical characteristics described in 5.1.9.4.1 and the programming characteristics described in 5.1.9.4.2.

**5.1.9.4.1** Computer systems used to substitute for alarms shall have the following mechanical and electrical characteristics:

- (1) The computer system shall be in continuous uninterrupted operation and provided with power supplies as needed to ensure such reliability.
- (2) The computer system shall be continuously attended by responsible individuals or shall provide remote signaling of responsible parties (e.g., through pagers, telephone autodialers, or other such means).
- (3) Where computer systems rely on signal interface devices (e.g., electronic interfaces, other alarm panels, 4 mA to 20 mA cards), such interfaces shall be supervised such that failure of the device(s) shall initiate an alarm(s).
- (4) If the computer system does not power the signaling switches/sensors from the same power supply required in 5.1.9.4.1(1), the power supply for the signaling switches/sensors shall be powered from the life safety branch of the emergency electrical system as described in Chapter 6.
- (5) Computer systems shall be permitted to communicate directly to the sensors/switches in 5.1.9.2.3 in the same manner as an alarm panel if operation of another alarm panel(s) is not impaired.
- (6) Communication from the computer system to the signaling switches or sensors shall be supervised such that failure of communication shall initiate an alarm.
- (7) Computer systems shall be provided with an audio alert per 5.1.9.1(3), except the audio alert shall be permitted to be only as loud as needed to alert the system operator.
- (8) The facility shall ensure compliance with 5.1.9.1(12).

**5.1.9.4.2** The operating program(s) for computer systems used to substitute for alarms shall include the following:

- (1) Medical gas alarms shall be allocated the priority of a life safety signal.
- (2) A medical gas alarm signal shall interrupt any other activity of a lesser priority to run the alarm algorithm(s).
- (3) The alarm algorithm shall include activation of an audible alert, activation of any remote signaling protocol, and display of the specific condition in alarm.
- (4) The alarm algorithm shall provide for compliance with 5.1.9.1(1), 5.1.9.1(2), 5.1.9.1(3), 5.1.9.1(5), 5.1.9.1(6), and 5.1.9.1(8).

**5.1.9.5\* Local Alarms.** Local alarms shall be installed to monitor the function of the air compressor system(s), medical-surgical vacuum pump system(s), WAGD systems, instrument air systems, and proportioning systems.

**5.1.9.5.1** The signals referenced in 5.1.9.5.4 shall be permitted to be located as follows:

- (1) On or in the control panel(s) for the machinery being monitored
- (2) Within a monitoring device (e.g., dew point monitor or carbon monoxide monitor)
- (3) On a separate alarm panel(s)

**5.1.9.5.2** The master alarm shall include at least one signal from the source equipment to indicate a problem with the source equipment at this location. This master alarm signal shall activate when any of the required local alarm signals for this source equipment activates.

**5.1.9.5.3** If there is more than one medical air compressor system, instrument air compressor system, WAGD system, medical-surgical vacuum pump system, or proportioning system at different locations in the facility, or if the compressors and vacuum

sources are in different locations in the facility, then it shall be necessary for each location to have separate alarms at the master panels.

**5.1.9.5.4** The following functions shall be monitored at each local alarm site:

- (1) Backup or lag compressor in operation, to indicate when the primary or lead air compressor is incapable of satisfying the demand of the requirements of the system, except when the medical air system consists of three or more compressors, in which case the backup or lag signal is permitted to energize when the last compressor has been signaled to start
- (2) High carbon monoxide level, to indicate when the carbon monoxide level in the medical air system is 10 ppm or higher
- (3) Medical air dew point high, to indicate when the line pressure dew point is greater than +2°C (+35°F)
- (4) Backup or lag vacuum pump in operation, to indicate when the primary or lead vacuum pump is incapable of satisfying the demand of the requirements of the system, except when the vacuum pump system consists of three or more pumps, in which case the backup or lag signal is permitted to energize when the last pump has been signaled to start
- (5) When a central dedicated WAGD producer is provided per 5.1.3.8.1.3, WAGD lag in use with the signal to be manually reset
- (6) Instrument air dew point high, to indicate when the line pressure dew point is greater than -30°C (-22°F)
- (7) For compressor systems using liquid ring compressors or compressors with water-cooled components, high water in the receiver tank, to indicate when the water level in the receiver tank, has reached a level determined to be detrimental to the operation of the system
- (8) For compressor systems using liquid ring compressors, high water in the separators
- (9) For compressor systems using other than liquid ring compressors, high discharge air temperature
- (10) Proportioning systems high/low indicator when the oxygen concentration is outside 19.5 percent to 23.5 percent oxygen
- (11) Proportion systems reserve system in operation

#### **5.1.10 Category 1 Distribution.**

##### **5.1.10.1 Piping Materials for Field-Installed Positive Pressure Medical Gas Systems.**

**5.1.10.1.1** Tubes, valves, fittings, station outlets, and other piping components in medical gas systems shall have been cleaned for oxygen service by the manufacturer prior to installation in accordance with CGA G-4.1, *Cleaning Equipment for Oxygen Service*, except that fittings shall be permitted to be cleaned by a supplier or agency other than the manufacturer.

**5.1.10.1.2** Each length of tube shall be delivered plugged or capped by the manufacturer and kept sealed until prepared for installation.

**5.1.10.1.3** Fittings, valves, and other components shall be delivered sealed and labeled and kept sealed until prepared for installation.

**5.1.10.1.4\*** Tubes shall be hard-drawn seamless copper in accordance with ASTM B 819, *Standard Specification for Seamless Copper Tube for Medical Gas Systems*, medical gas tube, Type L, except Type K shall be used where operating pressures are above a gauge pressure of 1275 kPa (185 psi) and the pipe sizes are larger than DN80 [NPS 3 (3½ in. O.D.)].

**5.1.10.1.5** ASTM B 819, *Standard Specification for Seamless Copper Tube for Medical Gas Systems*, medical gas tube shall be identified by the manufacturer's markings "OXY," "MED," "OXY/MED," "OXY/ACR," or "ACR/MED" in blue (Type L) or green (Type K).

**5.1.10.1.6** The installer shall furnish documentation certifying that all installed piping materials comply with the requirements of 5.1.10.1.1.

**5.1.10.2 Piping Materials for Field-Installed Medical-Surgical Vacuum and WAGD Systems.**

**5.1.10.2.1 Tubes for Vacuum.** Piping for vacuum systems shall be constructed of any of the following:

- (1) Hard-drawn seamless copper tube in accordance with the following:
  - (a) ASTM B 88, *Standard Specification for Seamless Copper Water Tube*, copper tube (Type K, Type L, or Type M)
  - (b) ASTM B 280, *Standard Specification for Seamless Copper Tubing for Air Conditioning and Refrigeration Field Service*, copper ACR tube
  - (c) ASTM B 819, *Standard Specification for Seamless Copper Tube for Medical Gas Systems*, copper medical gas tubing (Type K or Type L)
- (2) Stainless steel tube

**5.1.10.2.2 Vacuum Tube Marking Where Required.**

**5.1.10.2.2.1** If copper vacuum tubing is installed along with any medical gas tubing, the vacuum tubing shall, prior to installation, be prominently labeled or otherwise identified to preclude using materials or installation procedures in the medical gas system that are not suitable for oxygen service.

**5.1.10.2.2.2** If medical gas tube in accordance with ASTM B 819, *Standard Specification for Seamless Copper Tube for Medical Gas Systems*, is used for vacuum piping, such special marking shall not be required, provided that the vacuum piping installation meets all other requirements for medical gas piping, including the prohibition of flux on copper-to-copper joints and the use of a nitrogen purge while brazing.

**5.1.10.2.3 WAGD System Piping.** WAGD systems shall be piped as follows:

- (1) Using materials compliant with 5.1.10.2.1 or 5.1.10.2.2
- (2) In systems operated under 130 mm (5 in.) HgV maximum vacuum only, using any noncorroding tube or ductwork

**5.1.10.3 Joints.**

**5.1.10.3.1\*** Positive pressure patient gas systems, medical support gas systems, vacuum systems, and WAGD systems shall have all turns, offsets, and other changes in direction made using fittings or techniques appropriate to any of the following acceptable joining methods:

- (1) Brazing, as described in 5.1.10.4
- (2) Welding, as described in 5.1.10.5
- (3) Memory metal fittings, as described in 5.1.10.6
- (4) Axially swaged, elastic preload fittings, as described in 5.1.10.7
- (5) Threaded, as described under 5.1.10.8

**5.1.10.3.2** Vacuum systems and WAGD systems shall be permitted to have branch connections made using mechanically formed, drilled, and extruded tee-branch connections that are formed in accordance with the tool manufacturer's instructions. Such branch connections shall be joined by brazing, as described in 5.1.10.4.

**5.1.10.3.3** WAGD systems designed for operation below 130 mm (5 in.) HgV shall be permitted to be joined using any method that will result in a leak-free network when tested per 5.1.12.3.2.

**5.1.10.4 Brazed Joints.**

**5.1.10.4.1 General Requirements.**

**5.1.10.4.1.1** Fittings shall be wrought copper capillary fittings complying with ASME B16.22, *Wrought Copper and Copper Alloy Solder-Joint Pressure Fittings*, or brazed fittings complying with ANSI/ASME B16.50, *Wrought Copper and Copper Alloy Braze-Joint Pressure Fittings*.

**5.1.10.4.1.2** Cast copper alloy fittings shall not be permitted.

**5.1.10.4.1.3** Brazed joints shall be made using a brazing alloy that exhibits a melting temperature in excess of 538°C (1000°F) to retain the integrity of the piping system in the event of fire exposure.

**5.1.10.4.1.4** Brazed tube joints shall be the socket type.

**5.1.10.4.1.5** Filler metals shall bond with and be metallurgically compatible with the base metals being joined.

**5.1.10.4.1.6** Filler metals shall comply with ANSI/AWS A5.8, *Specification for Filler Metals for Brazing and Braze Welding*.

**5.1.10.4.1.7** Copper-to-copper joints shall be brazed using a copper-phosphorus or copper-phosphorus-silver brazing filler metal (BCuP series) without flux.

**5.1.10.4.1.8** Brazing performed between bulk cryogenic liquid vessels and their vaporizers (i.e., subject to cryogenic exposure) shall be permitted to be brazed using BAg brazing alloy with flux by a brazer qualified to CGA M-1, *Guide for Medical Gas Installations at Consumer Sites*.

**5.1.10.4.1.9** Joints to be brazed in place shall be accessible for necessary preparation, assembly, heating, filler application, cooling, cleaning, and inspection.

**5.1.10.4.1.10** Braze joints shall be continuously purged with nitrogen NF.

**5.1.10.4.2 Cutting Tube Ends.**

**5.1.10.4.2.1** Tube ends shall be cut square using a sharp tubing cutter to avoid deforming the tube.

**5.1.10.4.2.2** The cutting wheels on tubing cutters shall be free from grease, oil, or other lubricant not suitable for oxygen service.

**5.1.10.4.2.3** The cut ends of the tube shall be permitted to be rolled smooth or deburred with a sharp, clean deburring tool, taking care to prevent chips from entering the tube.

**5.1.10.4.3 Cleaning Joints for Brazing.**

**5.1.10.4.3.1** The interior surfaces of tubes, fittings, and other components that are cleaned for oxygen service shall be stored and handled to avoid contamination prior to assembly and brazing.

**5.1.10.4.3.2** The exterior surfaces of tube ends shall be cleaned prior to brazing to remove any surface oxides.

**5.1.10.4.3.3** When cleaning the exterior surfaces of tube ends, no matter shall be allowed to enter the tube.

**5.1.10.4.3.4** If the interior surfaces of fitting sockets become contaminated prior to brazing, they shall be recleaned for oxygen in accordance with 5.1.10.4.3.10 and be cleaned for brazing with a clean, oil-free wire brush.

**5.1.10.4.3.5** Clean, nonshedding, abrasive pads shall be used to clean the exterior surfaces of the tube ends.

**5.1.10.4.3.6** The use of steel wool or sand cloth shall be prohibited.

**5.1.10.4.3.7** The cleaning process shall not result in grooving of the surfaces to be joined.

**5.1.10.4.3.8** After being abraded, the surfaces shall be wiped using a clean, lint-free white cloth.

**5.1.10.4.3.9** Tubes, fittings, valves, and other components shall be visually examined internally before being joined to verify that they have not become contaminated for oxygen service and that they are free of obstructions or debris.

**5.1.10.4.3.10** The interior surfaces of tube ends, fittings, and other components that were cleaned for oxygen service by the manufacturer, but that became contaminated prior to being installed, shall be permitted to be recleaned on-site by the installer by thoroughly scrubbing the interior surfaces with a clean, hot water-alkaline solution, such as sodium carbonate or trisodium phosphate, using a solution of 450 g (1 lb) of sodium carbonate or trisodium phosphate to 11 L (3 gal) of potable water, and thoroughly rinsing them with clean, hot, potable water.

**5.1.10.4.3.11** Other aqueous cleaning solutions shall be permitted to be used for on-site recleaning permitted in 5.1.10.4.3.10, provided that they are as recommended in CGA G-4.1, *Cleaning Equipment for Oxygen Service*, and are listed in CGA O2-DIR, *Directory of Cleaning Agents for Oxygen Service*.

**5.1.10.4.3.12** Material that has become contaminated internally and is not clean for oxygen service shall not be installed.

**5.1.10.4.3.13** Joints shall be brazed within 8 hours after the surfaces are cleaned for brazing.

#### **5.1.10.4.4 Brazing Dissimilar Metals.**

**5.1.10.4.4.1** Flux shall only be used when brazing dissimilar metals, such as copper and bronze or brass, using a silver (BAG series) brazing filler metal.

**5.1.10.4.4.2** Surfaces shall be cleaned for brazing in accordance with 5.1.10.4.3.

**5.1.10.4.4.3** Flux shall be applied sparingly to minimize contamination of the inside of the tube with flux.

**5.1.10.4.4.4** The flux shall be applied and worked over the cleaned surfaces to be brazed using a stiff bristle brush to ensure complete coverage and wetting of the surfaces with flux.

**5.1.10.4.4.5** Where possible, short sections of copper tube shall be brazed onto the noncopper component, and the interior of the subassembly shall be cleaned of flux prior to installation in the piping system.

**5.1.10.4.4.6** On joints DN20 (NPS  $\frac{3}{4}$ ) ( $\frac{7}{8}$  in. O.D.) size and smaller, flux-coated brazing rods shall be permitted to be used in lieu of applying flux to the surfaces being joined.

#### **5.1.10.4.5\* Nitrogen Purge.**

**5.1.10.4.5.1** When brazing, joints shall be continuously purged with oil-free, dry nitrogen NF to prevent the formation of copper oxide on the inside surfaces of the joint.

**5.1.10.4.5.2** The source of the purge gas shall be monitored, and the installer shall be audibly alerted when the source content is low.

**5.1.10.4.5.3** The purge gas flow rate shall be controlled by the use of a pressure regulator and flowmeter, or combination thereof.

**5.1.10.4.5.4** Pressure regulators alone shall not be used to control purge gas flow rates.

**5.1.10.4.5.5** In order to ensure that all ambient air has been removed from the pipeline prior to brazing, an oxygen analyzer shall be used to verify the effectiveness of the purge. The oxygen analyzer shall read below 1 percent oxygen concentration before brazing begins.

**5.1.10.4.5.6** During and after installation, openings in the piping system shall be kept sealed to maintain a nitrogen atmosphere within the piping to prevent debris or other contaminants from entering the system.

**5.1.10.4.5.7** While a joint is being brazed, a discharge opening shall be provided on the opposite side of the joint from where the purge gas is being introduced.

**5.1.10.4.5.8** The flow of purge gas shall be maintained until the joint is cool to the touch.

**5.1.10.4.5.9** After the joint has cooled, the purge discharge opening shall be sealed to prevent contamination of the inside of the tube and maintain the nitrogen atmosphere within the piping system.

**5.1.10.4.5.10** The final brazed connection of new piping to an existing pipeline containing the system gas shall be permitted to be made without the use of a nitrogen purge.

**5.1.10.4.5.11** After a final brazed connection in a positive pressure medical gas pipeline is made without a nitrogen purge, an outlet in the immediate downstream zone of the affected portion(s) of both the new and existing piping shall be tested in accordance with the final tie-in test in 5.1.12.3.9.

**5.1.10.4.5.12\*** When using the autogenous orbital welding process, joints shall be continuously purged inside and outside with inert gas(es) in accordance with the qualified welding procedure.

#### **5.1.10.4.6 Assembling and Heating Brazed Joints.**

**5.1.10.4.6.1** Tube ends shall be inserted into the socket, either fully or to a mechanically limited depth that is not less than the minimum cup depth (overlap) specified by ANSI/ASME B16.50, *Wrought Copper and Copper Alloy Braze-Joint Pressure Fittings*.

**5.1.10.4.6.2** Where flux is permitted, the joint shall be heated slowly until the flux has liquefied.

**5.1.10.4.6.3** After flux is liquefied, or where flux is not permitted to be used, the joint shall be heated quickly to the brazing temperature, taking care not to overheat the joint.

**5.1.10.4.6.4** Techniques for heating the joint, applying the brazing filler metal, and making horizontal, vertical, and large-diameter joints shall be as stated in sections on applying heat and brazing and horizontal and vertical joints in Chapter VII, "Brazed Joints," in the CDA *Copper Tube Handbook*.

#### **5.1.10.4.7 Inspection of Brazed Joints.**

**5.1.10.4.7.1** After brazing, the outside of all joints shall be cleaned by washing with water and a wire brush to remove any residue and allow clear visual inspection of the joint.

**5.1.10.4.7.2** Where flux has been used, the wash water shall be hot.



**5.1.10.4.7.3** Each brazed joint shall be visually inspected after cleaning the outside surfaces.

**5.1.10.4.7.4** Joints exhibiting the following conditions shall not be permitted:

- (1) Flux or flux residue (when flux or flux-coated BAg series rods are used with dissimilar metals)
- (2) Base metal melting or erosion
- (3) Unmelted filler metal
- (4) Failure of the filler metal to be clearly visible all the way around the joint at the interface between the socket and the tube
- (5) Cracks in the tube or component
- (6) Cracks in the braze filler metal
- (7) Failure of the joint to hold the test pressure under the installer-performed initial pressure test (*see 5.1.12.2.3*) and standing pressure test (*see 5.1.12.2.6 or 5.1.12.2.7*)

**5.1.10.4.7.5** Brazed joints that are identified as defective under the conditions of 5.1.10.4.7.4(2) or (5) shall be replaced.

**5.1.10.4.7.6** Brazed joints that are identified as defective under the conditions of 5.1.10.4.7.4(1), (3), (4), (6), or (7) shall be permitted to be repaired, except that no joint shall be reheated more than once before being replaced.

#### **5.1.10.5 Welded Joints.**

##### **5.1.10.5.1 Gas Tungsten Arc Welding (GTAW) for Copper and Stainless Tube.**

**5.1.10.5.1.1** Welded joints for medical gas and medical-surgical vacuum systems shall be permitted to be made using a gas tungsten arc welding (GTAW) autogenous orbital procedure.

**5.1.10.5.1.2** The GTAW autogenous orbital procedure and the welder qualification procedure shall be qualified in accordance with Section IX, "Welding and Brazing Qualifications," of the ASME *Boiler and Pressure Vessel Code*.

**5.1.10.5.1.3** Welder qualification procedures shall include a bend test and a tensile test in accordance with Section IX, "Welding and Brazing Qualifications," of the ASME *Boiler and Pressure Vessel Code* on each tube size diameter.

**5.1.10.5.1.4** Each welder shall qualify to a welding procedure specification (WPS) for each tube diameter.

**5.1.10.5.1.5\*** GTAW autogenous orbital welded joints shall be purged during welding with a commercially available mixture of 75 percent helium ( $\pm 5$  percent) and 25 percent argon ( $\pm 5$  percent).

**5.1.10.5.1.6** The shield gas shall be as required in 5.1.10.5.1.5.

**5.1.10.5.1.7** Test coupons shall be welded and inspected, as a minimum, at start of work and every 4 hours thereafter, or when the machine is idle for more than 30 minutes, and at the end of the work period.

**5.1.10.5.1.8** Test coupons shall be inspected on the I.D. and O.D. by a qualified quality control inspector.

**5.1.10.5.1.9** Test coupons shall also be welded at change of operator, weld head, welding power supply, or gas source.

**5.1.10.5.1.10** All production welds shall be visually inspected on the O.D. by the operator, and any obvious weld failures shall be cut out and re-welded.

##### **5.1.10.5.2 Welding for Stainless Tube.**

**5.1.10.5.2.1** Stainless tube shall be welded using metal inert gas (MIG) welding, tungsten inert gas (TIG) welding, or other welding techniques suited to joining stainless tube.

**5.1.10.5.2.2** Welders shall be qualified to Section IX, "Welding and Brazing Qualifications," of the ASME *Boiler and Pressure Vessel Code*.

##### **5.1.10.6 Memory Metal Fittings.**

**5.1.10.6.1** Memory metal fittings having a temperature rating not less than 538°C (1000°F) and a pressure rating not less than 2070 kPa (300 psi) shall be permitted to be used to join copper or stainless steel tube.

**5.1.10.6.2** Memory metal fittings shall be installed by qualified technicians in accordance with the manufacturer's instructions.

##### **5.1.10.7 Axially Swaged Fittings.**

**5.1.10.7.1** Axially swaged, elastic strain preload fittings providing metal-to-metal seals, having a temperature rating not less than 538°C (1000°F) and a pressure rating not less than 2070 kPa (300 psi), and that, when complete, are permanent and nonseparable shall be permitted to be used to join copper or stainless steel tube.

**5.1.10.7.2** Axially swaged, elastic strain preload fittings shall be installed by qualified technicians in accordance with the manufacturer's instructions.

**5.1.10.8 Threaded Fittings.** Threaded fittings shall meet the following criteria:

- (1) They shall be limited to connections for pressure and vacuum indicators, alarm devices, check valves, and source equipment on the source side of the source valve.
- (2) They shall be tapered pipe threads complying with ASME B1.20.1, *Pipe Threads, General Purpose, Inch*.
- (3)\*They shall be made up with polytetrafluoroethylene tape or other thread sealant recommended for oxygen service, with sealant applied to the male threads only and care taken to ensure sealant does not enter the pipe.

##### **5.1.10.9 Special Fittings.**

**5.1.10.9.1** Listed or approved metallic gas tube fittings that, when made up, provide a permanent joint having the mechanical, thermal, and sealing integrity of a brazed joint shall be permitted to be used.

**5.1.10.9.2 Dielectric Fittings.** Dielectric fittings that comply with the following shall be permitted only where required by the manufacturer of special medical equipment to electrically isolate the equipment from the system distribution piping:

- (1) They shall be of brass or copper construction with an appropriate dielectric.
- (2) They shall be permitted to be a union.
- (3) They shall be clean for oxygen where used for medical gases and medical support gases.

**5.1.10.10 Prohibited Joints.** The following joints shall be prohibited throughout medical gas and vacuum distribution pipeline systems:

- (1) Flared and compression-type connections, including connections to station outlets and inlets, alarm devices, and other components
- (2) Other straight-threaded connections, including unions

- (3) Pipe-crimping tools used to permanently stop the flow of medical gas and vacuum piping
- (4) Removable and nonremovable push-fit fittings that employ a quick assembly push fit connector

**5.1.10.11 Installation of Piping and Equipment.**

**5.1.10.11.1 Pipe Sizing.**

**5.1.10.11.1.1** Piping systems shall be designed and sized to deliver the required flow rates at the utilization pressures.

**5.1.10.11.1.2** Mains and branches in medical gas piping systems shall be not less than DN15 (NPS ½) (⅝ in. O.D.) size.

**5.1.10.11.1.3** Mains and branches in medical-surgical vacuum systems shall be not less than DN20 (NPS ¾) (⅞ in. O.D.) size.

**5.1.10.11.1.4** Drops to individual station outlets and inlets shall be not less than DN15 (NPS ½) (⅝ in. O.D.) size.

**5.1.10.11.1.5** Runouts to alarm panels and connecting tubing for gauges and alarm devices shall be permitted to be DN8 (NPS ¼) (⅜ in. O.D.) size.

**5.1.10.11.2 Protection of Piping.** Piping shall be protected against freezing, corrosion, and physical damage.

**5.1.10.11.2.1** Piping exposed in corridors and other areas where subject to physical damage from the movement of carts, stretchers, portable equipment, or vehicles shall be protected.

**5.1.10.11.2.2** Piping underground within buildings or embedded in concrete floors or walls shall be installed in a continuous conduit.

**5.1.10.11.3 Location of Piping.**

**5.1.10.11.3.1** Piping risers shall be permitted to be installed in pipe shafts if protected from physical damage, effects of excessive heat, corrosion, or contact with oil.

**5.1.10.11.3.2** Piping shall not be installed in kitchens, elevator shafts, elevator machine rooms, areas with open flames, electrical service equipment over 600 volts, and areas prohibited under *NFPA 70, National Electrical Code*, except for the following locations:

- (1) Room locations for medical air compressor supply systems and medical-surgical vacuum pump supply systems
- (2) Room locations for secondary distribution circuit panels and breakers having a maximum voltage rating of 600 volts

**5.1.10.11.3.3** Medical gas piping shall be permitted to be installed in the same service trench or tunnel with fuel gas lines, fuel oil lines, electrical lines, steam lines, and similar utilities, provided that the space is ventilated (naturally or mechanically) and the ambient temperature around the medical gas piping is limited to 54°C (130°F) maximum.

**5.1.10.11.3.4** Medical gas piping shall not be located where subject to contact with oil, including a possible flooding area in the case of a major oil leak.

**5.1.10.11.4 Pipe Support.**

**5.1.10.11.4.1** Piping shall be supported from the building structure.

**5.1.10.11.4.2** Hangers and supports shall comply with and be installed in accordance with MSS SP-58, *Pipe Hangers and Supports — Materials, Design, Manufacture, Selection, Application, and Installation*.

**5.1.10.11.4.3** Supports for copper tube shall be sized for copper tube.

**5.1.10.11.4.4** In potentially damp locations, copper tube hangers or supports that are in contact with the tube shall be plastic-coated or otherwise be electrically insulated from the tube by a material that will not absorb moisture.

**5.1.10.11.4.5** Maximum support spacing shall be in accordance with Table 5.1.10.11.4.5.

**Table 5.1.10.11.4.5 Maximum Pipe Support Spacing**

Pipe Size	Hanger Spacing	
	mm	ft
DN8 (NPS ¼) (⅜ in. O.D.)	1520	5
DN10 (NPS ⅜) (½ in. O.D.)	1830	6
DN15 (NPS ½) (⅝ in. O.D.)	1830	6
DN20 (NPS ¾) (⅞ in. O.D.)	2130	7
DN25 (NPS 1) (1⅛ in. O.D.)	2440	8
DN32 (NPS 1¼) (1⅜ in. O.D.)	2740	9
DN40 (NPS 1½) (1⅝ in. O.D.) and larger	3050	10
Vertical risers, all sizes, every floor, but not to exceed	4570	15

**5.1.10.11.4.6** Where required, medical gas and vacuum piping shall be seismically restrained against earthquakes in accordance with the applicable building code.

**5.1.10.11.5 Underground Piping Outside of Buildings.**

**5.1.10.11.5.1** Buried piping outside of buildings shall be installed below the local level of frost penetration.

**5.1.10.11.5.2** The installation procedure for underground piping shall protect the piping from physical damage while being backfilled.

**5.1.10.11.5.3** If underground piping is protected by a conduit, cover, or other enclosure, the following requirements shall be met:

- (1) Access shall be provided at the joints for visual inspection and leak testing.
- (2) The conduit, cover, or enclosure shall be self-draining and not retain groundwater in prolonged contact with the pipe.

**5.1.10.11.5.4** Buried piping that will be subject to surface loads shall be buried at a depth that will protect the piping or its enclosure from excessive stresses.

**5.1.10.11.5.5** The minimum backfilled cover above the top of the pipe or its enclosure for buried piping outside of buildings shall be 900 mm (36 in.), except that the minimum cover shall be permitted to be reduced to 450 mm (18 in.) where there is no potential for damage from surface loads or surface conditions.

**5.1.10.11.5.6** Trenches shall be excavated so that the pipe or its enclosure has firm, substantially continuous bearing on the bottom of the trench.

**5.1.10.11.5.7** Backfill shall be clean, free from material that can damage the pipe, and compacted.

**5.1.10.11.5.8** A continuous tape or marker placed immediately above the pipe or its enclosure shall clearly identify the pipeline by specific name.

**5.1.10.11.5.9** A continuous warning means shall also be provided above the pipeline at approximately one-half the depth of burial.

**5.1.10.11.5.10** Where underground piping is installed through a wall sleeve, the outdoor end of the sleeve shall be sealed to prevent the entrance of groundwater into the building.

**5.1.10.11.6 Hose and Flexible Connectors.**

**5.1.10.11.6.1** Hose and flexible connectors, both metallic and nonmetallic, shall be no longer than necessary and shall not penetrate or be concealed in walls, floors, ceilings, or partitions.

**5.1.10.11.6.2** Flexible connectors, metallic or nonmetallic, shall have a minimum burst pressure, with a gauge pressure of 6895 kPa (1000 psi).

**5.1.10.11.6.3** Metallic flexible joints shall be permitted in the pipeline where required for expansion joints, seismic protection, thermal expansion, or vibration control and shall be as follows:

- (1) For all wetted surfaces, made of bronze, copper, or stainless steel
- (2) Cleaned at the factory for oxygen service and received on the job site with certification of cleanliness
- (3) Suitable for service at 2070 kPa (300 psig) or above and able to withstand temperatures of 538°C (1000°F)
- (4) Provided with brazing extensions to allow brazing into the pipeline per 5.1.10.5
- (5) Supported with pipe hangers and supports as required for their additional weight

**5.1.10.11.7 Prohibited System Interconnections.**

**5.1.10.11.7.1** Two or more medical gas or vacuum piping systems shall not be interconnected for installation, testing, or any other reason.

**5.1.10.11.7.2** Leak testing shall be accomplished by separately charging and testing each individual piping system.

**5.1.10.11.8 Manufacturer's Instructions.**

**5.1.10.11.8.1** The installation of individual components shall be made in accordance with the instructions of the manufacturer.

**5.1.10.11.8.2** Manufacturer's instructions shall include directions and information deemed by the manufacturer to be adequate for attaining proper operation, testing, and maintenance of the medical gas and vacuum systems.

**5.1.10.11.8.3** Copies of the manufacturer's instructions shall be left with the system owner.

**5.1.10.11.9 Changes in System Use.**

**5.1.10.11.9.1** Where a positive pressure medical gas piping distribution system originally used or constructed for use at one pressure and for one gas is converted for operation at another pressure or for another gas, all provisions of 5.1.10 shall apply as if the system were new.

**5.1.10.11.9.2** A vacuum system shall not be permitted to be converted for use as a gas system.

**5.1.10.11.10 Qualification of Installers.**

**5.1.10.11.10.1** The installation of medical gas and vacuum systems shall be made by qualified, competent technicians who are experienced in performing such installations, including all personnel who actually install the piping system.

**5.1.10.11.10.2** Installers of medical gas and vacuum piped distribution systems, all appurtenant piping supporting pump and compressor source systems, and appurtenant piping supporting source gas manifold systems not including permanently installed bulk source systems, shall be certified in accordance with ASSE 6010, *Professional Qualification Standard for Medical Gas Systems Installers*.

**5.1.10.11.10.3** Installers of medical gas and vacuum systems shall not use their certification to oversee installation by non-certified personnel.

**5.1.10.11.10.4** Brazing shall be performed by individuals who are qualified in accordance with the provisions of 5.1.10.11.11.

**5.1.10.11.10.5** Prior to any installation work, the installer of medical gas and vacuum piping shall provide and maintain documentation on the job site for the qualification of brazing procedures and individual brazers that is required under 5.1.10.11.11.

**5.1.10.11.10.6** Health care organization personnel shall be permitted to install piping systems if all of the requirements of 5.1.10.11.10 are met during the installation.

**5.1.10.11.11 Qualification of Brazing Procedures and Brazing.**

**5.1.10.11.11.1** Brazing procedures and brazer performance for the installation of medical gas and vacuum piping shall be qualified in accordance with either Section IX, "Welding and Brazing Qualifications," of the ASME *Boiler and Pressure Vessel Code*, or AWS B2.2, *Standard for Brazing Procedure and Performance Qualification*, both as modified by 5.1.10.11.11.2 through 5.1.10.11.11.5.

**5.1.10.11.11.2** Brazers shall be qualified by visual examination of the test coupon followed by sectioning.

**5.1.10.11.11.3** The brazing procedure specification shall address cleaning, joint clearance, overlap, internal purge gas, purge gas flow rate, and filler metal.

**5.1.10.11.11.4** The brazing procedure qualification record and the record of brazer performance qualification shall document filler metal used, cleaning, joint clearance, overlap, internal purge gas and flow rate during brazing of coupon, and absence of internal oxidation in the completed coupon.

**5.1.10.11.11.5** Brazing procedures qualified by a technically competent group or agency shall be permitted under the following conditions:

- (1) The brazing procedure specification and the procedure qualification records meet the requirements of this code.
- (2) The employer obtains a copy of both the brazing procedure specification and the supporting qualification records from the group or agency and signs and dates these records, thereby accepting responsibility for the qualifications that were performed by the group or agency.
- (3) The employer qualifies at least one brazer following each brazing procedure specification used.

**5.1.10.11.11.6** An employer shall be permitted to accept brazer qualification records of a previous employer under the following conditions:

- (1) The brazer has been qualified following the same or an equivalent procedure that the new employer uses.
- (2) The new employer obtains a copy of the record of brazer performance qualification tests from the previous employer and signs and dates these records, thereby accepting responsibility for the qualifications performed by the previous employer.

**5.1.10.11.11.7** Performance qualifications of brazers shall remain in effect indefinitely, unless the brazer does not braze with the qualified procedure for a period exceeding 6 months or there is a specific reason to question the ability of the brazer.

**5.1.10.11.12 Breaching or Penetrating Medical Gas Piping.**

**5.1.10.11.12.1** Positive pressure patient medical gas piping and medical support gas piping shall not be breached or penetrated by any means or process that will result in residual copper particles or other debris remaining in the piping or affect the oxygen-clean interior of the piping.

**5.1.10.11.12.2** The breaching or penetrating process shall ensure that any debris created by the process remains contained within the work area.

**5.1.11\* Labeling and Identification.** Color and pressure requirements shall be in accordance with Table 5.1.11.

**5.1.11.1 Pipe Labeling.**

**5.1.11.1.1** Piping shall be labeled by stenciling or adhesive markers that identify the patient medical gas, the support gas, or the vacuum system and include the following:

- (1) Name of the gas or vacuum system or the chemical symbol per Table 5.1.11
- (2) Gas or vacuum system color code per Table 5.1.11
- (3) Where positive pressure gas piping systems operate at pressures other than the standard gauge pressure in Table 5.1.11, the operating pressure in addition to the name of the gas

**5.1.11.1.2** Pipe labels shall be located as follows:

- (1) At intervals of not more than 6.1 m (20 ft)
- (2) At least once in or above every room
- (3) On both sides of walls or partitions penetrated by the piping
- (4) At least once in every story height traversed by risers

**5.1.11.1.3** Medical gas piping shall not be painted.

**5.1.11.2 Shutoff Valves.**

**5.1.11.2.1** Shutoff valves shall be identified with the following:

- (1) Name or chemical symbol for the specific medical gas or vacuum system
- (2) Room or areas served
- (3) Caution to not close or open the valve except in emergency

**5.1.11.2.2** Where positive pressure gas piping systems operate at pressures other than the standard gauge pressure of 345 kPa to 380 kPa (50 psi to 55 psi) or a gauge pressure of 1100 kPa to 1275 kPa (160 psi to 185 psi) for nitrogen or instrument air, the valve identification shall also include the nonstandard operating pressure.

**5.1.11.2.3** Source valves shall be labeled in substance as follows:

**SOURCE VALVE**

**FOR THE (SOURCE NAME).**

**5.1.11.2.4** Main line valves shall be labeled in substance as follows:

**MAIN LINE VALVE FOR THE (GAS/VACUUM NAME) SERVING (NAME OF THE BUILDING).**

**Table 5.1.11 Standard Designation Colors and Operating Pressures for Gas and Vacuum Systems**

Gas Service	Abbreviated Name	Colors (Background/ Text)	Standard Gauge Pressure	
			kPa	psi
Medical air	Med air	Yellow/black	345–380	50–55
Carbon dioxide	CO <sub>2</sub>	Gray/black or gray/white	345–380	50–55
Helium	He	Brown/white	345–380	50–55
Nitrogen	N <sub>2</sub>	Black/white	1100–1275	160–185
Nitrous oxide	N <sub>2</sub> O	Blue/white	345–380	50–55
Oxygen	O <sub>2</sub>	Green/white or white/green	345–380	50–55
Oxygen/carbon dioxide mixtures	O <sub>2</sub> /CO <sub>2</sub> n% (n = % of CO <sub>2</sub> )	Green/white	345–380	50–55
Medical–surgical vacuum	Med vac	White/black	380 mm to 760 mm (15 in. to 30 in.) HgV	
Waste anesthetic gas disposal	WAGD	Violet/white	Varies with system type	
Other mixtures	Gas A%/Gas B%	Colors as above Major gas for background/minor gas for text	None	
Nonmedical air (Category 3 gas-powered device)		Yellow and white diagonal stripe/black	None	
Nonmedical and Category 3 vacuum		White and black diagonal stripe/black boxed	None	
Laboratory air		Yellow and white checkerboard/black	None	
Laboratory vacuum		White and black checkerboard/black boxed	None	
Instrument air		Red/white	1100–1275	160–185



**5.1.12.2.3 Initial Pressure Test.**

**5.1.12.2.3.1** Each section of the piping in medical gas and vacuum systems shall be pressure tested.

**5.1.12.2.3.2** Initial pressure tests shall be conducted as follows:

- (1) After blow down of the distribution piping
- (2) After installation of station outlet/inlet rough-in assemblies
- (3) Prior to the installation of components of the distribution piping system that would be damaged by the test pressure (e.g., pressure/vacuum alarm devices, pressure/vacuum indicators, line pressure relief valves)

**5.1.12.2.3.3** The source shutoff valve shall remain closed during the tests specified in 5.1.12.2.3.

**5.1.12.2.3.4** The test pressure for pressure gases and vacuum systems shall be 1.5 times the system working pressure but not less than a gauge pressure of 1035 kPa (150 psi).

**5.1.12.2.3.5\*** The test pressure shall be maintained until each joint has been examined for leakage by means of a leak detectant that is safe for use with oxygen and does not contain ammonia.

**5.1.12.2.3.6** Leaks, if any, shall be located, repaired (if permitted), replaced (if required), and retested.

**5.1.12.2.4 Initial Cross-Connection Test.** It shall be determined that no cross-connections exist between the various medical gas and vacuum piping systems.

**5.1.12.2.4.1** All piping systems shall be reduced to atmospheric pressure.

**5.1.12.2.4.2** Sources of test gas shall be disconnected from all piping systems, except for the one system being tested.

**5.1.12.2.4.3** The system under test shall be charged with oil-free, dry nitrogen NF to a gauge pressure of 345 kPa (50 psi).

**5.1.12.2.4.4** After the installation of the individual faceplates with appropriate adapters matching outlet/inlet labels, each individual outlet/inlet in each installed medical gas and vacuum piping system shall be checked to determine that the test gas is being dispensed only from the piping system being tested.

**5.1.12.2.4.5** The cross-connection test referenced in 5.1.12.2.4 shall be repeated for each installed medical gas and vacuum piping system.

**5.1.12.2.4.6** The proper labeling and identification of system outlets/inlets shall be confirmed during these tests.

**5.1.12.2.5 Initial Piping Purge Test.** The outlets in each medical gas piping system shall be purged to remove any particulate matter from the distribution piping.

**5.1.12.2.5.1** Using appropriate adapters, each outlet shall be purged with an intermittent high-volume flow of test gas until the purge produces no discoloration in a clean white cloth.

**5.1.12.2.5.2** The purging required in 5.1.12.2.5.1 shall be started at the closest outlet/inlet to the zone valve and continue to the furthest outlet/inlet within the zone.

**5.1.12.2.6 Standing Pressure Test for Positive Pressure Medical Gas Piping.** After successful completion of the initial pressure tests under 5.1.12.2.3, medical gas distribution piping shall be subject to a standing pressure test.

**5.1.12.2.6.1** Tests shall be conducted after the final installation of station outlet valve bodies, faceplates, and other distri-

bution system components (e.g., pressure alarm devices, pressure indicators, line pressure relief valves, manufactured assemblies, hose).

**5.1.12.2.6.2** The source valve shall be closed during this test.

**5.1.12.2.6.3** The piping systems shall be subjected to a 24-hour standing pressure test using oil-free, dry nitrogen NF.

**5.1.12.2.6.4** Test pressures shall be 20 percent above the normal system operating line pressure.

**5.1.12.2.6.5\*** At the conclusion of the tests, there shall be no change in the test pressure except that attributed to specific changes in ambient temperature.

**5.1.12.2.6.6** Leaks, if any, shall be located, repaired (if permitted) or replaced (if required), and retested.

**5.1.12.2.6.7** The 24-hour standing pressure test of the positive pressure system shall be witnessed by the authority having jurisdiction or its designee. A form indicating that this test has been performed and witnessed shall be provided to the verifier at the start of the tests required in 5.1.12.3.

**5.1.12.2.7 Standing Vacuum Test for Vacuum Piping.** After successful completion of the initial pressure tests under 5.1.12.2.3, vacuum distribution piping shall be subjected to a standing vacuum test.

**5.1.12.2.7.1** Tests shall be conducted after installation of all components of the vacuum system.

**5.1.12.2.7.2** The piping systems shall be subjected to a 24-hour standing vacuum test.

**5.1.12.2.7.3** Test pressure shall be between 300 mm (12 in.) HgV and full vacuum.

**5.1.12.2.7.4** During the test, the source of test vacuum shall be disconnected from the piping system.

**5.1.12.2.7.5\*** At the conclusion of the test, there shall be no change in the vacuum other than that attributed to changes of ambient temperature.

**5.1.12.2.7.6** The 24-hour standing pressure test of the vacuum system shall be witnessed by the authority having jurisdiction or its designee. A form indicating that this test has been performed and witnessed shall be provided to the verifier at the start of the tests required in 5.1.12.3.

**5.1.12.2.7.7** Leaks, if any, shall be located, repaired (if permitted) or replaced (if required), and retested.

**5.1.12.3 System Verification.**

**5.1.12.3.1 General.**

**5.1.12.3.1.1** Verification tests shall be performed only after all tests required in 5.1.12.2, Installer Performed Tests, have been completed.

**5.1.12.3.1.2** The test gas shall be oil-free, dry nitrogen NF or the system gas where permitted.

**5.1.12.3.1.3** Testing shall be conducted by a party technically competent and experienced in the field of medical gas and vacuum pipeline testing and meeting the requirements of ASSE 6030, *Professional Qualifications Standard for Medical Gas Systems Verifiers*.

**5.1.12.3.1.4** Testing shall be performed by a party other than the installing contractor.

**5.1.12.3.1.5** When systems have not been installed by in-house personnel, testing shall be permitted by personnel of that organization who meet the requirements of 5.1.12.3.1.3.

**5.1.12.3.1.6** All tests required under 5.1.12.3 shall be performed after installation of any manufactured assemblies supplied through flexible hose or tubing.

**5.1.12.3.1.7** Where there are multiple possible connection points for terminals, each possible position shall be tested independently.

**5.1.12.3.1.8** The gas of system designation shall be permitted to be used for all tests, regardless of the size of the system, which include the following:

- (1) Standing pressure (*see 5.1.12.3.2*)
- (2) Cross-connection (*see 5.1.12.3.3*)
- (3) Alarms (*see 5.1.12.3.5*)
- (4) Piping purge (*see 5.1.12.3.6*)
- (5) Piping particulates (*see 5.1.12.3.7*)

**5.1.12.3.2\* Standing Pressure Test.** Piping systems shall be subjected to a 10-minute standing pressure test at operating line pressure using the following procedure:

- (1) After the system is filled with nitrogen or source gas, the source valve and all zone valves shall be closed.
- (2) The piping system shall show no decrease in pressure after 10 minutes.
- (3) Any leaks found shall be located, repaired, and retested per 5.1.12.2.6.

**5.1.12.3.3 Cross-Connection Test.** After the closing of walls and completion of the requirements of 5.1.12.2, it shall be determined that no cross-connection of piping systems exists by either of the methods detailed in 5.1.12.3.3.1 or 5.1.12.3.3.2.

**5.1.12.3.3.1 Individual Pressurization Method.**

- (A) All medical gas and vacuum piping systems shall be reduced to atmospheric pressure.
- (B) All sources of test gas from all of the medical gas and vacuum systems, with the exception of the one system to be checked, shall be disconnected.
- (C) The system being checked shall be pressurized to a gauge pressure of 345 kPa (50 psi).
- (D) With adapters matching outlet labels, each individual station outlet/inlet of all medical gas and vacuum systems installed shall be checked to determine that test gas is being dispensed only from the outlets/inlets of the piping system being tested.
- (E) The source of test gas shall be disconnected, and the system tested reduced to atmospheric pressure.
- (F) Proceed to test each additional piping system until all medical gas and vacuum piping systems are free of cross-connections.

**5.1.12.3.3.2 Pressure Differential Method.**

- (A) The pressure in all medical gas systems shall be reduced to atmospheric.
- (B) The test gas pressure in all medical gas piping systems shall be increased to the values indicated in Table 5.1.12.3.3.2(B), simultaneously maintaining these nominal pressures throughout the test.

**Table 5.1.12.3.3.2(B) Alternate Test Pressures**

Medical Gas	Pressure (Gauge)
Gas mixtures	140 kPa (20 psi)
Nitrogen/instrument air	210 kPa (30 psi)
Nitrous oxide	275 kPa (40 psi)
Oxygen	345 kPa (50 psi)
Medical air	415 kPa (60 psi)
Systems at nonstandard pressures	70 kPa (10 psi) greater or less than any other system
Vacuum	HgV vacuum
WAGD	510 mm (20 in.) HgV 380 mm (15 in.) HgV (if so designed)

(C) Systems with nonstandard operating pressures shall be tested at a gauge pressure of at least 70 kPa (10 psi) higher or lower than any other system being tested.

(D) Any vacuum systems shall be in operation so that these vacuum systems are tested at the same time the medical gas systems are tested.

(E) Following the adjustment of pressures in accordance with 5.1.12.3.3.2(B) and 5.1.12.3.3.2(C), each station outlet for each medical gas system shall be tested using the gas-specific connection for each system with test gauge attached to verify that the correct test pressure/vacuum is present at each outlet/inlet of each system as listed in Table 5.1.12.3.3.2(B).

(F) Each test gauge used in performing this test shall be calibrated with the pressure indicator used for the line pressure regulator used to provide the source pressure.

(G) Each station outlet shall be identified by label (and color marking, if used), and the pressure indicated on the test gauge shall be that listed in Table 5.1.12.3.3.2(B) for the system being tested.

**5.1.12.3.4 Valve Test.** Valves installed in each medical gas and vacuum piping system shall be tested to verify proper operation and rooms or areas of control.

**5.1.12.3.4.1** Records shall be made listing the rooms or areas controlled by each valve for each gas.

**5.1.12.3.4.2** The information shall be utilized to assist and verify the proper labeling of the valves.

**5.1.12.3.5 Alarm Test.**

**5.1.12.3.5.1 General.**

- (A) All warning systems for each medical gas and vacuum system(s) shall be tested to ensure that all components function properly prior to placing the system in service.
- (B) Permanent records of these tests shall be maintained.
- (C) Warning systems that are part of an addition to an existing piping system shall be tested prior to the connection of the new piping to the existing system.
- (D) Tests of warning systems for new installations (initial tests) shall be performed after the cross-connection testing (*see 5.1.12.3.3*), but before purging the piping (*see 5.1.12.3.6*) and performing the remaining verification tests. (*See 5.1.12.3.7 through 5.1.12.3.14.*)

(E) Initial tests of warning systems that can be included in an addition or extension to an existing piping system shall be completed before connection of the addition to the existing system.

(F) Test gases for the initial tests shall be oil-free, dry nitrogen NF, the gas of system designation, or operating vacuum.

(G) Where computer systems are used as substitutes for a required alarm panel as permitted under 5.1.9.2.2, the computer system shall be included in the alarm tests as modified in 5.1.9.4.

#### 5.1.12.3.5.2 Master Alarms.

(A) The master alarm system tests shall be performed for each of the medical gas and vacuum piping systems.

(B) Permanent records of these tests shall be maintained with those required under 5.1.12.1.7.

(C) The audible and noncancelable visual signals of 5.1.9.1 shall indicate if the pressure in the main line increases or decreases 20 percent from the normal operating pressure.

(D) The operation of all master alarm signals referenced in 5.1.9.2.4 shall be verified.

**5.1.12.3.5.3 Area Alarms.** The warning signals for all medical gas piping systems shall be tested to verify an alarm condition if the pressure in the piping system increases or decreases 20 percent from the normal operating pressure for positive pressure gases, or when the vacuum system(s) drops below a gauge pressure of 300 mm (12 in.) HgV.

**5.1.12.3.6 Piping Purge Test.** In order to remove any traces of particulate matter deposited in the pipelines as a result of construction, a heavy, intermittent purging of the pipeline shall be done.

**5.1.12.3.6.1** The appropriate adapter shall be obtained from the facility or manufacturer, and high purge rates of at least 225 NI/min (8 SCFM) shall be put on each outlet.

**5.1.12.3.6.2** After the purge is started, it shall be rapidly interrupted several times until the purge produces no discoloration in a white cloth loosely held over the adapter during the purge.

**5.1.12.3.6.3** In order to avoid possible damage to the outlet and its components, this test shall not be conducted using any implement other than the proper adapter.

**5.1.12.3.7 Piping Particulate Test.** For each positive pressure gas system, the cleanliness of the piping system shall be verified.

**5.1.12.3.7.1** A minimum of 1000 L (35 ft<sup>3</sup>) of gas shall be filtered through a clean, white 0.45 micron filter at a minimum flow rate of 100 NI/min (3.5 SCFM).

**5.1.12.3.7.2** Twenty-five percent of the zones shall be tested at the outlet most remote from the source.

**5.1.12.3.7.3** The filter shall accrue no more than 0.001 g (1 mg) of matter from any outlet tested.

**5.1.12.3.7.4** If any outlet fails this test, the most remote outlet in every zone shall be tested.

**5.1.12.3.7.5** The test shall be performed with the use of oil-free, dry nitrogen NF.

**5.1.12.3.8\* Verifier Piping Purity Test.** For each medical gas system, the purity of the piping system shall be verified in accordance with 5.1.12.3.8.

**5.1.12.3.8.1** These tests shall be performed with oil-free, dry nitrogen NF or the system gas.

**5.1.12.3.8.2** The outlet most remote from the source shall be tested for total non-methane hydrocarbons and compared to the source gas.

**5.1.12.3.8.3** If the system gas is used as the source gas, it shall be tested at the source equipment.

**5.1.12.3.8.4** The difference between the two tests shall in no case exceed 5 ppm of total non-methane hydrocarbons.

**5.1.12.3.8.5** The difference between the two tests shall in no case exceed 5 ppm halogenated hydrocarbons.

**5.1.12.3.8.6** The moisture concentration of the outlet test shall not exceed 500 ppm or an equivalent pressure dew point of -12°C (10°F) at a gauge pressure of 345 kPa (50 psi).

#### 5.1.12.3.9 Final Tie-In Test.

**5.1.12.3.9.1** Prior to the connection of any work or any extension or addition to an existing piping system, the tests in 5.1.12.3.1 through 5.1.12.3.8 shall be successfully performed on the new work.

**5.1.12.3.9.2** Each joint in the final connection between the new work and the existing system shall be leak-tested with the gas of system designation at the normal operating pressure by means of a leak detectant that is safe for use with oxygen and does not contain ammonia.

**5.1.12.3.9.3** Vacuum joints shall be tested using an ultrasonic leak detector or other means that will allow detection of leaks in an active vacuum system.

**5.1.12.3.9.4** For pressure gases, immediately after the final brazed connection is made and leak-tested, an outlet in the new piping and an outlet in the existing piping that are immediately downstream from the point or area of intrusion shall be purged in accordance with the applicable requirements of 5.1.12.3.6.

**5.1.12.3.9.5** Before the new work is used for patient care, positive pressure gases shall be tested for operational pressure and gas concentration in accordance with 5.1.12.3.10 and 5.1.12.3.11.

**5.1.12.3.9.6** Permanent records of these tests shall be maintained in accordance with 5.1.14.4.

**5.1.12.3.10 Operational Pressure Test.** Operational pressure tests shall be performed at each station outlet/inlet or terminal where the user makes connections and disconnections.

**5.1.12.3.10.1** Tests shall be performed with the gas of system designation or the operating vacuum.

**5.1.12.3.10.2** All gas outlets with a gauge pressure of 345 kPa (50 psi), including, but not limited to, oxygen, nitrous oxide, medical air, and carbon dioxide, shall deliver 100 SLPM (3.5 SCFM) with a pressure drop of not more than 35 kPa (5 psi) and static pressure of 345 kPa to 380 kPa (50 psi to 55 psi).

**5.1.12.3.10.3** Support gas outlets shall deliver 140 SLPM (5.0 SCFM) with a pressure drop of not more than 35 kPa (5 psi) gauge and static pressure of 1100 kPa to 1275 kPa (160 psi to 185 psi) gauge.



**5.1.12.3.10.4** Medical-surgical vacuum inlets shall draw 85 NI/min (3 SCFM) without reducing the vacuum pressure below 300 mm (12 in.) gauge HgV at any adjacent station inlet.

**5.1.12.3.10.5** Oxygen and medical air outlets serving critical care areas shall allow a transient flow rate of 170 SLPM (6 SCFM) for 3 seconds.

**5.1.12.3.11 Medical Gas Concentration Test.** After purging each system with the gas of system designation, the following shall be performed:

- (1) Each pressure gas source and outlet shall be analyzed for concentration of gas, by volume.
- (2) Analysis shall be conducted with instruments designed to measure the specific gas dispensed.
- (3)\*Allowable concentrations shall be as indicated in Table 5.1.12.3.11.

**Table 5.1.12.3.11 Gas Concentrations**

Medical Gas	Concentration
Oxygen	≥99% oxygen
Nitrous oxide	≥99% nitrous oxide
Nitrogen	≤1% oxygen or ≥99% nitrogen
Medical air	19.5%–23.5% oxygen
Other gases	As specified by ±1%, unless otherwise specified

**5.1.12.3.12 Medical Air Purity Test for Compressor Sources.**

**5.1.12.3.12.1** The medical air source shall be analyzed for concentration of contaminants by volume prior to the source valve being opened.

**5.1.12.3.12.2** A sample(s) shall be taken for the air system test at the system sample port.

**5.1.12.3.12.3** The test results shall not exceed the parameters in Table 5.1.12.3.12.3.

**Table 5.1.12.3.12.3 Contaminant Parameters for Medical Air**

Parameter	Limit Value
Pressure dew point	2°C (35°F)
Carbon monoxide	10 ppm
Carbon dioxide	500 ppm
Gaseous hydrocarbons	25 ppm (as methane)
Halogenated hydrocarbons	2 ppm

**5.1.12.3.13 Labeling.** The presence and correctness of labeling required by this code for all components (e.g., station outlets/inlets, shutoff valves, and alarm panels) shall be verified.

**5.1.12.3.14 Source Equipment Verification.**

**5.1.12.3.14.1 General.** Source equipment verification shall be performed following the installation of the interconnecting pipelines, accessories, and source equipment.

**5.1.12.3.14.2 Gas Supply Sources.**

(A) The system apparatus shall be tested for proper function, including the changeover from primary to secondary

supply (with its changeover signal) and the operation of the reserve (with its reserve-in-use signal), before the system is put into service.

(B) If the system has an actuating switch and signal to monitor the contents of the reserve, its function shall be tested before the system is put into service.

(C) If the system has an actuating switch and signal to monitor the pressure of the reserve unit, its function shall be tested before the system is put into service.

(D) Testing of the bulk supply signal and the master signal panel installations shall be arranged with the owner or the organization responsible for the operation and maintenance of the supply system for the testing of the bulk supply signals to ensure proper identification and activation of the master signal panels so that the facility can monitor the status of that supply system.

(E) The tests required in 5.1.12.3.14.2(D) shall also be conducted when the storage units are changed or replaced.

**5.1.12.3.14.3 Medical Air Compressor Systems.**

(A) Tests of the medical air compressor system shall include the purity test for air quality, and the test of the alarm sensors after calibration and setup per the manufacturer’s instructions, as well as lead-lag controls.

(B) Tests shall be conducted at the sample port of the medical air system.

(C) The operation of the system control sensors, such as dew point, air temperature, and all other air quality monitoring sensors and controls, shall be checked for proper operation and function before the system is put into service.

(D) The quality of medical air as delivered by the compressor air supply shall be verified after installation of new components prior to use by patients.

(E) The air quality tests in 5.1.12.3.14.3(D) shall be conducted after the medical air source system has been operating normally but with the source valve closed under a simulated load for an elapsed time of at least 12 hours.

(F) The aggregate run time on the compressors shall not be used to determine the elapsed time.

(G) Loading shall be simulated by continuously venting air at approximately 25 percent of the rated system capacity.

(H) A demand of approximately 25 percent of the rated compressor capacity shall be created to cause the compressors to cycle on and off continuously and the dryers to operate for the 24-hour period.

**5.1.12.3.14.4 Proportioning Systems for Medical Air USP.**

(A) The system apparatus shall be tested for proper function, including the changeover from primary to secondary (if applicable) and operation of the reserve, before the system is put into service.

(B) Tests shall include the purity of the air quality and test of the alarm sensors after calibration and setup per the manufacturer’s instructions.

(C) Tests shall be conducted at the sample port of the proportioning system.

(D) The operation of the control sensors and all quality monitoring sensors and controls shall be checked for proper operation and function before the system is put into service.

**5.1.12.3.14.5 Medical–Surgical Vacuum Systems.** The proper functioning of the medical–surgical vacuum source system(s) shall be tested before it is put into service.

**5.1.13 Category 1 Support Gases.**

**5.1.13.1\* Nature of Hazards Support Gas System.**

**5.1.13.2 Sources.** Requirements for support gas sources shall be in accordance with the following:

- (1) Paragraphs 5.1.3.1 through 5.1.3.5 for nitrogen
- (2) Paragraph 5.1.3.9 for instrument air

**5.1.13.3 Valves.** Requirements for support gas valves shall be in accordance with 5.1.4.1 through 5.1.4.10.

**5.1.13.4 Outlets.**

**5.1.13.4.1** Requirements for nitrogen support gas outlets shall be in accordance with 5.1.5.1, 5.1.5.2, 5.1.5.4 through 5.1.5.8, 5.1.5.11, and 5.1.5.13 through 5.1.5.15.

**5.1.13.4.2** Requirements for other support gas outlets shall be in accordance with 5.1.5.1, 5.1.5.2, 5.1.5.4, 5.1.5.5, 5.1.5.7, 5.1.5.8, 5.1.5.11, and 5.1.5.13 through 5.1.5.15.

**5.1.13.5 Manufactured Assemblies.** Requirements for support gases in manufactured assemblies shall be in accordance with 5.1.6.1 through 5.1.6.9.

**5.1.13.6 Pressure Indicators.** Requirements for support gas pressure indicators shall be in accordance with 5.1.8.1.1 through 5.1.8.1.4, 5.1.8.1.6, 5.1.8.1.7, and 5.1.8.2.

**5.1.13.7 Warning Systems.**

**5.1.13.7.1** General requirements for support gas warning systems shall be in accordance with 5.1.9.1.

**5.1.13.7.2** Master alarm requirements for support gas shall be in accordance with 5.1.9.2.

**5.1.13.7.3** Area alarm requirements for support gas shall be in accordance with 5.1.9.3.

**5.1.13.7.4** Local alarm requirements for support gas shall be in accordance with 5.1.9.4.

**5.1.13.8 Distribution.** Requirements for support gas piping distribution shall be in accordance with 5.1.10.1, 5.1.10.3, 5.1.10.4, 5.1.10.4.1 through 5.1.10.4.6, 5.1.10.9, 5.1.10.9(1), 5.1.10.9(2), 5.1.10.9(3), and 5.1.10.11.

**5.1.13.9 Labeling and Identification.** Requirements for support gas labeling shall be in accordance with 5.1.11.1 through 5.1.11.4.

**5.1.13.10 Performance Testing.** Requirements for support gas performance testing shall be in accordance with 5.1.12, with the following exceptions:

- (1) The piping purity test (*see 5.1.12.3.8*) shall be permitted to be omitted.
- (2) The medical gas concentration test (*see 5.1.12.3.11*) shall be permitted to be omitted.

**5.1.14\* Category 1 Operation and Management.**

**5.1.14.1 Special Precautions — Patient Gas, Vacuum, WAGD, and Medical Support Gas Systems.**

**5.1.14.1.1\*** Piping systems shall not be used for the distribution of flammable anesthetic gases.

**5.1.14.1.2** Piping systems shall not be used as a grounding electrode.

**5.1.14.1.3\*** Liquid or debris shall not be introduced into the medical–surgical vacuum or WAGD systems for disposal.

**5.1.14.1.4\*** The medical–surgical vacuum and WAGD systems shall not be used for nonmedical applications (e.g., vacuum steam condensate return).

**5.1.14.2 Maintenance of Medical Gas, Vacuum, WAGD, and Medical Support Gas Systems.**

**5.1.14.2.1\* General.** Health care facilities with installed medical gas, vacuum, WAGD, or medical support gas systems, or combinations thereof, shall develop and document periodic maintenance programs for these systems and their subcomponents as appropriate to the equipment installed.

**5.1.14.2.2 Maintenance Programs.**

**5.1.14.2.2.1 Inventories.** Inventories of medical gas, vacuum, WAGD, and medical support gas systems shall include at least all source subsystems, control valves, alarms, manufactured assemblies containing patient gases, and outlets.

**5.1.14.2.2.2\* Inspection Schedules.** Scheduled inspections for equipment and procedures shall be established through the risk assessment of the facility and developed with consideration of the original equipment manufacturer recommendations and other recommendations as required by the authority having jurisdiction.

**5.1.14.2.2.3 Inspection Procedures.** The facility shall be permitted to use any inspection procedure(s) or testing methods established through its own risk assessment.

**5.1.14.2.2.4 Maintenance Schedules.** Scheduled maintenance for equipment and procedures shall be established through the risk assessment of the facility and developed with consideration of the original equipment manufacturer recommendations and other recommendations as required by the authority having jurisdiction.

**5.1.14.2.2.5 Qualifications.** Persons maintaining these systems shall be qualified to perform these operations. Appropriate qualification shall be demonstrated by any of the following:

- (1) Training and certification through the health care facility by which such persons are employed to work with specific equipment as installed in that facility
- (2) Credentialing to the requirements of ASSE 6040, *Professional Qualification Standard for Medical Gas Maintenance Personnel*
- (3) Credentialing to the requirements of ASSE 6030, *Professional Qualification Standard for Medical Gas Systems Verifiers*

**5.1.14.2.3 Inspection and Testing Operations.**

**5.1.14.2.3.1 General.** The elements in 5.1.14.2.2.2 through 5.1.15 shall be inspected or tested as part of the maintenance program as follows:

- (1)\*Medical air source, as follows:
  - (a) Room temperature
  - (b) Shaft seal condition
  - (c) Filter condition
  - (d) Presence of hydrocarbons
  - (e) Room ventilation
  - (f) Water quality, if so equipped
  - (g) Intake location
  - (h) Carbon monoxide monitor calibration
  - (i) Air purity
  - (j) Dew point

- (2)\*Medical vacuum source — exhaust location
- (3) WAGD source — exhaust location
- (4)\*Instrument air source — filter condition
- (5)\*Manifold sources (including systems complying with 5.1.3.5.10, 5.1.3.5.11, 5.1.3.5.12, and 5.1.3.5.13), as follows:
  - (a) Ventilation
  - (b) Enclosure labeling
- (6) Bulk cryogenic liquid source inspected in accordance with NFPA 55, *Compressed Gases and Cryogenic Fluids Code*
- (7) Final line regulation for all positive pressure systems — delivery pressure
- (8)\*Valves — labeling
- (9)\*Alarms and warning systems — lamp and audio operation
- (10) Alarms and warning systems, as follows:
  - (a) Master alarm signal operation
  - (b) Area alarm signal operation
  - (c) Local alarm signal operation
- (11)\*Station outlets/inlets, as follows:
  - (a) Flow
  - (b) Labeling
  - (c) Latching/delatching
  - (d) Leaks

**5.1.14.2.3.2 Manufactured Assemblies Employing Flexible Connection(s) Between the User Terminal and the Piping System.**

(A) Nonstationary booms and articulating assemblies, other than head walls utilizing flexible connectors, shall be tested for leaks, per manufacturer's recommendations, every 18 months or at a duration as determined by a risk assessment.

(B) The system pressure to nonstationary booms and articulating arms shall be maintained at operating pressure until each joint has been examined for leakage by effective means of leak detection that is safe for use with oxygen.

(C) Safe working condition of the flexible assemblies shall be confirmed.

(D) D.I.S.S. connectors internal to the boom and assemblies shall be checked for leakage.

(E) Leaks, if any, shall be repaired (if permitted), or the components replaced (if required), and the equipment retested prior to placing the equipment back into service.

(F) Additional testing of nonstationary booms or articulating arms shall be performed at intervals defined by documented performance data.

**5.1.14.3 Medical Gas and Vacuum Systems Information and Warning Signs.**

**5.1.14.3.1** The gas content of medical gas and vacuum piping systems shall be labeled in accordance with 5.1.11.1.

**5.1.14.3.2** Labels for shutoff valves shall be in accordance with 5.1.11.2 and updated when modifications are made changing the areas served.

**5.1.14.4 Medical Gas and Vacuum Systems Maintenance and Record Keeping.** See B.5.2.

**5.1.14.4.1** Permanent records of all tests required by 5.1.12.3.1 through 5.1.12.3.14 shall be maintained in the organization's files.

**5.1.14.4.2** The supplier of the bulk cryogenic liquid system shall, upon request, provide documentation of vaporizer(s) sizing criteria to the facility.

**5.1.14.4.3** An annual review of bulk system capacity shall be conducted to ensure the source system has sufficient capacity.

**5.1.14.4.4** Central supply systems for nonflammable medical gases shall conform to the following:

- (1) They shall be inspected annually.
- (2) They shall be maintained by a qualified representative of the equipment owner.
- (3) A record of the annual inspection shall be available for review by the authority having jurisdiction.

**5.1.14.4.5** A periodic testing procedure for nonflammable medical gas and vacuum and related alarm systems shall be implemented.

**5.1.14.4.6** Whenever modifications are made that breach the pipeline, any necessary installer and verification test specified in 5.1.12 shall be conducted on the downstream portions of the medical gas piping system.

**5.1.14.4.7** Procedures, as specified, shall be established for the following:

- (1) Maintenance program for the medical air compressor supply system in accordance with the manufacturer's recommendations
- (2) Facility testing and calibration procedure that ensures carbon monoxide monitors are calibrated at least annually or more often if recommended by the manufacturer
- (3) Maintenance program for both the medical-surgical vacuum piping system and the secondary equipment attached to medical-surgical vacuum station inlets to ensure the continued good performance of the entire medical-surgical vacuum system
- (4) Maintenance program for the WAGD system to ensure performance

**5.1.14.4.8** Audible and visual alarm indicators shall meet the following requirements:

- (1) They shall be periodically tested to determine that they are functioning properly.
- (2) Records of the test shall be maintained until the next test is performed.

**5.1.14.4.9** Medical-surgical vacuum station inlet terminal performance, as required in 5.1.12.3.10.4, shall be tested as follows:

- (1) On a regular preventive maintenance schedule as determined by the facility maintenance staff
- (2) Based on flow of free air (NI/min or SCFM) into a station inlet while simultaneously checking the vacuum level

**5.1.15\* Category 1 Maintenance.** Facilities shall have a routine maintenance program for their piped medical gas and vacuum systems.

**5.2 Category 2 Piped Gas and Vacuum Systems.**

**5.2.1\* Applicability.** These requirements shall apply to health care facilities that qualify for Category 2 systems as referenced in Chapter 4.

**5.2.1.1** Section 5.2 through 5.2.12 shall apply to new health care facilities or facilities making changes that alter the piping.

**5.2.1.2** Subsection 5.2.13 through 5.2.14 shall apply to existing health care facilities.

**5.2.1.3** Subsection 5.2.11 through 5.2.12 shall apply to new and existing health care facilities.

**5.2.2 Nature of Hazards of Gas and Vacuum Systems.** The requirement of 5.1.2 shall apply to the nature of hazards of gas and vacuum systems.

**5.2.3 Category 2 Sources.**

**5.2.3.1 Central Supply System Identification and Labeling.** Category 2 systems shall comply with 5.1.3.1.

**5.2.3.2 Central Supply Operations.** Category 2 systems shall comply with 5.1.3.2.

**5.2.3.3 Central Supply System Locations.** Category 2 systems shall comply with 5.1.3.3.

**5.2.3.4 Central Supply Systems.** Category 2 systems shall comply with 5.1.3.5.

**5.2.3.5 Category 2 Medical Air Supply Systems.** Category 2 systems shall comply with 5.1.3.6, except as follows:

- (1) Medical air compressors, dryers, aftercoolers, filters, and regulators shall be permitted to be simplex.
- (2) The facility staff shall develop their emergency plan to deal with the loss of medical air.

**5.2.3.6 Category 2 Medical-Surgical Vacuum.** Category 2 systems shall comply with 5.1.3.7, except as follows:

- (1) Medical-surgical vacuum systems shall be permitted to be simplex.
- (2) The facility staff shall develop their emergency plan to deal with the loss of medical-surgical vacuum.

**5.2.3.7 Category 2 WAGD.** Category 2 systems shall comply with 5.1.3.8, except as follows:

- (1) Medical WAGD pumps shall be permitted to be simplex.
- (2) The facility staff shall develop their emergency plan to deal with the loss of WAGD.

**5.2.3.8 Instrument Air Supply Systems.** Category 2 systems shall comply with 5.1.3.9.

**5.2.4 Valves.** Category 2 systems shall comply with 5.1.4.

**5.2.5 Station Outlets and Inlets.** Category 2 systems shall comply with 5.1.5.

**5.2.6 Manufactured Assemblies.** Category 2 systems shall comply with 5.1.6.

**5.2.7 Surface-Mounted Medical Gas Rails.** Category 2 systems shall comply with 5.1.7.

**5.2.8 Pressure and Vacuum Indicators.** Category 2 systems shall comply with 5.1.8.

**5.2.9 Warning Systems (Category 2).** Warning systems associated with Category 2 systems shall provide the master, area, and local alarm functions of a Category 1 system as required in 5.1.9, except as follows:

- (1) Warning systems shall be permitted to be a single alarm panel.
- (2) The alarm panel shall be located in an area of continuous surveillance while the facility is in operation.
- (3) Pressure and vacuum switches/sensors shall be mounted at the source equipment with a pressure indicator at the master alarm panel.

**5.2.10 Category 2 Distribution.** Level 2 systems shall comply with 5.1.10.

**5.2.11 Labeling and Identification.** Category 2 systems shall comply with 5.1.11.

**5.2.12 Performance Criteria and Testing — Category 2 (Gas, Medical-Surgical Vacuum, and WAGD).** Category 2 systems shall comply with 5.1.12.

**5.2.13 Category 2 Operation and Management.** Category 2 systems shall comply with 5.1.14.

**5.2.14\* Category 2 Maintenance.** Facilities shall have a routine maintenance program for their piped medical gas and vacuum systems.

**5.3\* Category 3 Piped Gas and Vacuum Systems.**

**5.3.1\* Applicability.**

**5.3.1.1** These requirements shall apply to health care facilities that qualify to install Category 3 systems as defined in Chapter 4.

**5.3.1.1.1** Subsection 5.3.2 through 5.3.11.3 and 5.3.12.3 shall apply to new health care facilities or facilities making changes that alter the piping.

**5.3.1.1.2** Paragraph 5.3.12.2 and 5.3.13.4 shall apply to existing health care facilities.

**5.3.1.1.3** Paragraph 5.3.1.1, 5.3.2, 5.3.12.1, and 5.3.13.3 shall apply to new and existing health care facilities.

**5.3.1.1.4** A single Category 3 medical gas source system shall not supply more than two adjoining single treatment facilities.

**5.3.1.2** Category 3 medical gas systems shall only use oxygen and nitrous oxide.

**5.3.1.3** Category 3 gas-powered device supply systems shall use compressed air and nitrogen.

**5.3.1.4** Category 3 vacuum and scavenging systems shall be of either the wet or dry type.

**5.3.1.5\*** Deep sedation and general anesthesia shall not be permitted to be administered when using a Category 3 medical gas system.

**5.3.1.6** An existing Category 3 system that is not in strict compliance with the requirements of this code shall be permitted to continue in use as long as the authority having jurisdiction has determined that such use does not constitute a distinct hazard to life.

**5.3.2 Nature of Hazards of Gas and Vacuum Systems.** Potential fire and explosion hazards associated with Category 3 gas and vacuum systems shall be considered in the design, installation, testing, operation, and maintenance of the systems.

**5.3.3 Seismic Restraint.** Where required, Category 3 gas and vacuum equipment and piping shall be seismically restrained against earthquakes in accordance with the applicable building code.

**5.3.4 Protection Against Cross-Connections.** All connections within Category 3 medical gas (oxygen and nitrous oxide) shall be gas-specific to prevent cross-connections with other piping systems, including vacuum, water, and drive gas.

**5.3.5 Systems with Nonstandard Operating Pressures.** Station outlets and piped outlets for Category 3 medical gas and gas-powered dispensing devices having nonstandard operating pressures shall comply with the following additional requirements:

- (1) Be gas-specific.
- (2) Be pressure-specific where a single gas is piped at more than one operating pressure.
- (3) Be a D.I.S.S connection if operated at a gauge pressure in excess of 550 kPa (80 psi).
- (4) Be designed to prevent the removal of the adapter until the pressure has been relieved, if operated at a gauge pressure between 1380 kPa and 2070 kPa (200 psi and 300 psi).

**5.3.6 Category 3 Medical Gas Supply Systems (Oxygen and Nitrous Oxide).**

**5.3.6.1 Installer Qualifications.**

**5.3.6.1.1** Installers of Category 3 medical gas sources (i.e., oxygen and nitrous oxide) where the total of all gases in cylinders or containers, except nitrogen, connected and in storage at one time does not exceed 85 m<sup>3</sup> (3000 ft<sup>3</sup>) at standard temperature and pressure (STP), or 142 m<sup>3</sup> (5000 ft<sup>3</sup>) (STP) if oxygen is stored in a DOT Specification 4L (cryogenic liquid) container shall be certified in accordance with ASSE 6010, *Professional Qualification Standard for Medical Gas Systems Installers*.

**5.3.6.1.2** Installers of Category 3 medical gas sources (i.e., oxygen and nitrous oxide) where the total of all gases exceeds the limits specified in 5.3.6.1.1, shall be qualified in accordance with CGA M-1, *Guide for Medical Gas Installations at Consumer Sites*.

**5.3.6.1.3** The installers of Category 3 medical gas piped distribution systems (i.e., oxygen and nitrous oxide), regardless of source equipment size, shall be certified in accordance with ASSE 6010, *Professional Qualification Standard for Medical Gas Systems Installers*.

**5.3.6.1.4** Installers of medical gas (i.e., oxygen and nitrous oxide) shall not use their certification to oversee installation by non-certified personnel.

**5.3.6.2 Category 3 Medical Gas Distribution Piping (Oxygen and Nitrous Oxide).**

**5.3.6.2.1** Tubes shall be hard-drawn seamless copper in accordance with ASTM B 819, *Standard Specification for Seamless Copper Tube for Medical Gas Systems, Medical Gas Tube, Not Less Than Type L*.

**5.3.6.2.2** Tubes, valves, fittings, station outlets, and other piping components shall have been cleaned for oxygen by the manufacturer prior to installation in accordance with CGA G-4.1, *Cleaning Equipment for Oxygen Service*, except that fittings shall be permitted to be cleaned by a supplier or agency other than the manufacturer.

**5.3.6.2.3** Joints for tubes, turns, offsets, and other changes in direction shall be made with brazed wrought copper capillary fittings complying with one of the following:

- (1) ASME B16.22, *Wrought Copper and Copper Alloy Solder-Joint Pressure Fittings*
- (2) ANSI/ASME B16.50, *Wrought Copper and Copper Alloy Braze-Joint Pressure Fittings*
- (3) ASME B16.22, with socket depths equal to or greater than brazed joint pressure fittings in accordance with ANSI/ASME B16.50

**5.3.6.2.4** Cast copper alloy fittings shall not be used with field-brazed joints.

**5.3.6.2.5** Threaded joints in Category 3 medical gas systems (oxygen and nitrous oxide) shall comply with the following:

- (1) They shall be limited to connections to pressure indicators, alarm devices, and source equipment.
- (2) They shall have tapered threads complying with ASME B1.20.1, *Pipe Threads, General Purpose, Inch*.
- (3) They shall be made up with polytetrafluoroethylene (such as Teflon™) tape or other thread sealant recommended for oxygen service, with the sealant applied to the male threads only.

**5.3.6.2.6** The following joints shall be prohibited in Category 3 medical gas piping (oxygen and nitrous oxide):

- (1) Flared and compression connections, including connections to station outlets, alarm devices, and other components
- (2) Push-lock connections
- (3) Straight-threaded connections, including unions

**5.3.6.2.7** Special-purpose fittings permitted in Category 1 medical gas piping systems shall be permitted to be used in Category 3 medical gas piping systems.

**5.3.6.3 Qualification of Brazing Procedures and Brazing.**

**5.3.6.3.1** Brazing procedures and brazer performance for the installation of Category 3 medical gas piping shall meet the same qualifications as Category 1 piping in accordance with either Section IX, "Welding and Brazing Qualifications," of the ASME *Boiler and Pressure Vessel Code*, or AWS B2.2, *Standard for Brazing Procedure and Performance Qualification*, both as modified by 5.3.6.3.2 through 5.3.6.3.7.

**5.3.6.3.2** Brazers shall be qualified by visual examination of the test coupons followed by sectioning.

**5.3.6.3.3** The brazing procedure specification shall address cleaning, joint clearance, overlap, internal purge gas, purge gas flow rate, and filler metal.

**5.3.6.3.4** The brazing procedure qualification record and the record of brazer performance qualification shall document the filler metal used, cleaning, joint clearance, overlap, internal purge gas and flow rate during brazing of the coupon, and absence of internal oxidation in the completed coupon.

**5.3.6.3.5** Brazing procedures qualified by a technically competent group or agency shall be permitted under the following conditions:

- (1) The brazing procedure specification and the procedure qualification record meet the requirements of this code.
- (2) The employer obtains a copy of both the brazing procedure specification and the supporting qualification record from the group or agency and signs and dates these records, thereby accepting responsibility for the qualifications that were performed by the group or agency.
- (3) The employer qualifies at least one brazer following each brazing procedure specification used.

**5.3.6.3.6** An employer shall be permitted to accept brazer qualification records of a previous employer under the following conditions:

- (1) The brazer has been qualified following the same procedure that the new employer uses, or an equivalent procedure.
- (2) The new employer obtains a copy of the record of brazer performance qualification tests from the previous employer and signs and dates these records, thereby accepting responsibility for the qualifications performed by the previous employer.

**5.3.6.3.7** Performance qualifications of brazers shall remain in effect indefinitely, unless the brazer does not braze with the qualified procedure for a period exceeding 6 months or there is a specific reason to question the ability of the brazer.

**5.3.6.4 Brazed Joints.**

**5.3.6.4.1** Brazed tube joints shall be of the socket type.

**5.3.6.4.2** Brazed joints shall be made using a brazing alloy that exhibits a melting temperature in excess of 538°C (1000°F) to retain the integrity of the piping system in the event of fire exposure.

**5.3.6.4.3** Filler metals shall bond with, and be metallurgically compatible with, the base metal being joined.

**5.3.6.4.4** Filler metals shall comply with ANSI/AWS A5.8, *Specification for Filler Metals for Brazing and Braze Welding*.

**5.3.6.4.5** Copper-to-copper joints shall be brazed using a copper-phosphorus or copper-phosphorus-silver brazing filler metal (BCuP series) without flux.

**5.3.6.4.6** Joints to be brazed in place shall be accessible for necessary preparation, assembly, heating, filler application, cooling, cleaning, and inspection.

**5.3.6.5 Cutting Tube Ends.**

**5.3.6.5.1** Tube ends shall be cut square using a sharp tubing cutter to avoid deforming the tube.

**5.3.6.5.2** The cutting wheels on tubing cutters shall be free from grease, oil, or other lubricant not recommended for oxygen service.

**5.3.6.5.3** The cut ends of the tube shall be rolled smooth or deburred with a sharp, clean deburring tool, taking care to prevent chips from entering the tube.

**5.3.6.6 Cleaning Joints for Brazing.**

**5.3.6.6.1** The interior surfaces of tubes, fittings, and other components that are cleaned for oxygen service shall be stored and handled to avoid contamination prior to assembly and brazing.

**5.3.6.6.2** The exterior surfaces of tube ends shall be cleaned prior to brazing to remove any oxides and surface dirt and to roughen the surfaces to prepare them for brazing.

**5.3.6.6.3** Nonabrasive pads shall be used to clean the exterior surfaces of tube ends.

**5.3.6.6.4** The use of steel wool, sand cloth, or wire brushes shall be prohibited.

**5.3.6.6.5** The cleaning process shall not result in grooving the surfaces to be joined.

**5.3.6.6.6** After being abraded, the surfaces shall be wiped using a clean, lint-free white cloth.

**5.3.6.6.7** Tubes, fittings, valves, and other components shall be visually examined internally before being joined to verify that they have not become contaminated for oxygen service and that they are free of obstructions or debris.

**5.3.6.6.8** Material that has become contaminated internally and is not clean for oxygen service shall not be installed.

**5.3.6.6.9** Joints shall be brazed within 8 hours after being cleaned for brazing.

**5.3.6.7 Brazing Dissimilar Metals.**

**5.3.6.7.1** Flux shall only be used when brazing dissimilar metals, such as copper and bronze or brass, using a silver brazing filler metal (BAg series).

**5.3.6.7.2** Cast metals shall not be field-brazed.

**5.3.6.7.3** Surfaces shall be cleaned for brazing in accordance with 5.3.6.6.

**5.3.6.7.4** Flux shall be applied sparingly to minimize contamination of the inside of the tube with flux.

**5.3.6.7.5** The flux shall be applied and worked over the cleaned surfaces to be brazed using a stiff bristle brush to ensure complete coverage and wetting of the surfaces with flux.

**5.3.6.7.6** Where possible, short sections of copper tube shall be brazed onto the non-copper component, and the interior of the subassembly shall be cleaned of flux prior to installation in the system.

**5.3.6.7.7** On joints DN20 (NPS ¾) (¾ in. O.D.) size and smaller, flux-coated brazing rods shall be permitted to be used in lieu of applying flux to the surfaces to be joined.

**5.3.6.8\* Nitrogen Purge.**

**5.3.6.8.1** While being brazed, joints shall be continuously purged with oil-free, dry nitrogen NF to prevent the formation of copper oxide on the inside surface of the joint.

**5.3.6.8.2** The source of the nitrogen purge gas shall be monitored, and the installer shall be audibly alerted when the content is low.

**5.3.6.8.3** The nitrogen purge gas flow rate shall not be high enough to produce a positive pressure in the piping system.

**5.3.6.8.4** The nitrogen purge gas flow shall be controlled by the use of both a pressure regulator and a flowmeter, or a combination thereof.

**5.3.6.8.5** Pressure regulators alone shall not be used to control nitrogen purge gas flow rates.

**5.3.6.8.6** During and after installation, openings in the piping system shall be kept capped or plugged to maintain a nitrogen atmosphere within the piping and to prevent debris or other contaminants from entering the system.

**5.3.6.8.7** While a joint is being brazed, a discharge opening shall be provided on the opposite side of the joint from where the nitrogen purge gas is being introduced.

**5.3.6.8.8** The flow of nitrogen purge gas shall be maintained until the joint is cool to the touch.

**5.3.6.8.9** After the joint has cooled, the purge discharge opening shall be plugged or capped to prevent contamination of the inside of the tube and maintain the nitrogen atmosphere within the piping system.

**5.3.6.9 Assembling and Heating Brazed Joints.**

**5.3.6.9.1** Tube ends shall be inserted either fully into the depth of the fitting socket or to a mechanically limited depth that is not less than the minimum cup depth (overlap) specified in ANSI/ASME B16.50, *Standard Specification for Wrought Copper and Copper Alloy Braze-Joint Pressure Fittings*.

**5.3.6.9.2** Where flux is permitted, joints shall be heated slowly until the flux has liquefied.

**5.3.6.9.3** After flux has liquefied, or where flux is not permitted to be used, the joint shall be heated quickly to the brazing temperature, taking care not to overheat the joint.

**5.3.6.9.4** Techniques for heating joints, applying the brazing filler metal, and making the horizontal, vertical, and large-diameter joints shall be as described in sections on applying heat and brazing horizontal and vertical joints in Chapter VII, "Brazed Joints," in the CDA *Copper Tube Handbook*.

**5.3.6.10 Inspection of Brazed Joints.**

**5.3.6.10.1** After brazing, the outside of all joints shall be cleaned by washing with water and a wire brush to remove any residue and allow clear visual inspection of the joint.

**5.3.6.10.2** Where flux has been used, the wash water shall be hot.

**5.3.6.10.3** Each joint shall be visually inspected after cleaning the outside surfaces.

**5.3.6.10.4** Joints exhibiting the following conditions shall not be permitted:

- (1) Flux or flux residue (when flux or flux-coated BAg rods are used with dissimilar metals)
- (2) Base metal melting or erosion
- (3) Unmelted filler metal
- (4) Failure of the filler metal to be clearly visible all the way around the joint at the interface between the socket and the tube
- (5) Cracks in the tube or component
- (6) Cracks in the filler metal
- (7) Failure of the joint to hold the test pressure under the installer-performed initial pressure test (*see 5.3.6.23.2.3*) and standing pressure test (*see 5.3.6.23.2.6*)

**5.3.6.10.5** Joints that are identified as defective under conditions specified in 5.3.6.10.4(2) or (5) shall be replaced.

**5.3.6.10.6** Joints that are found to be defective under conditions specified in 5.3.6.10.4(1), (3), (4), (6), or (7) shall be permitted to be repaired, except that no joint shall be reheated more than once before being replaced.

**5.3.6.11 Installation of Category 3 Medical Gas Piping (Oxygen and Nitrous Oxide).**

**5.3.6.11.1 Pipe Sizing.** Piping systems shall be designed and sized to deliver the required flow rates at the utilization pressures.

**5.3.6.11.2\* Minimum Pipe Sizes.** The minimum sizes of Category 3 oxygen and nitrous oxide piping shall be as follows:

- (1) Category 3 oxygen piping systems shall be not less than DN10 (NPS 3/8 in.) (1/2 in. O.D.) size.
- (2) Category 3 nitrous oxide piping systems shall be not less than DN8 (NPS 1/4 in.) (3/8 in. O.D.) size.

**5.3.6.11.3 Location of Piping.** Oxygen and nitrous oxide piping shall not be located where subject to contact with oil.

**5.3.6.11.4 Protection of Piping.**

**5.3.6.11.4.1** Piping shall be protected against freezing, corrosion, and physical damage.

**5.3.6.11.4.2** Piping exposed in corridors and other locations where subject to physical damage from the movement of carts, stretchers, beds, portable equipment, or vehicles shall be protected.

**5.3.6.12 Pipe Support.**

**5.3.6.12.1** Piping shall be supported from the building structure.

**5.3.6.12.2** Hangers and supports shall comply with and be installed in accordance with MSS SP-58, *Pipe Hangers and Supports — Materials, Design, Manufacture, Selection, Application, and Installation*.

**5.3.6.12.3** Hangers and supports for copper tube shall be sized for copper tube.

**5.3.6.12.4** In potentially damp locations, copper tube hangers and supports that are in contact with the tube shall be plastic-coated or otherwise electrically insulated from the tube.

**5.3.6.12.5** The maximum support spacing for copper tube shall be in accordance with Table 5.3.6.12.5.

**Table 5.3.6.12.5 Maximum Copper Tube Support Spacing**

Pipe Size	Hanger Spacing	
	mm	ft
DN8 (NPS 1/4) (3/8 in. O.D.)	1520	5
DN10 (NPS 3/8) (1/2 in. O.D.)	1830	6
DN15 (NPS 1/2) (5/8 in. O.D.)	1830	6
DN20 (NPS 3/4) (7/8 in. O.D.)	2130	7
DN25 (NPS 1) (1 1/8 in. O.D.)	2440	8
DN32 (NPS 1 1/4) (1 3/8 in. O.D.)	2740	9
DN40 (NPS 1 1/2) (1 5/8 in. O.D.)	3050	10
and larger Vertical risers, all sizes, every floor, but not to exceed	4570	15

**5.3.6.13 Underground Piping Outside of Buildings.**

**5.3.6.13.1** Buried piping outside of buildings shall be installed below the local level of frost penetration.

**5.3.6.13.2** The installation procedure for underground piping shall prevent physical damage to the piping while being back-filled.

**5.3.6.13.3** If the underground piping is protected by a conduit, cover, or other enclosure, the following requirements shall be met:

- (1) Access during construction shall be provided at the joints for visual inspection and leak testing.
- (2) The conduit, cover, or enclosure shall be self-draining and not retain groundwater in prolonged contact with copper tubing.

**5.3.6.13.4** Buried piping that will be subject to surface loads shall be buried at a depth that will protect the piping or its enclosure, or both, from excessive stresses.

**5.3.6.13.5** The minimum backfill cover above the top of the piping or its enclosure shall be 900 mm (36 in.), except that the minimum cover shall be permitted to be reduced to 450 mm (18 in.) where there is no potential for damage from surface loads or surface conditions.

**5.3.6.13.6** Trenches shall be excavated so that the piping or its enclosure has firm, substantially continuous bearing on the bottom of the trench.

**5.3.6.13.7** Backfill shall be clean, free from material that can damage the pipe, and compacted.

**5.3.6.13.8** A continuous warning tape or marker shall be placed immediately above the piping or its enclosure to clearly identify the pipeline by specific name.

**5.3.6.13.9** A continuous warning means shall also be placed above the pipeline at approximately one-half the depth of burial.

**5.3.6.13.10** Where buried piping is extended into a building through a wall sleeve, the outdoor end of the sleeve shall be sealed watertight to prevent the entrance of groundwater into the building.

**5.3.6.14 Underground Piping Within Buildings.**

**5.3.6.14.1** The installation procedure for underground piping shall prevent physical damage to the piping while being backfilled.

**5.3.6.14.2** If the underground piping is protected by a conduit, cover, or other enclosure, access shall be provided at the joints during construction for visual inspection and leak testing.

**5.3.6.14.3** The piping shall be backfilled with clean sand or gravel.

**5.3.6.15 Piping Within Floor Slabs Prohibited.** Category 3 medical gas piping (oxygen and nitrous oxide) shall not be installed within floor slabs.

**5.3.6.16 Hose and Flexible Connectors.**

**5.3.6.16.1** Hose and flexible connectors, both metallic and nonmetallic, shall be no longer than necessary and shall not penetrate or be concealed in walls, floors, ceilings, or partitions.

**5.3.6.16.2** Hose and flexible connectors, metallic or nonmetallic, shall have a minimum burst gauge pressure of 6895 kPa (1000 psi).

**5.3.6.16.3** Medical gas hose and flexible connectors shall be oxygen compatible.

**5.3.6.16.4** Hose and flexible connectors shall be clearly identified as to the gas content.

**5.3.6.16.5** Hose and flexible connectors for Category 3 medical gases (oxygen and nitrous oxide) shall be gas-specific and not be permitted to conduct any other gas, gas mixture, or liquid.

**5.3.6.17\* Category 3 Medical Gas Station Outlets (Oxygen and Nitrous Oxide).**

**5.3.6.17.1\*** Each station outlet for Category 3 medical gases shall be gas-specific, whether the outlet connection is threaded or is a noninterchangeable quick coupler.

**5.3.6.17.2** Each station outlet shall consist of a primary and secondary valve (or assembly).

**5.3.6.17.3** Each secondary valve (or assembly) shall close automatically to stop the flow of gas when the primary valve (or assembly) is removed.

**5.3.6.18 Piped Outlets for Connection to Category 3 Medical Gas Dispensing Devices.**

**5.3.6.18.1** Piped outlets for connection to Category 3 medical gas dispensing devices shall be gas-specific.

**5.3.6.18.2** Piped outlets shall include a check valve and be capped until connected to the gas dispensing device.

**5.3.6.18.3** Where piped outlets are connected to gas dispensing devices by flexible tubing, the tubing shall have a minimum burst gauge pressure of 6895 kPa (1000 psi) and be rated for oxygen use.

**5.3.6.18.4** All connections between piped outlets and gas dispensing devices shall be gas-specific to prevent cross-connections.

**5.3.6.19 Emergency Shutoff Valves.**

**5.3.6.19.1\*** Where a central Category 3 medical gas (oxygen and nitrous oxide) supply is remote from a single treatment facility, the main supply line shall be provided with an emergency shutoff valve so located in the single treatment facility as to be accessible from all use-point locations in an emergency.

**5.3.6.19.2** Where a central Category 3 medical gas (oxygen and nitrous oxide) supply system supplies two treatment facilities, each facility shall be provided with an emergency shutoff valve so located in the treatment facility as to be accessible from all use-point locations in an emergency.

**5.3.6.19.3** Emergency shutoff valves shall be labeled to indicate the gas controlled and shall shut off only the gas to the treatment facility that they serve.

**5.3.6.19.4** A remotely activated shutoff valve at a supply manifold shall not be used for emergency shutoff. For clinical purposes, such a remote valve actuator shall not fail-closed in the event of a loss of electric power. Where remote actuators are the type that fail-open, it shall be mandatory that cylinder shutoff valves be closed whenever the system is not in use.

**5.3.6.20 Locations of Medical Gas Source Equipment (Oxygen and Nitrous Oxide).**

**5.3.6.20.1** Gas storage locations in facilities with Category 3 medical gas systems with a total of all gases in cylinders or containers, except nitrogen, connected and in storage at one time that does not exceed 85 m<sup>3</sup> (3000 ft<sup>3</sup>) at standard temperature and pressure (STP), or 142 m<sup>3</sup> (5000 ft<sup>3</sup>) (STP) if oxygen is stored in a DOT Specification 4L (cryogenic liquid) container shall comply with 5.3.6.20.3 through 5.3.6.20.12.

**5.3.6.20.2** Gas storage locations in facilities with Category 3 medical gas systems with a total of all gases in cylinders or containers exceeding quantities listed in 5.3.6.20.1 shall comply with 5.1.3.3.

**5.3.6.20.3** Enclosures shall serve no purpose other than to contain the medical gas source equipment (oxygen and nitrous oxide), except that nitrogen source equipment in 5.3.7.7 and compressed air cylinders in 5.3.7.6 shall be permitted in the enclosure.

**5.3.6.20.4** Storage of full or empty gas cylinders, or both, shall be permitted in the same enclosure.

**5.3.6.20.5** Air compressors, vacuum pumps, and other equipment shall not be located in enclosures for medical gas cylinders (oxygen and nitrous oxide source equipment).

**5.3.6.20.6** If enclosures are outdoors or remote from the treatment facilities that they serve, they shall be kept locked.

**5.3.6.20.7** Cylinders in use and in storage shall be prevented from reaching temperatures in excess of 54°C (130°F). Nitrous oxide cylinders shall be prevented from reaching temperatures lower than -7°C (20°F).

**5.3.6.20.8** Only gas cylinders, reusable shipping containers, and their accessories shall be permitted to be stored in rooms containing central supply systems or gas cylinders.



**5.3.6.20.9** No flammable materials, cylinders containing flammable gases, or containers containing flammable liquids shall be stored in rooms with gas cylinders.

**5.3.6.20.10** Indoor enclosures shall not communicate directly with medical gas (oxygen and nitrous oxide) use points or storage locations for oxidizers.

**5.3.6.20.11** Outdoor enclosures that are adjacent to a building wall shall be located such that the distance to any window or door of the adjacent building is greater than 3.05 m (10 ft).

**5.3.6.20.12** Enclosures for Category 3 medical gas source equipment shall be provided with doors or gates.

**5.3.6.21 Category 3 Medical Gas Source Equipment (Oxygen and Nitrous Oxide).**

**5.3.6.21.1** Mechanical means shall be provided to ensure that the medical gas source equipment is connected to the correct medical gas distribution piping system.

**5.3.6.21.2** Cylinder valve outlets for oxygen and nitrous oxide shall comply with CGA V-1, *Compressed Gas Association Standard for Compressed Gas Cylinder Valve Outlet and Inlet Connections*.

**5.3.6.21.3** Threaded connections to manifolds shall comply with CGA V-5, *Diameter-Index Safety System (Noninterchangeable Low Pressure Connections for Medical Gas Applications)*.

**5.3.6.21.4** A check valve shall be provided downstream of each pressure regulator.

**5.3.6.21.5** A pressure relief valve set at 50 percent above the normal line pressure shall be located downstream of the check valve in 5.3.6.21.4.

**5.3.6.21.6** Pressure relief valves shall be brass, bronze, or stainless steel and designed for oxygen service.

**5.3.6.21.7** Hose and flexible connectors shall have a gauge pressure rating not less than 6895 kPa (1000 psi).

**5.3.6.21.8** Materials used in central supply systems shall meet the following requirements:

- (1) In those portions of systems intended to handle oxygen at gauge pressures equal to or greater than 2413 kPa (350 psi), interconnecting hose shall contain no polymeric materials.
- (2) In those portions of systems intended to handle oxygen or nitrous oxide material, construction shall be compatible with oxygen under the temperatures and pressures to which the components can be exposed.
- (3) If potentially exposed to cryogenic temperatures, materials shall be designed for low temperature service.
- (4) If intended for outdoor installation, materials shall be installed per the manufacturer's requirements.

**5.3.6.21.9** Flexible connectors of other than all-metal construction that connect manifolds to the gas distribution piping shall not exceed 1.52 m (5 ft) in length and shall not penetrate walls, floors, ceilings, or partitions.

**5.3.6.21.10** Medical gas source equipment that serves one or two treatment facilities shall include two banks of one or more cylinders of oxygen and (if used) two banks of one or more cylinders of nitrous oxygen, each bank containing at least an average day's supply.

**5.3.6.21.11** The two banks of each medical gas source shall be manifolded so that either bank can supply its distribution piping system.

**5.3.6.21.12** Where the source equipment is remote from a single treatment facility and an "in use" bank is unable to supply the system, the manifold shall automatically switch to the secondary bank.

**5.3.6.21.13** Where the source equipment serves multiple treatment facilities and an "in use" bank is unable to supply the system, the manifold shall automatically switch to the secondary bank.

**5.3.6.21.14** Where the source equipment is not remote and is accessible from a single treatment facility served and an "in use" bank is unable to supply the system, the manifold shall be manually (or automatically) switched to the secondary bank.

**5.3.6.22 Category 3 Warning Systems.**

**5.3.6.22.1** Warning systems for medical gas systems (oxygen and nitrous oxide) in Category 3 facilities shall provide the following alarms:

- (1) Oxygen main line pressure low
- (2) Oxygen main line pressure high
- (3) Oxygen changeover to secondary bank or about to changeover (if automatic)
- (4) Nitrous oxide main line pressure low
- (5) Nitrous oxide main line pressure high
- (6) Nitrous oxide changeover to secondary bank or about to changeover (if automatic)

**5.3.6.22.2** Warning systems shall have at least one single alarm panel in each treatment facility served by the medical gas source equipment.

**5.3.6.22.3** Alarm panels shall be located in an area of continuous surveillance while the facility is in operation.

**5.3.6.22.4** Pressure switches/sensors that monitor main line pressure shall be mounted at the source equipment with pressure alarm indicators (lamp or LED) at the alarm panel.

**5.3.6.22.5** Audible and noncancelable alarm visual signals shall indicate if the pressure in the main line increases or decreases 20 percent from the normal operating pressure.

**5.3.6.22.6** Visual indications shall remain until the situation that caused the alarm is resolved.

**5.3.6.22.7** Pressure switches/sensors shall be installed downstream of any emergency shutoff valves and any other shutoff valves in the system and shall cause an alarm for the medical gas if the pressure decreases or increases 20 percent from the normal operating pressure.

**5.3.6.22.8** A cancelable audible indication of each alarm condition that produces a sound at the alarm panel shall reinitiate the audible signal if another alarm condition occurs while the audible signal is silenced.

**5.3.6.23 Performance Criteria and Testing — Category 3 Medical Gases (Oxygen and Nitrous Oxide).**

**5.3.6.23.1 General.**

**5.3.6.23.1.1** Inspection and testing shall be performed on all new piped medical gas systems (oxygen and nitrous oxide), additions, renovations, temporary installations, or repaired systems to ensure, by a documented procedure, that all applicable provisions of this code have been adhered to and system integrity has been achieved or maintained.

**5.3.6.23.1.2** The inspection and testing reports shall be submitted directly to the party that contracted for the testing, who shall submit the report through channels to the responsible authority and any others that are required.

**5.3.6.23.1.3** Reports shall contain detailed listings of all findings and results.

**5.3.6.23.1.4** The responsible facility authority shall review the inspection and testing records prior to the use of any systems to ensure that all findings and results of the inspection and testing have been successfully completed.

**5.3.6.23.1.5** All documentation pertaining to inspections and testing shall be maintained on-site within the facility.

**5.3.6.23.1.6** The responsible facility authority shall review the inspection and testing records prior to the use of all systems to ensure that all findings and results of the inspection and testing have been successfully completed.

**5.3.6.23.2 Initial Tests for Category 3 Medical Gases (Oxygen and Nitrous Oxide).**

**5.3.6.23.2.1 General.**

(A) The initial tests required by 5.3.6.23.2 shall be performed prior to the verification tests listed in 5.3.6.23.3 by one or more of the following, who shall be qualified under ASSE 6010, *Professional Qualification Standard for Medical Gas Systems Installers*:

- (1) Installer
- (2) Representative of the system supplier
- (3) Representative of the system manufacturer
- (4) Medical gas systems verifier qualified under 5.3.6.23.3.1(A)

(B) The test gas for medical gas systems shall be oil-free, dry nitrogen NF.

(C) Where manufactured assemblies are to be installed, the tests required under 5.3.6.23.2 shall be performed as follows:

- (1) After completion of the distribution piping
- (2) Prior to installation or connection of manufactured assemblies having internal flexible hose or flexible tubing
- (3) At all station outlets on manufactured assemblies supplied through copper tubing

(D) Where plastic vacuum and scavenging piping systems are installed, they shall be visually inspected for cross-connections to positive pressure systems prior to applying positive test pressures to the copper piping systems.

**5.3.6.23.2.2 Initial Piping Blow Down.** Piping in Category 3 medical gas distribution systems shall be blown clear by a means of oil-free, dry nitrogen NF after installation of the distribution piping but before installation of station outlets and other system components (i.e., pressure alarm devices, pressure indicators, pressure relief valves, manifolds, source equipment).

**5.3.6.23.2.3 Initial Pressure Test.**

(A) Each section of the piping in Category 3 medical gas piping systems shall be pressure tested by a party qualified under 5.3.6.23.2.1(A), using oil-free, dry nitrogen NF.

(B) Initial pressure tests shall be conducted as follows:

- (1) After blow down of the distribution piping
- (2) After installation of station outlets/inlets rough-in assemblies, with test caps permitted to be used
- (3) Prior to the installation of components of the distribution piping system that would be damaged by the test pressure (e.g., pressure/vacuum alarm devices, pressure/vacuum indicators, line pressure relief valves)

(C) The source shutoff valves for the piping systems shall remain closed during the tests.

(D) The test pressure for medical gas piping shall be 1.5 times the system working pressure but not less than a gauge pressure of 1035 kPa (150 psi).

(E)\* The test pressure shall be maintained until each joint has been examined for leakage by means of a leak detectant that is safe for use with oxygen and does not contain ammonia.

(F) Leaks, if any, shall be located, repaired (if permitted), or replaced (if required) by the installer and retested.

**5.3.6.23.2.4 Initial Cross-Connection Test.** A party qualified under 5.3.6.23.2.1(A) shall determine that no cross-connections exist between the various medical gas piping systems (oxygen and nitrous oxide).

(A) The Category 3 medical gas piping systems shall be at atmospheric pressure.

(B) Faceplates for gas outlets shall be installed.

(C) The test gas for medical gas piping systems shall be oil-free, dry nitrogen NF.

(D) The source of test gas shall be connected only to the medical gas piping system being tested.

(E) The medical gas system being tested shall be pressurized to a gauge pressure of 345 kPa (50 psi).

(F) Each individual system gas outlet in each installed medical gas piping system (oxygen and nitrous oxide) shall be checked to determine that the test gas is being dispensed only from the outlets in the medical gas piping system being tested.

(G) The cross-connection test shall be repeated for each installed medical gas piping system.

(H) The proper labeling and identification of system outlets shall be confirmed during the tests.

**5.3.6.23.2.5 Initial Piping Purge Test.** The outlets in each Category 3 medical gas piping system shall be purged by a party qualified under 5.3.6.23.2.1(A) to remove any particulate matter from the distribution piping.

(A) The test gas shall be oil-free, dry nitrogen NF.

(B) Using appropriate adapters, each outlet shall be purged with an intermittent high-volume flow of test gas until the purge produces no discoloration in a clean white cloth.

(C) The purging shall be started at the furthest outlet in the system and proceed toward the source equipment.

**5.3.6.23.2.6 Initial Standing Pressure Test.** After successful completion of the initial pressure tests under 5.3.6.23.2.3, Category 3 medical gas distribution piping shall be subjected to a standing pressure test by a party qualified under 5.3.6.23.2.1(A).

(A) Tests shall be conducted after the installation of station outlet valve bodies and faceplates and other distribution system components (e.g., pressure alarm devices, pressure indicators, and line pressure relief valves).

(B) The source valve shall be closed during the test.

(C) The piping systems shall be subjected to a 24-hour standing pressure test using oil-free, dry nitrogen NF.

(D) Test pressures shall be 20 percent above the normal system operating line pressure.

(E) At the conclusion of the tests, there shall be no change in the test pressure greater than a gauge pressure of 35 kPa (5 psi).

(F) Leaks, if any, shall be located, repaired (if permitted), or replaced (if required) by the installer and retested.

### 5.3.6.23.3 System Verification for Category 3 Medical Gases (Oxygen and Nitrous Oxide).

#### 5.3.6.23.3.1 General.

(A) Verification tests shall be conducted on Category 3 medical gases (oxygen and nitrous oxide) by a party technically competent and experienced in the field of medical gas and vacuum system verification and meeting the requirements of ASSE 6030, *Professional Qualification Standard for Medical Gas Systems Verifiers*.

(B) Verification testing shall be performed by a party other than the installing contractor, the system supplier, or the system manufacturer.

(C) Verification tests shall be performed only after all tests required in 5.3.6.23.2 have been successfully completed on the medical gas piping systems.

(D) The test gas shall be oil-free, dry nitrogen NF or the system gas, where permitted.

(E) All verification tests required under 5.3.6.23.3 shall be performed after installation of any manufactured assemblies having internal hose or tubing.

(F) Where manufactured assemblies with internal tubing or hose include multiple possible connection points for terminals, each possible connection point shall be tested independently.

(G) For small projects affecting a limited number of areas, where the use of nitrogen is impractical, the system gas shall be permitted to be used for the following tests:

- (1) Standing pressure (*see 5.3.6.23.3.3*)
- (2) Cross-connection by individual pressurization (*see 5.3.6.23.3.4*)
- (3) Cross-connection by pressure differential (*see 5.3.6.23.3.5*)
- (4) Warning system (*see 5.3.6.23.3.6*)
- (5) Piping purge (*see 5.3.6.23.3.7*)
- (6) Piping particulate (*see 5.3.6.23.3.8*)
- (7) Piping purity (*see 5.3.6.23.3.9*)
- (8) Operational pressure (*see 5.3.6.23.3.10*)

(H) All verification test results shall be reported as required in 5.3.6.23.3.1.

#### 5.3.6.23.3.2 Source Equipment Verification.

(A) **General.** Source equipment verification for Category 3 medical gases (oxygen and nitrous oxide) shall be performed following the installation of the interconnecting pipelines, accessories, and source equipment.

(B) **Use of Source Equipment for Pipeline Verification Tests.** Where the source equipment and system gas is permitted to be used for verification testing of the distribution piping, the source equipment shall be verified prior to verification of the distribution piping.

(C) **Automatic Changeover.** Where medical gas sources include automatic changeover to a secondary bank, the system apparatus shall be tested for proper function, including the changeover from primary to secondary supply (with its changeover alarm signal), before the source equipment is put into service.

5.3.6.23.3.3 **Verifier Standing Pressure Test.** Category 3 medical gas piping systems (oxygen and nitrous oxide) shall be subjected to a 10-minute standing pressure test at operating line pressure using the following procedures:

- (1) The system source shutoff valve shall be closed, unless it is being used as the test gas.

- (2) After the system is filled with oil-free, dry nitrogen NF or the system gas, the test source valve shall be closed.
- (3) The piping system downstream of the valve shall show no decrease in pressure after 10 minutes.
- (4) Any leaks shall be located by the installer, repaired by the installer (if permitted), replaced by the installer (if required), and retested by the verifier.

5.3.6.23.3.4 **Verifier Cross-Connection Test by Individual Pressurization.** After closing of walls and completion of the requirements of 5.3.6.23.2, it shall be determined that no cross-connections exist between the Category 3 medical gas systems (oxygen and nitrous oxide) by either use of the following individual pressurization methods or by the pressure differential method in 5.3.6.23.3.5:

- (1) Reduce the pressure in all Category 3 medical gas systems to atmospheric.
- (2) Pressurize one of the Category 3 medical gas piping systems to a gauge pressure of 345 kPa (50 psi) using oil-free, dry nitrogen NF or the system gas.
- (3) Test each medical gas outlet using appropriate adapters to verify that the test gas pressure is present only at the outlets in the Category 3 medical gas piping system being tested.
- (4) After it has been verified that a Category 3 medical gas piping system is free of cross-connections, disconnect the source of test gas and reduce the piping to atmospheric pressure.
- (5) Proceed to test each Category 3 medical gas piping system until each is verified to be free of cross-connections.

5.3.6.23.3.5 **Verifier Cross-Connection Test by Pressure Differential.** After closing of walls and completion of the requirements of 5.3.6.23.2, it shall be determined that no cross-connections exist between the Category 3 medical gas systems (oxygen and nitrous oxide) by either use of the pressure differential method in 5.3.6.23.3.5(A) through 5.3.6.23.3.5(F) or by the individual pressurization method in 5.3.6.23.3.4.

(A) The pressure in all Category 3 medical gas systems shall be reduced to atmospheric.

(B) The test gas shall be oil-free, dry nitrogen NF or the system gas.

(C) The test gas pressures shall be gauge pressures of 345 kPa (50 psi) for oxygen and 275 kPa (40 psi) for nitrous oxide, with simultaneous maintenance of these nominal pressures throughout the test.

(D) Following the adjustment of system pressures in accordance with 5.3.6.23.3.5(C), each station outlet for each medical gas system shall be tested using the gas-specific connection for each system with a test gauge attached to verify that the correct test pressure is present at each outlet of each system.

(E) Each test gauge used in performing the test shall be calibrated with the pressure indicators for the line pressure regulators that provide the test pressures.

(F) Each station outlet shall be identified by label (and color marking, if used), and the pressure indicated on the test gauge shall be that listed in 5.3.6.23.3.5(C) for the system being tested.

#### 5.3.6.23.3.6 Verifier Warning System Tests.

(A) All warning systems that are installed for Category 3 medical gases (oxygen and nitrous oxide) shall be verified to ensure that all components function correctly prior to placing the system into service.

- (B) Permanent records of the tests shall be maintained.
- (C) Warning systems that are part of an addition to an existing piping system shall be tested prior to connection of the new piping to the existing system.
- (D) Tests of warning systems for new installations shall be performed after the verifier's cross-connection testing (*see 5.3.6.23.3.4 or 5.3.6.23.3.5*), but before purging the piping (*see 5.3.6.23.3.7*) and performing the remaining verification tests. (*See 5.3.6.23.3.8 through 5.3.6.23.3.10.*)
- (E) Test gases shall be either oil-free, dry nitrogen NF or the system gas.
- (F) The audible and noncancelable alarm signals in each treatment facility shall be checked to verify that they are in a location that will be continuously attended while the facility is in operation.
- (G) The operation of the Category 3 medical gas line pressure alarms required by 5.3.6.22.1 shall be verified.
- (H) The operation of the Category 3 changeover alarms, if provided under 5.3.6.22.1, shall be verified.
- (I) If automatic changeover is provided under 5.3.6.21.12 or 5.3.6.21.13, audible and noncancelable visual signals shall indicate whenever automatic changeover occurs or is about to occur.
- (J) Where Category 3 medical gas systems (oxygen and nitrous oxide) include other alarm features that are not mandatory in 5.3.6.21, they shall be functionally tested in accordance with their intended purpose and the equipment manufacturer's recommendations.

**5.3.6.23.3.7 Verifier Piping Purge Test.**

- (A) In order to remove any traces of particulate matter deposited in the pipelines as a result of construction, a heavy, intermittent purging of each Category 3 medical gas (oxygen and nitrous oxide) pipeline shall be performed.
- (B) The appropriate adapter shall be obtained from the facility or manufacturer, and high purge rates shall be put on each outlet.
- (C) After the purge is started, it shall be rapidly interrupted several times until the purge produces no discoloration in a white cloth loosely held over the adapter during the purge.
- (D) In order to avoid possible damage to the outlet and its components, the test shall not be conducted using any implement other than the correct adapter.

**5.3.6.23.3.8 Verifier Piping Particulate Test.** The cleanliness of the piping in each Category 3 medical gas system (oxygen and nitrous oxide) shall be verified as follows:

- (1) The test shall be performed using oil-free, dry nitrogen NF or the system gas.
- (2) A minimum of 1000 L (35 ft<sup>3</sup>) of gas shall be filtered through a clean, white 0.45 micron filter at a minimum flow rate of 100 SLPM (3.5 SCFM).
- (3) Each zone shall be tested at the outlet most remote from the source.
- (4) The filter shall accrue no more than 0.001 g (1 mg) of matter from any outlet tested.

**5.3.6.23.3.9\* Verifier Piping Purity Test.** For each Category 3 medical gas system (oxygen and nitrous oxide), the purity of the piping system shall be verified as follows:

- (1) The tests shall be performed with oil-free, dry nitrogen NF or the system gas.

- (2) The outlet most remote from the source shall be tested for total non-methane hydrocarbons and compared to the source gas.
- (3) If the system gas is used as the source gas, it shall be tested at the source equipment.
- (4) The difference between the two tests shall in no case exceed 5 ppm of total non-methane hydrocarbons.
- (5) The difference between the two tests shall in no case exceed 5 ppm halogenated hydrocarbons.
- (6) The moisture concentration of the outlet test shall not exceed 500 ppm or an equivalent pressure dew point of -12°C (10°F) at a gauge pressure of 345 kPa (50 psi).

**5.3.6.23.3.10 Verifier Operational Pressure Test.**

- (A) Operational pressure tests shall be performed at each station outlet in Category 3 medical gas piping systems (oxygen and nitrous oxide) where the user makes connections and disconnections.
- (B) Tests shall be performed using either oil-free, dry nitrogen NF or the system gas.

(C) Medical gas outlets (oxygen and nitrous oxide) shall deliver 50 SLPM (1.8 SCFM) with a pressure drop of not more than 35 kPa (5 psi) from a gauge pressure of 345 kPa to 380 kPa (50 psi to 55 psi).

**5.3.6.23.3.11\* Verifier Gas Concentration Test.** After purging each Category 3 medical gas piping system with the gas of system designation, the following shall be performed:

- (1) Each medical gas outlet (oxygen and nitrous oxide) shall be analyzed for concentration of gas by volume.
- (2) Analysis shall be conducted with instruments designed to measure the specific gas dispensed.
- (3) Allowable concentrations shall be as follows:
  - (a) Oxygen ≥99 percent oxygen
  - (b) Nitrous oxide ≥99 percent nitrous oxide

**5.3.6.23.3.12 Verifier Final Tie-In Test.**

- (A) Prior to the connection of any new piping in extensions or additions to an existing piping system, the final tests in 5.3.6.23.3 shall be successfully performed on the new work.
- (B) Each joint in the final connection between the new work and the existing system shall be leak-tested with the gas of system designation at the normal operating pressure by means of a leak detector that is safe for use with oxygen and does not contain ammonia.
- (C) Vacuum joints shall be tested using an ultrasonic leak detector or other means that allow detection of leaks in an active vacuum system.
- (D) Immediately after a final connection is made and leak-tested, the specific altered zone and components in the immediate zone or area that is downstream from the point or area of intrusion shall be purged per 5.3.6.23.3.7.

**5.3.6.23.3.13 Verification of Labeling.** The labeling and identification of source equipment, shutoff valves, alarm panels, and station outlets for Category 3 medical gas systems (oxygen and nitrous oxide) shall be verified.

**5.3.7\* Category 3 Gas-Powered Device Supply Systems (Compressed Air and Nitrogen).**

**5.3.7.1 General Requirements.**

**5.3.7.1.1** Category 3 gas-powered device supply systems shall be used to drive dynamic devices, to dry surfaces for patient

treatment, to drive vacuum turbines, and to remove excess moisture from instruments before further processing and for other general compressed gas uses in Category 3 facilities.

**5.3.7.1.2** Category 3 gas-powered device supply systems shall be permitted to be used to supply power to gas-driven devices for scavenging, but only where the exhaust of the scavenging device is a closed vent to the outside of the building.

**5.3.7.1.3\*** Category 3 gas-powered device supply systems shall be furnished by the equipment manufacturer(s) or supplier(s), who shall be familiar with the proper application of the equipment and shall supervise its installation.

**5.3.7.1.4** Installers of Category 3 gas-powered device supply systems shall be experienced in the installation and testing of such systems and the requirements of this code.

### **5.3.7.2 Piping for Gas-Powered Devices.**

#### **5.3.7.2.1 Tubes.**

**5.3.7.2.1.1** Tubes shall be in accordance with one of the following:

- (1) ASTM B 819, *Standard Specification for Seamless Copper Tube for Medical Gas Systems*, medical gas tube, not less than Type L
- (2) ASTM B 88, *Standard Specification for Seamless Copper Water Tube*, water tube, not less than Type L
- (3) ASTM B 280, *Standard Specification for Seamless Copper Tubing for Air Conditioning and Refrigeration Field Service*, ACR tube (O.D. size)

**5.3.7.2.1.2** Tubing shall be hard temper or annealed (soft temper).

**5.3.7.2.2 Fittings.** Fittings for Category 3 gas-powered device supply piping shall be one of the following:

- (1) Brazed or soldered fittings complying with ASME B16.22, *Wrought Copper and Copper Alloy Solder-Joint Pressure Fittings*
- (2) Brazed fittings complying with ASME B16.50, *Wrought Copper and Copper Alloy Braze-Joint Pressure Fittings*
- (3) Brazed fittings complying with ASME B16.22, with socket depths equal to or greater than braze-joint pressure fittings in compliance with ANSI/ASME B16.50.
- (4) Flared fittings complying with ASME B16.26, *Cast Copper Alloy Fittings for Flared Copper Tubes*
- (5) Compression fittings ( $\frac{3}{4}$  in. maximum size)
- (6) Special-purpose fittings permitted for Category 1 medical gas piping

#### **5.3.7.2.3 Joints.**

**5.3.7.2.3.1** Joints for Category 3 gas-powered device supply piping shall be of the brazed, soldered, threaded, flared, or compression type.

**5.3.7.2.3.2** Where joints are brazed, they shall comply with the requirements for Category 3 medical gas piping in 5.3.6.1 through 5.3.6.10.

**5.3.7.2.3.3** Soldered joints in Category 3 gas-powered supply piping shall be made in accordance with ASTM B 828, *Standard Practice for Making Capillary Joints by Soldering of Copper and Copper Alloy Tube and Fittings*, using a “lead-free” solder filler metal containing not more than 0.2 percent lead by volume that complies with ASTM B 32, *Standard Specification for Solder Metal*.

### **5.3.7.3 Installation of Gas-Powered Device Piping.**

**5.3.7.3.1 Pipe Sizing.** Piping systems shall be designed and sized to deliver the required flow rates at the utilization pressures.

**5.3.7.3.2 Protection of Piping.** Piping shall be protected in accordance with 5.3.6.11.4.

**5.3.7.3.3 Pipe Support.** Pipe support shall be in accordance with 5.3.6.12.

**5.3.7.3.4 Underground Piping Outside of Buildings.** Buried piping outside of buildings shall be in accordance with 5.3.6.13.

**5.3.7.3.5 Underground Piping Within Buildings.** Underground piping within buildings shall be in accordance with 5.3.6.14.

#### **5.3.7.3.6 Piping Within Floor Slabs.**

**5.3.7.3.6.1** Category 3 gas-powered device piping (compressed air and nitrogen) that is installed within floor slabs shall be enclosed in a conduit, in flexible plastic tubing, or by other means to prevent contact between the copper tubing and concrete.

**5.3.7.3.6.2** During construction, access shall be provided at any joints for visual inspection and leak testing.

**5.3.7.4 Valves in Gas-Powered Device Piping.** Shutoff valves shall be permitted to be installed in Category 3 gas-powered device piping.

### **5.3.7.5 Location of Gas-Powered Device Source Equipment.**

**5.3.7.5.1** Source equipment for Category 3 gas-powered devices shall be one or more of the following:

- (1) One or more air compressors
- (2) One or more air compressors with compressed air cylinders
- (3) Nitrogen cylinders

**5.3.7.5.2** Air compressors for Category 3 gas-powered devices shall be installed in a designated mechanical equipment area, heated and ventilated in accordance with 5.1.3.3.2 and 5.1.3.3.3, and have required utilities (e.g., electrical power, drains, lighting).

**5.3.7.5.3** Where nitrogen or compressed air in cylinders is used, the cylinders shall be permitted to be located in a compressor equipment room.

**5.3.7.5.4** Nitrogen and compressed air cylinders shall be permitted to be located in enclosures for Category 3 medical gases (oxygen and nitrous oxide).

#### **5.3.7.6 Air Compressor Source Equipment.**

**5.3.7.6.1 General.** Category 3 compressed air compressor supply systems shall include the following:

- (1) Disconnect switch(es)
- (2) Motor-starting device(s)
- (3) Motor overload protection device(s)
- (4) One or more compressors
- (5) For single, duplex, or multiple compressor systems, means for activation/de-activation of each individual compressor
- (6) When multiple compressors are used, manual or automatic means to alternate individual compressors
- (7) When multiple compressors are used, manual or automatic means to activate the additional unit(s) should the in-service unit(s) be incapable of maintaining adequate pressure
- (8) Intake filter–muffler(s) of the dry type
- (9) Receiver(s) with a manual or automatic drain
- (10) Shutoff valves
- (11) Compressor discharge check valve(s) (for multiple compressors)
- (12) Air dryer(s) that maintains a minimum of 40 percent relative humidity at operating pressure and temperature

- (13) In-line final particulate/coalescing filters rated at 0.01 micron, with filter status indicator to ensure the delivery of compressed air with a maximum allowable 0.05 ppm liquid oil
- (14) Pressure regulator(s)
- (15) Pressure relief valve
- (16) Pressure indicator
- (17) Moisture indicator

#### 5.3.7.6.2 Receiver(s).

**5.3.7.6.2.1** The receiver(s) shall have the capacity to prevent short cycling of the compressor(s).

**5.3.7.6.2.2** The receiver(s) shall comply with Section VIII, "Unfired Pressure Vessels," of the ASME *Boiler and Pressure Vessel Code*.

#### 5.3.7.6.3\* Moisture Indicator.

**5.3.7.6.3.1** The moisture indicator shall be located in the active airstream prior to, or after, the receiver and upstream of any system pressure regulators.

**5.3.7.6.3.2** The moisture indicator shall indicate (e.g., by color change, digital readout, or other method understood by the user) when the relative humidity of the compressed air exceeds 40 percent at line pressure and temperature.

**5.3.7.6.4 Pressure Relief Valve Discharge.** Pressure relief valves for compressed air systems having less than 84,950 L (3000 ft<sup>3</sup>) at STP shall be permitted to discharge locally indoors in a safe manner that will not restrict the flow.

#### 5.3.7.6.5\* Source of Compressor Intake Air.

**5.3.7.6.5.1** Air sources for a compressor(s) located inside the building shall meet the following requirements:

- (1) They shall be located within a space where no chemical-based materials are stored or used.
- (2) They shall be located in a space that is not used for patient medical treatment.
- (3) They shall not be taken from a room or space in which there is an open or semi-open discharge from a Category 3 vacuum or scavenging system.

**5.3.7.6.5.2** Air sources for a compressor(s) located outside the building shall be drawn from locations where no contamination from vacuum or scavenging system discharges or particulate matter is anticipated.

#### 5.3.7.7 Compressed Air Cylinder Source Equipment.

**5.3.7.7.1** Compressed air cylinders shall be permitted to be installed in enclosures for Category 3 medical gases (oxygen and nitrous oxide) as described in 5.3.6.20.2 or in a mechanical room.

**5.3.7.7.2** Compressed air cylinder source equipment shall include the following:

- (1) One or more cylinders of compressed air, each providing at least an average day's supply
- (2) Manifold if primary and secondary cylinders are provided
- (3) Line pressure regulating valve
- (4) Check valve downstream from the pressure regulating valve
- (5) Pressure relief valve set at 50 percent above the normal line pressure and located downstream from the check valve specified in 5.3.7.7.2(4)

**5.3.7.7.3** Mechanical means shall be provided to ensure that the compressed air cylinder gas source equipment is connected to the correct gas distribution piping system.

**5.3.7.7.4** Threaded connections to manifolds shall comply with CGA V-5, *Diameter-Index Safety System (Noninterchangeable Low Pressure Connections for Medical Gas Applications)*.

**5.3.7.7.5** Flexible connectors shall have a gauge pressure rating not less than 6895 kPa (1000 psi).

**5.3.7.7.6** Flexible connectors of other than all-metal construction that connect manifolds to the gas distribution piping shall not exceed 1.52 m (5 ft) in length and shall not penetrate walls, floors, ceilings, or partitions.

**5.3.7.7.7** Pressure relief valves for compressed air cylinder systems having less than 84,950 L (3000 ft<sup>3</sup>) at STP shall be permitted to discharge locally indoors in a safe manner that will not restrict the flow.

#### 5.3.7.8\* Nitrogen Source Equipment.

**5.3.7.8.1** Nitrogen source equipment shall be permitted to be installed in enclosures for Category 3 medical gases (oxygen and nitrous oxide) as described in 5.3.6.20.2 or in a mechanical room.

**5.3.7.8.2** Nitrogen source equipment shall include the following:

- (1) One or more cylinders of nitrogen NF, each providing at least an average day's supply
- (2) Manifold, if primary and secondary cylinders are provided
- (3) Line pressure regulating valve
- (4) Check valve downstream from the pressure regulating valve
- (5) A pressure relief valve set at 50 percent above the normal line pressure and located downstream from the check valve specified in 5.3.7.8.2(4)
- (6) Pressure relief valve discharge piped to outdoors at a point that will not create a probable hazard and that is turned down to prevent the entry of rain or snow

**5.3.7.8.3** Mechanical means shall be provided to ensure that the nitrogen gas source equipment is connected to the correct gas distribution piping system.

**5.3.7.8.4** Cylinder valve outlets for nitrogen shall comply with CGA V-1, *Compressed Gas Association Standard for Compressed Gas Cylinder Valve Outlet and Inlet Connections*.

**5.3.7.8.5** Threaded connections to manifolds shall comply with CGA V-5, *Diameter-Index Safety System (Noninterchangeable Low Pressure Connections for Medical Gas Applications)*.

**5.3.7.8.6** Flexible connectors shall have a gauge pressure rating not less than 6895 kPa (1000 psi).

**5.3.7.8.7** Flexible connectors of other than all-metal construction that connect manifolds to the gas distribution piping shall not exceed 1.52 m (5 ft) in length and shall not penetrate walls, floors, ceilings, or partitions.

#### 5.3.8 Category 3 Vacuum and Scavenging Systems.

##### 5.3.8.1 General Requirements.

**5.3.8.1.1** Category 3 vacuum and scavenging systems shall be furnished by an equipment manufacturer(s) or a supplier(s) who is familiar with the proper application of the equipment and shall be installed under their supervision.

**5.3.8.1.2** Installers of Category 3 vacuum and scavenging systems shall be experienced in the installation and testing of such systems and the requirements of this code.

**5.3.8.1.3** Any water supply and drain piping associated with vacuum or scavenging source equipment shall comply with the locally adopted plumbing code.

**5.3.8.2 Piping for Vacuum and Scavenging Systems.**

**5.3.8.2.1** Piping for Category 3 vacuum and scavenging systems shall be copper, PVC plastic, or CPVC plastic.

**5.3.8.2.2** Copper piping shall comply with the requirements for Category 3 gas-powered supply piping as follows:

- (1) Copper tubing shall be in accordance with 5.3.7.2.1.
- (2) Copper fittings shall be in accordance with 5.3.7.2.2.
- (3) Joints in copper tubing shall be in accordance with 5.3.7.2.3.

**5.3.8.2.3** PVC plastic piping shall be in accordance with the following:

- (1) PVC plastic pipe shall be Schedule 40 or Schedule 80, complying with ASTM D 1785, *Standard Specification for Poly (Vinyl Chloride) (PVC) Plastic Pipe, Schedules 40, 80, and 120*.
- (2) PVC plastic fittings shall be Schedule 40 or Schedule 80 to match the pipe, complying with ASTM D 2466, *Standard Specification for Poly (Vinyl Chloride) (PVC) Plastic Pipe Fittings, Schedule 40*, or ASTM D 2467, *Standard Specification Poly (Vinyl Chloride) (PVC) Plastic Pipe Fittings, Schedule 80*.
- (3) Joints in PVC plastic piping shall be solvent-cemented in accordance with ASTM D 2672, *Standard Specification for Joints for IPS PVC Pipe Using Solvent Cement*.

**5.3.8.2.4** CPVC plastic piping shall be iron pipe size (IPS) or copper tube size (CTS) in accordance with the following:

- (1) CPVC IPS plastic pipe shall be Schedule 40 or Schedule 80, complying with ASTM F 441, *Standard Specification for Chlorinated Poly (Vinyl Chloride) (CPVC) Plastic Pipe, Schedules 40 and 80*.
- (2) CPVC IPS plastic fittings shall be Schedule 40 or Schedule 80 to match the pipe, complying with ASTM F 438, *Standard Specification for Socket-Type Chlorinated Poly (Vinyl Chlorinated) (CPVC) Plastic Pipe Fittings, Schedule 40*, or ASTM F 439, *Standard Specification for Chlorinated Poly (Vinyl Chlorinated) (CPVC) Plastic Pipe Fittings, Schedule 80*.
- (3) CPVC CTS plastic pipe and fittings ½ in. through 2 in. size shall be SDR 11, complying with ASTM D 2846, *Standard Specification for Chlorinated Poly (Vinyl Chloride) (CPVC) Plastic Hot- and Cold-Water Distribution Systems*.
- (4) Solvent cement for joints in CPVC plastic piping shall comply with ASTM F 493, *Solvent Cements for CPVC Pipe and Fittings*.

**5.3.8.3 Installation of Vacuum and Scavenging Piping.**

**5.3.8.3.1 Pipe Sizing.** Piping systems shall be designed and sized to draw the required flow rates at the utilization vacuums.

**5.3.8.3.2 Protection of Piping.** Piping shall be protected in accordance with 5.3.6.11.4.

**5.3.8.3.3 Copper Pipe Support.** Pipe support for copper piping shall be in accordance with 5.3.6.12.

**5.3.8.3.4 Plastic Pipe Support.** The maximum support spacing for plastic pipe shall be in accordance with Table 5.3.8.3.4.

**5.3.8.3.5 Underground Piping Outside of Buildings.** Buried piping outside of buildings shall be in accordance with 5.3.6.13.

**5.3.8.3.6 Underground Piping Within Buildings.** Underground piping within buildings shall be in accordance with 5.3.6.14.

**Table 5.3.8.3.4 Maximum Plastic Pipe Support Spacing**

Pipe Size	Hanger Spacing	
	mm	ft
DN15 (NPS ½) (⅝ in. O.D.)	1220	4.00
DN20 (NPS ¾) (⅞ in. O.D.)	1220	4.00
DN25 (NPS 1) (1⅛ in. O.D.)	1320	4.33
DN32 (NPS 1¼) (1⅜ in. O.D.)	1320	4.33
DN40 (NPS 1½) (1⅝ in. O.D.)	1420	4.66
DN50 (NPS 2) (2⅜ in. O.D.)	1420	4.66
DN65 (NPS 2½) (2⅞ in. O.D.) and larger	1520	5.00
Vertical risers, all sizes, every floor, but not to exceed	3040	10.00

**5.3.8.3.7 Piping Within Floor Slabs.**

**5.3.8.3.7.1** Copper Category 3 vacuum and scavenging piping that is installed within floor slabs shall be enclosed in a conduit, flexible plastic tubing, or other means to prevent contact between the copper tubing and concrete.

**5.3.8.3.7.2** Plastic Category 3 vacuum and scavenging piping shall be permitted to contact concrete.

**5.3.8.3.7.3** During construction, access shall be provided at all joints for visual inspection and leak testing.

**5.3.8.3.7.4** Care shall be taken to protect plastic piping from damage from vibrators while wet concrete is being consolidated.

**5.3.8.3.8 Valves in Vacuum and Scavenging Systems.** Shutoff valves shall be permitted to be installed in Category 3 vacuum and scavenging piping.

**5.3.8.3.9\* Category 3 Vacuum and Scavenging Source Equipment.**

**5.3.8.3.9.1** Category 3 vacuum sources shall include the following:

- (1) Vacuum pump or pumps suited for wet or dry service as intended in the system design
- (2) If intended for wet service, properly vented liquid/air separator

**5.3.8.3.9.2** Category 3 vacuum and scavenging source equipment shall be obtained from, and be installed under the supervision of, the manufacturer(s) or supplier(s) who is familiar with its installation, operation, and use.

**5.3.8.3.10 Drainage from Vacuum Equipment.** None of the requirements of 5.3.8.3.10.1 through 5.3.8.3.10.6 for drainage in Category 3 vacuum systems shall supersede provisions of the local plumbing code.

**5.3.8.3.10.1** Liquids drained from a Category 3 vacuum source shall discharge indirectly to a sanitary drainage system through an approved air gap to a trapped and vented drain.

**5.3.8.3.10.2** The clear air gap between a vacuum drain outlet, or indirect drain pipe, and the flood category rim of an indirect waste receptor, or other point of disposal, shall be not less than twice the diameter of the effective opening of the drain served, but not less than 25.4 mm (1 in.), unless the local plumbing code requires a larger air gap.

**5.3.8.3.10.3** Where the drainage is from a waste holding tank on the suction side of the vacuum source, the following requirements shall be met:

- (1) A check valve shall be installed in the drain line from the holding tank between the tank and any vent lines.
- (2) The trap in the building drainage system shall be the deep-seal type that is conventionally vented within the plumbing system.
- (3) An additional vent shall be installed between the holding tank drain check valve and the drain trap, on the inlet side of the trap, to close and seal the check valve while the holding tank is operating under vacuum and collecting waste.
- (4) The additional vent described in 5.3.8.3.10.3(3) shall be permitted to be connected to the plumbing system vents, unless a drain pump system with a positive pressure discharge is installed, in which case 5.3.8.3.10.4 shall apply.
- (5) Both of the vents in 5.3.8.3.10.3(3) and (4) shall extend vertically to not less than 152 mm (6 in.) above the top of the holding tank before turning horizontal.
- (6) Outdoor vents shall be protected against the entry of insects, vermin, debris, and precipitation.
- (7) The trap and drain branch shall be not less than two pipe sizes larger than the waste pipe from the separator, but not less than DN50 (NPS 2).
- (8) The trap seal shall be not less than 100 mm (4 in.) deep.
- (9) The vent for the vacuum check valve shall be not less than the size of the check valve.
- (10) The vent for the trap shall be not less than one-half the size of the trap and drain branch.

**5.3.8.3.10.4\*** Where the drainage is from a waste holding tank on the suction side of the vacuum source and a positive discharge pump drain system is in place, the following requirements shall be met:

- (1) The pump shall drain indirectly to the plumbing system through an air gap equal to the diameter of the discharge pipe but not less than 25.4 mm (1 in.) above the rim.
- (2) A check valve shall be installed in the drain line from the holding tank to the drain.
- (3) The trap in the building drainage system shall be the deep-seal type that is conventionally vented within the plumbing system.
- (4) The trap and drain branch shall be not less than two pipe sizes larger than the waste pipe from the separator, but not less than DN40 (NPS 1½).
- (5) The trap seal shall be at least two times the exhaust back pressure in the separator but not less than 100 mm (4 in.) deep.

**5.3.8.3.10.5** Where the drainage is at a positive pressure from an air/waste separator on the discharge side of the vacuum source, the following requirements shall be met:

- (1) Where there is a positive pressure discharge from a vacuum pump, it shall be required to drain through an air/waste separator.
- (2) Discharge shall be either of the following:
  - (a) Direct into a trap in the building drainage system that is the deep-seal type and is conventionally vented within the plumbing system
  - (b) Indirect to the plumbing system through an air gap equal to the diameter of the discharge pipe, but not less than 25.4 mm (1 in.) above the rim

- (3) The trap vent shall extend vertically to not less than 152 mm (6 in.) above the top of the separator before turning horizontal.
- (4) Outdoor vents shall be protected against the entry of insects, vermin, debris, and precipitation.
- (5) The trap and drain branch shall be two pipe sizes larger than the waste pipe from the separator, but not less than DN40 (NPS 1½).
- (6) The air/waste separator vent shall be the full size of the separator vent connection.
- (7) The separator vent shall be separate from the building vent piping.

**5.3.8.3.10.6** The indirect drainage from vacuum equipment shall discharge to the sanitary drainage system through an approved air gap without causing overflow or splatter on building surfaces.

**5.3.8.3.11 Vacuum Exhaust.** The exhaust from Category 3 vacuum and scavenging sources shall comply with the following:

- (1) The exhaust shall be piped to the outside through a separate vent system.
- (2) The exhaust point shall be chosen to minimize the hazards of noise.
- (3) The exhaust point shall be remote from any door, window, or other opening into the building.
- (4) The exhaust point shall be located at a different elevation than air intakes.
- (5) The exhaust point shall not be located where affected by prevailing winds, adjacent buildings, topography, or other obstacles to the rapid dispersion of the exhaust gases.
- (6) The exhaust point shall be protected against the entry of insects, vermin, debris, and precipitation.
- (7) The exhaust piping shall be sized to prevent back pressure greater than the pump manufacturer's recommendations.
- (8)\*Where multiple pumps exhaust through a common pipe, each pump shall be fitted with a check valve or a manual isolation valve or shall be arranged to allow capping the individual pump exhausts when a pump is removed for service.
- (9) Where multiple pumps exhaust through a common pipe, piping shall be arranged following the pump manufacturer's recommendations.

**5.3.9 Performance Criteria and Testing — Category 3 Gas-Powered Device Supply Systems, Vacuum Systems, and Scavenging Systems.**

**5.3.9.1 General.**

**5.3.9.1.1** Inspection and testing shall be performed on all new piped Category 3 gas-powered device supply systems (compressed air and nitrogen), Category 3 vacuum systems, Category 3 scavenging systems, and their additions, renovations, temporary installations, or repaired systems to ensure, by a documented procedure, that all applicable provisions of this document have been adhered to and system integrity has been achieved or maintained.

**5.3.9.1.2** The inspection and testing reports shall be submitted directly to the party that contracted for the testing, who shall submit the report through channels to the responsible authority and any others that are required.

**5.3.9.1.3** Reports shall contain detailed listings of all findings and results.



**5.3.9.1.4** The responsible facility authority shall review the inspection and test records prior to the use of any systems to ensure that all findings and results of the inspections and tests have been successfully completed.

**5.3.9.1.5** All documentation pertaining to inspections and testing shall be maintained on-site within the facility.

**5.3.9.1.6** Before piping systems are initially put into use, the Category 3 health care facility authority shall be responsible for ascertaining that the gas/vacuum delivered at each outlet/inlet is that shown on the outlet/inlet label and that the proper connecting fittings are installed for the specific gas or vacuum.

**5.3.9.2 Initial Testing of Category 3 Gas-Powered Device Supply Systems, Category 3 Vacuum Systems, and Category 3 Scavenging Systems.**

**5.3.9.2.1 General.**

**5.3.9.2.1.1** The initial tests required by 5.3.9.2 shall be performed prior to the final tests required by 5.3.9.3.

**5.3.9.2.1.2** Initial tests shall be conducted by one or more of the following, who shall be experienced in the installation, operation, and testing of Category 3 gas-powered device supply systems, vacuum systems, and scavenging systems:

- (1) Installer
- (2) Representative of the system supplier
- (3) Representative of the system manufacturer
- (4) Medical gas system's verifier qualified under 5.3.6.23.3.1(A)

**5.3.9.2.1.3** The test gas for Category 3 gas-powered device supply systems shall be oil-free, dry nitrogen NF or the system gas.

**5.3.9.2.1.4** Where manufactured assemblies are to be installed, the initial tests required under 5.3.9.2 shall be performed as follows:

- (1) After completion of the distribution piping
- (2) Prior to installation or connection of manufactured assemblies having internal tubing or hose.
- (3) At all outlets and inlets on manufactured assemblies having internal copper tubing

**5.3.9.2.2 Blow Down.** Piping in Category 3 gas-powered device supply systems shall be blown clear using oil-free, dry nitrogen NF as follows:

- (1) After installation of the distribution piping
- (2) After installation of outlet shutoff valves
- (3) Before connection to the use points
- (4) Before installation of system components (e.g., pressure indicators, pressure relief valves, manifolds, source equipment)

**5.3.9.2.3 Initial Pressure Test for Copper Piping Systems.**

**5.3.9.2.3.1** Each section of the piping in Category 3 gas-powered device supply systems, copper vacuum systems, and copper scavenging systems shall be pressure tested using oil-free, dry nitrogen NF or the system gas.

**5.3.9.2.3.2** Initial pressure tests shall be conducted as follows:

- (1) After blow down of the distribution piping
- (2) After installation of outlet and inlet shutoff valves station outlets and inlets

- (3) Prior to the installation of components of the distribution piping system that would be damaged by the test pressure (e.g., pressure/vacuum indicators, line pressure relief valves)

**5.3.9.2.3.3** The source shutoff valves for the piping systems shall remain closed during the tests, unless being used for the pressure test gas.

**5.3.9.2.3.4** The test pressure shall be 1.5 times the system working pressure but not less than a gauge pressure of 1035 kPa (150 psi).

**5.3.9.2.3.5** The test pressure shall be maintained until each joint has been examined for leakage by means of a leak detectant that is safe for use with oxygen and does not contain ammonia.

**5.3.9.2.3.6** Leaks, if any, shall be located, repaired (if permitted) or replaced (if required) by the installer, and retested.

**5.3.9.2.4 Initial Leak Test for Category 3 Plastic Vacuum and Scavenging Piping Systems.**

**5.3.9.2.4.1** Each section of the piping in Category 3 vacuum and scavenging systems with plastic piping shall be leak tested using a test vacuum or the vacuum source equipment.

**5.3.9.2.4.2** If installed, the vacuum source shutoff valves for the piping systems shall remain closed during the tests, unless being used for the leak test vacuum source.

**5.3.9.2.4.3** The leak test vacuum shall be a minimum of 300 mm (12 in.) HgV.

**5.3.9.2.4.4** The test vacuum shall be maintained until each joint has been examined for leakage by means of a leak detectant that is safe for use with oxygen and does not contain ammonia.

**5.3.9.2.4.5** Leaks, if any, shall be located, repaired or replaced (if required) by the installer, and retested.

**5.3.9.2.5 Initial Cross-Connection Test for Copper Piping Systems.**

**5.3.9.2.5.1** Tests shall be conducted to determine that no cross-connections exist between the Category 3 gas-powered device supply piping systems (compressed air and nitrogen), Category 3 copper vacuum piping systems, and Category 3 copper scavenging piping systems.

**5.3.9.2.5.2** The piping systems shall be at atmospheric pressure.

**5.3.9.2.5.3** The test gas shall be oil-free, dry nitrogen NF or compressed air.

**5.3.9.2.5.4** The source of test gas shall be connected only to the piping system being tested.

**5.3.9.2.5.5** The piping system being tested shall be pressurized to a gauge pressure of 345 kPa (50 psi).

**5.3.9.2.5.6** The individual system gas outlet and vacuum inlet in each installed gas-powered device and copper vacuum or copper scavenging piping system shall be checked to determine that the test gas pressure is present only at the piping system being tested.

**5.3.9.2.5.7** The cross-connection test shall be repeated for each installed Category 3 piping system for gas-powered devices and for vacuum and scavenging with copper piping.

**5.3.9.2.5.8** The proper labeling and identification of system outlets/inlets shall be confirmed during the tests.

**5.3.9.2.6 Initial Cross-Connection Test for Category 3 Plastic Vacuum and Scavenging Piping Systems.**

**5.3.9.2.6.1** Tests shall be conducted to determine that no cross-connections exist between any Category 3 plastic vacuum piping systems or Category 3 plastic scavenging piping systems and any Category 3 gas-powered device supply systems.

**5.3.9.2.6.2** The vacuum source shutoff valves for the vacuum piping systems shall remain closed during the tests, unless they are being used for the cross-connection test vacuum source.

**5.3.9.2.6.3** The cross-connection test vacuum shall be a minimum of 300 mm (12 in.) HgV.

**5.3.9.2.6.4** The source of test vacuum shall be connected only to the vacuum piping system being tested.

**5.3.9.2.6.5** The individual gas-powered device system gas outlets and vacuum/scavenging system inlets shall be checked to determine that the test vacuum is only present at the vacuum/scavenging piping system being tested.

**5.3.9.2.6.6** The cross-connection tests shall be repeated for each installed vacuum and scavenging system with plastic piping.

**5.3.9.2.6.7** The proper labeling and identification of system outlets/inlets shall be confirmed during the tests.

**5.3.9.2.7 Initial Piping Purge Test for Gas-Powered Device Systems.**

**5.3.9.2.7.1** The outlets in each Category 3 gas-powered device supply piping system shall be purged to remove any particulate matter from the distribution piping.

**5.3.9.2.7.2** The test gas shall be oil-free, dry nitrogen NF or the system gas.

**5.3.9.2.7.3** Each outlet shall be purged with an intermittent high-volume flow of test gas until the purge produces no discoloration in a clean white cloth.

**5.3.9.2.7.4** The purging shall be started at the furthest outlet in the system and proceed towards the source equipment.

**5.3.9.2.8 Initial Standing Pressure Test for Gas-Powered Device Systems Piping.** After successful completion of the initial pressure tests under 5.3.9.2.3, Category 3 gas-powered device distribution piping shall be subjected to a standing pressure test.

**5.3.9.2.8.1** Tests shall be conducted after the installation of outlet valves and other distribution system components (e.g., pressure indicators and line pressure relief valves).

**5.3.9.2.8.2** The source valve shall be closed unless the source gas is being used for the test.

**5.3.9.2.8.3** The piping systems shall be subjected to a 24-hour standing pressure test using oil-free, dry nitrogen NF or the system gas.

**5.3.9.2.8.4** Test pressures shall be 20 percent above the normal system operating line pressure.

**5.3.9.2.8.5** At the conclusion of the tests, there shall be no change in the test pressure greater than a gauge pressure of 35 kPa (5 psi).

**5.3.9.2.8.6** Leaks, if any, shall be located, repaired (unless prohibited) or replaced (if required) by the installer, and retested.

**5.3.9.3 Final Testing of Category 3 Gas-Powered Device Supply Systems, Vacuum Systems, and Scavenging Systems.**

**5.3.9.3.1 General.**

**5.3.9.3.1.1** Final testing of gas-powered device systems, vacuum systems, and scavenging systems shall be performed only after all initial tests required by 5.3.9.2 have been performed.

**5.3.9.3.1.2** The final tests required by 5.3.9.3.2 through 5.3.9.3.6 shall be performed by one or more of the following, who shall be experienced with the installation, operation, and testing of Category 3 gas-powered device supply systems, vacuum systems, and scavenging systems:

- (1) Installer
- (2) Representative of the system supplier
- (3) Representative of the system manufacturer
- (4) Medical gas systems verifier qualified under 5.3.6.23.3.1 (A)

**5.3.9.3.1.3** The test gas shall be oil-free, dry nitrogen NF or the system gas or vacuum.

**5.3.9.3.2 Final Standing Pressure Test (Category 3 Gas-Powered Devices).** Each gas-powered device piping system shall be subjected to a 10-minute standing pressure test at operating line pressure using the following procedures:

- (1) After the system is filled with oil-free, dry nitrogen NF or the system gas, the source valve shall be closed.
- (2) The piping system downstream of the valve shall show no decrease in pressure after 10 minutes.
- (3) Any leaks found shall be located, repaired (unless prohibited) or replaced (if required) by the installer, and retested.

**5.3.9.3.3 Final Standing Vacuum Test (Category 3 Vacuum and Scavenging Systems).** Each Category 3 vacuum and scavenging piping system shall be subjected to a 10-minute standing vacuum test at operating line vacuum using the following procedures:

- (1) After the system has stabilized at the operating line vacuum, the source valve and any zone valves shall be closed.
- (2) The piping system upstream of the valves shall show no decrease in vacuum after 10 minutes.
- (3) Leaks, if any, shall be located, repaired (unless prohibited) or replaced (if required) by the installer, and retested.

**5.3.9.3.4 Final Cross-Connection Test (Category 3 Gas-Powered Devices and Vacuum and Scavenging Systems).** After closing of walls and completion of the requirements of 5.3.9.2, it shall be determined that no cross-connections exist between the piping systems for Category 3 gas-powered devices and vacuum and scavenging systems using the following method:

- (1) Test each piping system independently, starting with the vacuum and scavenging systems first, and check that the test vacuum is present only at inlets of the system being tested.
- (2) Reduce all piping systems to atmospheric pressure.
- (3) Operate the Category 3 vacuum or scavenging system being tested at the normal system vacuum, using the source equipment.
- (4) Test each Category 3 gas-powered device gas outlet and vacuum or scavenging inlet using appropriate adapters to verify that vacuum is present only at the vacuum inlets in the system being tested, and not at any gas-powered device gas outlets or inlets of other vacuum or scavenging systems.
- (5) Shut down the vacuum source equipment and slowly break the vacuum in the vacuum piping system, increasing its pressure to atmospheric.

- (6) Test each Category 3 vacuum and scavenging system until all are determined to be free of cross-connections.
- (7) Using oil-free, dry nitrogen NF or the system gas, pressurize the gas-powered device piping system to a gauge pressure of 345 kPa (50 psi).
- (8) Test each gas-powered device gas outlet using appropriate adapters to verify that the test gas pressure is present only at the outlets in the gas-powered device system being tested.
- (9) After it has been determined that a gas-powered device piping system is free of cross-connections, disconnect the source of test gas and reduce the piping to atmospheric pressure.
- (10) Proceed to test each gas-powered device piping system until all are determined to be free of cross-connections.

**5.3.9.3.5 Final Piping Purge Test (Category 3 Gas-Powered Devices).** In order to remove any traces of particulate matter deposited in the pipelines as a result of construction, a heavy, intermittent purging of each gas-powered device pipeline shall be done.

**5.3.9.3.5.1** The appropriate adapter shall be obtained from the facility or manufacturer, and high purge rates shall be put on each outlet.

**5.3.9.3.5.2** After the purge is started, it shall be rapidly interrupted several times until the purge produces no discoloration in a white cloth loosely held over the adapter during the purge.

**5.3.9.3.5.3** In order to avoid possible damage to the outlet and its components, the test shall not be conducted using any implement other than the correct adapter.

**5.3.9.3.6 Final Tie-In Test (Category 3 Gas-Powered Devices and Vacuum and Scavenging Systems).**

**5.3.9.3.6.1** Prior to the connection of any new piping in extensions or additions to an existing piping system, the final tests in 5.3.9.3 shall be successfully performed on the new work.

**5.3.9.3.6.2** Each joint in the final connection between the new work and the existing system shall be leak-tested, with the gas of system designation or vacuum at the normal operating pressure or vacuum, by means of a leak detectant that is safe for use with oxygen and does not contain ammonia.

**5.3.9.3.6.3** For gas-powered device piping, immediately after a final connection is made and leak-tested, the specific altered zone and components in the immediate zone or area that is downstream from the point or area of intrusion shall be purged per 5.3.9.3.5.

**5.3.9.3.7 Source Equipment Testing (Category 3 Gas-Powered Devices and Vacuum and Scavenging Systems).**

**5.3.9.3.7.1 General.** Source equipment checks for Category 3 gas-powered devices and vacuum and scavenging systems shall be performed following the installation of the interconnecting pipelines, accessories, and source equipment.

**5.3.9.3.7.2 Use of Source Equipment for Distribution Piping Tests.** Where the source equipment and system gas or vacuum is used for testing of the distribution piping, the source equipment shall be checked out and placed in operation prior to testing the distribution piping.

**5.3.9.3.7.3 Compliance with Manufacturer's Instructions.** The source equipment for a Category 3 gas-powered device system(s), vacuum system(s), and scavenging system(s) shall be checked

out and placed in operation according to the manufacturer's instructions.

**5.3.10 Compressed Gas Cylinders and Containers.**

**5.3.10.1** Only cylinders and containers constructed, tested, and maintained in accordance with U.S. Department of Transportation specifications and regulations shall be permitted to be used.

**5.3.10.2** Cylinder contents shall be identified by attached labels or stencils naming the contents in accordance with CGA C-7, *Guide to the Preparation of Precautionary Labeling and Marking of Compressed Gas Containers*.

**5.3.10.3** The contents of cylinders and containers shall be verified prior to use.

**5.3.10.4** Labels shall not be defaced, altered, or removed, and connecting fittings shall not be modified.

**5.3.11 Labeling and Identification.**

**5.3.11.1 Pipe Labeling.**

**5.3.11.1.1** Piping, both exposed and concealed, shall be labeled by stenciling or adhesive markers that identify the system.

**5.3.11.1.2** Pipe labels shall show the name of the gas/vacuum system or its chemical symbol.

**5.3.11.1.3** Where positive pressure gas piping systems operate at nonstandard pressures, the pipe labels shall also include the nonstandard operating pressure in addition to the name or symbol of the gas.

**5.3.11.1.4** Pipe labels shall be located as follows:

- (1) At intervals of not more than 6.1 m (20 ft)
- (2) At least once in or above every room
- (3) On both sides of walls or partitions penetrated by the piping
- (4) At least once in every story height on risers

**5.3.11.2 Identification of Shutoff Valves.** Shutoff valves shall be identified with the following information:

- (1) Name or chemical symbol for the specific system
- (2) Name of the room(s) or area(s) served
- (3) Caution to not close (or open) the valve except in an emergency

**5.3.11.3 Identification of Outlets and Inlets.** Outlets and inlets shall be identified as to the name or chemical symbol for the specific gas, vacuum, or scavenging provided.

**5.3.12\* System Use and Instructions.**

**5.3.12.1 Prohibited System Interconnections.**

**5.3.12.1.1** Two or more systems for Category 3 medical gas, gas-powered device gas, or vacuum and scavenging shall not be interconnected for testing or any other reason.

**5.3.12.1.2** Leak testing shall be accomplished by separately charging and testing each individual piping system.

**5.3.12.2 Changes in System Use.**

**5.3.12.2.1** Where a Category 3 positive pressure gas piping distribution system originally used or constructed for use at one pressure, or for one gas, is converted for operation at another pressure, or for another gas, all provisions and requirements of Section 5.3 shall apply.

**5.3.12.2.2** Piping for Category 3 gas-powered devices or Category 3 vacuum shall not be permitted to be converted for use as a Category 3 medical gas piping system for oxygen or nitrous oxide.

### 5.3.12.3 System and Equipment Manufacturer's Instructions.

5.3.12.3.1 The installation of individual components shall be made in accordance with the system or equipment manufacturer's instructions.

5.3.12.3.2 Such instructions shall include directions and information deemed necessary by the manufacturer for attaining proper operation, testing, and maintenance of the system.

5.3.12.3.3 Copies of the manufacturer's instructions shall be left with the system owner.

### 5.3.13 Operation and Management of Category 3 Systems.

5.3.13.1 Precautions for handling cylinders shall be in accordance with Chapter 11.

#### 5.3.13.2 Special Precautions for the Use of Category 3 Gas and Vacuum Piping Systems.

5.3.13.2.1 Category 3 gas piping systems shall not be used for the distribution of flammable anesthetic gases.

5.3.13.2.2 Piping systems for Category 3 gases shall not be used as grounding electrodes.

5.3.13.2.3 Category 3 vacuum piping shall not be used for vacuum steam condensate return or other nonmedical vacuum applications.

5.3.13.2.4 Every Category 3 facility shall establish a procedure for manually turning off the gas supply at the cylinder valves at the end of each work day.

5.3.13.2.5 Emergency shutoff valves or remote actuators shall not be used to turn off the gas supply at the end of the work day.

5.3.13.3 Category 3 Gas and Vacuum Systems Identification and Warning Signs. The labeling and identification of Category 3 gas and vacuum systems shall comply with the requirements of 5.3.11.

#### 5.3.13.4 Category 3 Gas and Vacuum Systems Maintenance and Record Keeping.

5.3.13.4.1 Permanent records of all tests required by Section 5.3 shall be maintained on-site in the organization's files.

5.3.13.4.2 A periodic testing procedure for Category 3 gas and vacuum systems and related alarm systems shall be implemented.

5.3.13.4.3 Whenever modifications are made that breach the pipeline, any necessary installer and verification test specified in 5.3.9 shall be conducted on the downstream portions of the medical gas piping system.

5.3.13.4.4 A maintenance program shall be established for the following:

- (1) Relief valves in accordance with applicable codes or manufacturer's recommendation
- (2) Drive gas supply system in accordance with manufacturer's recommendations
- (3) Vacuum source equipment and accessories in accordance with manufacturer's recommendations
- (4) Vacuum piping system and the secondary equipment attached to vacuum station inlets to ensure the continued good performance of the entire vacuum system
- (5) Scavenging systems to ensure performance

5.3.13.4.5 An audible and visual alarm indicator(s) shall meet the following requirements:

- (1) It shall be periodically tested to determine that it is functioning properly.
- (2) The records of the test shall be maintained until the next test is performed.

## Chapter 6 Electrical Systems

### 6.1\* Applicability.

6.1.1 This chapter shall apply to new health care facilities as specified in Section 1.3.

6.1.2 The following paragraphs of this chapter shall apply to new and existing health care facilities:

- (1) 6.3.2.2.4.2
- (2) 6.3.2.2.6.1
- (3) 6.3.2.2.6.2(F)
- (4) 6.3.2.2.8.5(B) (2), (3), and (4)
- (5) 6.3.2.2.8.7
- (6) 6.3.4
- (7) 6.4.1.1.17.5
- (8) 6.4.2.2.6.2(C)
- (9) 6.4.2.2.6.3
- (10) 6.4.4
- (11) 6.5.4
- (12) 6.6.2.2.3.2
- (13) 6.6.3.1
- (14) 6.6.4

6.1.3 Paragraph 6.3.2.2.2.3 shall apply only to existing facilities.

### 6.2 Nature of Hazards.

#### 6.2.1\* Fire and Explosions.

#### 6.2.2 Shock. (Reserved)

#### 6.2.3 Thermal. (Reserved)

### 6.3 Electrical System.

6.3.1 Sources. Each hospital appliance requiring electrical line power for operation shall be supported by power sources and distribution systems that provide power adequate for each service.

#### 6.3.1.1 Power/Utility Company. (Reserved)

#### 6.3.1.2 On-Site Generator Set. (Reserved)

#### 6.3.2 Distribution.

6.3.2.1 Electrical Installation. Installation shall be in accordance with *NFPA 70, National Electrical Code*.

6.3.2.1.1 Distribution system arrangements shall be designed to minimize interruptions to the electrical systems due to internal failures by the use of adequately rated equipment.

#### 6.3.2.2\* All Patient Care Rooms.

6.3.2.2.1\* Regular voltage wiring shall comply with the requirements in 6.3.2.2.1.1 through 6.3.2.2.1.4.

##### 6.3.2.2.1.1\* Circuits.

(A) Branch circuits serving a given patient bed location shall be fed from not more than one normal branch-circuit distribution panel.

(B) When required, branch circuits serving a given patient bed location shall be permitted to be fed from more than one critical branch-circuit distribution panel.

6.3.2.2.1.2 Critical Care Areas. Critical care areas shall be served by circuits from a critical branch panel(s) served from a single automatic transfer switch and a minimum of one circuit served by the normal power distribution system or by a system originating from a second critical branch automatic transfer switch.

**6.3.2.2.1.3 Access to Overcurrent Protective Devices.**

(A) Only authorized personnel shall have access to overcurrent protective devices serving Category 1 and Category 2 rooms.

(B) Overcurrent protective devices serving Category 1 and Category 2 rooms shall not be permitted to be located in public access spaces.

(C) Where used in locations such as in critical care areas, isolated power panels shall be permitted in those locations.

**6.3.2.2.1.4 Special-Purpose Outlets.** Branch circuits serving only special-purpose outlets or receptacles (e.g., portable X-ray receptacles) shall not be required to conform to the requirements of 6.3.2.2.1.2.

**6.3.2.2.2** Grounding requirements shall comply with the requirements in 6.3.2.2.2.1 through 6.3.2.2.2.4.

**6.3.2.2.2.1 Grounding Circuitry Integrity.** Grounding circuits and conductors in patient care rooms shall be installed in such a way that the continuity of other parts of those circuits cannot be interrupted nor the resistance raised above an acceptable level by the installation, removal, and replacement of any installed equipment, including power receptacles.

**6.3.2.2.2.2\* Reliability of Grounding.**

(A) Where used, the reliability of grounding circuits installed to a power receptacle in all patient care rooms shall be at least equivalent to that provided by an electrically continuous copper conductor of appropriate ampacity run from the receptacle to a grounding bus in the distribution panel.

(B) The grounding conductor shall conform to *NFPA 70, National Electrical Code*.

**6.3.2.2.2.3 Separate Grounding Conductor.** When existing construction does not have a separate grounding conductor, the continued use of the system shall be permitted, provided that it meets the performance requirements in 6.3.3.1.

**6.3.2.2.2.4 Metal Receptacle Boxes.** Where metal receptacle boxes are used, the performance of the connection between the receptacle grounding terminal and the metal box shall be equivalent to the performance provided by copper wire no smaller than 12 AWG.

**6.3.2.2.3\* Grounding Interconnects.** In patient care rooms supplied by the normal distribution system and any branch of the essential electrical system, the grounding system of the normal distribution system and that of the essential electrical system shall be interconnected.

**6.3.2.2.4 Protection Against Ground Faults.**

**6.3.2.2.4.1\* Equipment Protection.** The main and downstream ground-fault protective devices (where required) shall be coordinated as required in 6.3.2.5.

**6.3.2.2.4.2\* Personnel Protection.** If used, ground-fault circuit interrupters (GFCIs) shall be listed.

**6.3.2.2.5** Low-voltage wiring shall comply with either of the following:

- (1) Fixed systems of 30 V (dc or ac rms) or less shall be permitted to be ungrounded, provided that the insulation between each ungrounded conductor and the primary circuit, which is supplied from a conventionally grounded distribution system, is the same protection as required for the primary voltage.
- (2) A grounded low-voltage system shall be permitted, provided that load currents are not carried in the grounding conductors.

**6.3.2.2.6 Receptacles.**

**6.3.2.2.6.1\* Types of Receptacles.**

(A) Each power receptacle shall provide at least one, separate, highly dependable grounding pole capable of maintaining low-contact resistance with its mating plug, despite electrical and mechanical abuse.

(B) Special receptacles, such as the following, shall be permitted:

- (1) Four-pole units providing an extra pole for redundant grounding or ground continuity monitoring
- (2) Locking-type receptacles
- (3) Where required for reduction of electrical noise on the grounding circuit, receptacles in which the grounding terminals are purposely insulated from the receptacle yoke

**6.3.2.2.6.2 Minimum Number of Receptacles.** The number of receptacles shall be determined by the intended use of the patient care rooms in accordance with 6.3.2.2.6.2(A) through 6.3.2.2.6.2(E).

(A) **Receptacles for Patient Bed Locations in General Care Areas (Category 2).** Each patient bed location shall be provided with a minimum of eight receptacles.

(B) **Receptacles for Patient Bed Locations in Critical Care Areas (Category 1).** Each patient bed location shall be provided with a minimum of 14 receptacles.

(C) **Receptacles for Operating Rooms (Category 1).** Operating rooms shall be provided with a minimum of 36 receptacles.

(D) **Receptacles for Bathrooms or Toilets.** Receptacles shall not be required in bathrooms or toilet rooms.

(E) **Receptacles for Special Rooms.** Receptacles shall not be required in rooms where medical requirements mandate otherwise (e.g., certain psychiatric, pediatric, or hydrotherapy rooms).

(F) **Designated General Care Pediatric Locations.** Receptacles that are located within the patient rooms, bathrooms, playrooms, and activity rooms of pediatric units, other than nurseries, shall be listed tamper-resistant or shall employ a listed tamper-resistant cover.

**6.3.2.2.6.3 Polarity of Receptacles.** Each receptacle shall be wired in accordance with *NFPA 70, National Electrical Code*, to ensure correct polarity.

**6.3.2.2.6.4 Receptacles and Amperage.**

(A) Receptacles for use with 250-V, 50-A, and 60-A ac service shall be designed for use in locations where deep sedation or general anesthesia is administered and shall be so designed that the 60-A receptacle will accept either the 50-A or the 60-A plug.

(B) Fifty-ampere receptacles shall be designed so as not to accept the 60-A attachment plug.

(C) Both 50-A and 60-A receptacles shall be of the two-pole, three-wire design, with the third contact connecting to the grounding wire (green or green with yellow stripe) of the electrical system.

**6.3.2.2.6.5 Other Services Receptacles.** Receptacles provided for other services having different voltages, frequencies, or types on the same premises shall be of such design that attachment plugs and caps used in such receptacles cannot be connected to circuits of a different voltage, frequency, or type, but

shall be interchangeable within each classification and rating required for two-wire, 125-V, single-phase ac service.

#### 6.3.2.2.7 Special Grounding.

##### 6.3.2.2.7.1\* Use of Isolated Ground Receptacles.

(A) An isolated ground receptacle, if used, shall not defeat the purposes of the safety features of the grounding systems detailed herein.

(B) An isolated ground receptacle shall not be installed within a patient care vicinity.

**6.3.2.2.7.2 Patient Equipment Grounding Point.** A patient equipment grounding point comprising one or more grounding terminals or jacks shall be permitted in an accessible location in the patient care vicinity.

**6.3.2.2.7.3\* Special Grounding in Patient Care Rooms.** In addition to the grounding required to meet the performance requirements of 6.3.3.1, additional grounding shall be permitted where special circumstances so dictate.

#### 6.3.2.2.8 Wet Procedure Locations.

**6.3.2.2.8.1\*** Wet procedure locations shall be provided with special protection against electric shock.

**6.3.2.2.8.2** This special protection shall be provided as follows:

- (1) Power distribution system that inherently limits the possible ground-fault current due to a first fault to a low value, without interrupting the power supply
- (2)\*Power distribution system in which the power supply is interrupted if the ground-fault current does, in fact, exceed the trip value of a Class A GFCI

**6.3.2.2.8.3** Patient beds, toilets, bidets, and wash basins shall not be required to be considered wet procedure locations.

**6.3.2.2.8.4\*** Operating rooms shall be considered to be a wet procedure location, unless a risk assessment conducted by the health care governing body determines otherwise.

**6.3.2.2.8.5** In existing construction, the requirements of 6.3.2.2.8.1 shall not be required when a written inspection procedure, acceptable to the authority having jurisdiction, is continuously enforced by a designated individual at the hospital to indicate that equipment grounding conductors for 120-V, single-phase, 15-A and 20-A receptacles; equipment connected by cord and plug; and fixed electrical equipment are installed and maintained in accordance with *NFPA 70, National Electrical Code*, and the applicable performance requirements of this chapter.

(A) The procedure shall include electrical continuity tests of all required equipment, grounding conductors, and their connections.

(B) Fixed receptacles, equipment connected by cord and plug, and fixed electrical equipment shall be tested as follows:

- (1) When first installed
- (2) Where there is evidence of damage
- (3) After any repairs
- (4) At intervals not exceeding 6 months

**6.3.2.2.8.6** The use of an isolated power system (IPS) shall be permitted as a protective means capable of limiting ground-fault current without power interruption. When installed, such a power system shall conform to the requirements of 6.3.2.6.

**6.3.2.2.8.7\*** Operating rooms defined as wet procedure locations shall be protected by either isolated power or ground-fault circuit interrupters.

#### 6.3.2.2.9 Isolated Power.

**6.3.2.2.9.1** An isolated power system shall not be required to be installed in any patient care room, except as specified in 6.3.2.2.8.

**6.3.2.2.9.2** The system shall be permitted to be installed where it conforms to the performance requirements specified in 6.3.2.6.

#### 6.3.2.2.10 Essential Electrical Systems (EES).

**6.3.2.2.10.1** Critical care rooms (Category 1 Room) shall be served only by a Type I EES.

**6.3.2.2.10.2** General care rooms (Category 2 Room) shall be served by a Type I or Type II EES.

**6.3.2.2.10.3** A Type I EES serving a critical care room (Category 1 Room) shall be permitted to serve general care rooms (Category 2 Room) in the same facility.

**6.3.2.2.10.4** Basic care rooms shall not be required to be served by an EES.

**6.3.2.2.10.5** Rooms other than patient care rooms shall not be required to be served by an EES.

#### 6.3.2.2.11 Battery-Powered Lighting Units.

**6.3.2.2.11.1** One or more battery-powered lighting units shall be provided within locations where deep sedation and general anesthesia is administered.

**6.3.2.2.11.2** The lighting level of each unit shall be sufficient to terminate procedures intended to be performed within the operating room.

**6.3.2.2.11.3** The sensor for units shall be wired to the branch circuit(s) serving general lighting within the room.

**6.3.2.2.11.4** Units shall be capable of providing lighting for 1½ hours.

**6.3.2.2.11.5** Units shall be tested monthly for 30 seconds, and annually for 30 minutes.

**6.3.2.3 Laboratories.** Outlets with two to four receptacles, or an equivalent power strip, shall be installed every 0.5 m to 1.0 m (1.6 ft to 3.3 ft) in instrument usage areas, and either installation shall be at least 80 mm (3.15 in.) above the countertop.

#### 6.3.2.4 Other Nonpatient Areas. (Reserved)

#### 6.3.2.5 Ground-Fault Protection.

**6.3.2.5.1 Applicability.** The requirements of 6.3.2.5.2 shall apply to hospitals and other buildings housing critical care areas or utilizing life-support equipment and buildings that provide essential utilities or services for the operation of critical-care areas or electrical life-support equipment.

**6.3.2.5.2** When ground-fault protection is provided for operation of the service or feeder disconnecting means, an additional step of ground-fault protection shall be provided in the next level of feeder downstream toward the load.

**6.3.2.5.3** Ground-fault protection for operation of the service and feeder disconnecting means shall be fully selective such that the downstream device and not the upstream device shall open for downstream ground faults.

### 6.3.2.6\* Isolated Power Systems.

#### 6.3.2.6.1 Isolation Transformer.

6.3.2.6.1.1 The isolation transformer shall be listed and approved for the purpose.

6.3.2.6.1.2 The primary winding shall be connected to a power source so that it is not energized with more than 600 V (nominal).

(A) The neutral of the primary winding shall be grounded in an approved manner.

(B) If an electrostatic shield is present, it shall be connected to the reference grounding point.

6.3.2.6.1.3 Wiring of isolated power systems shall be in accordance with 517.62 of *NFPA 70, National Electrical Code*.

#### 6.3.2.6.2 Impedance of Isolated Wiring.

6.3.2.6.2.1\* The impedance (capacitive and resistive) to ground of either conductor of an isolated system shall exceed 200,000 ohms when installed. The installation at this point shall include receptacles but is not required to include lighting fixtures or components of fixtures. This value shall be determined by energizing the system and connecting a low-impedance ac milliammeter (0 to 1 mA scale) between the reference grounding point and either conductor in sequence. This test shall be permitted to be performed with the line isolation monitor (see 6.3.2.6.3) connected, provided that the connection between the line isolation monitor and the reference grounding point is open at the time of the test. After the test is made, the milliammeter shall be removed and the grounding connection of the line isolation monitor shall be restored. When the installation is completed, including permanently connected fixtures, the reading of the meter on the line isolation monitor, which corresponds to the unloaded line condition, shall be made. This meter reading shall be recorded as a reference for subsequent line impedance evaluation. This test shall be conducted with no phase conductors grounded.

6.3.2.6.2.2 An approved capacitance suppressor shall be permitted to be used to improve the impedance of the permanently installed isolated system; however, the resistive impedance to ground of each isolated conductor of the system shall be at least 1 megohm prior to the connection of the suppression equipment. Capacitance suppressors shall be installed so as to prevent inadvertent disconnection during normal use.

#### 6.3.2.6.3 Line Isolation Monitor.

6.3.2.6.3.1\* In addition to the usual control and protective devices, each isolated power system shall be provided with an approved, continually operating line isolation monitor that indicates possible leakage or fault currents from either isolated conductor to ground.

6.3.2.6.3.2 The monitor shall be designed such that a green signal lamp, conspicuously visible in the area where the line isolation monitor is utilized, remains lighted when the system is adequately isolated from ground; and an adjacent red signal lamp and an audible warning signal (remote if desired) shall be energized when the total hazard current (consisting of possible resistive and capacitive leakage currents) from either isolated conductor to ground reaches a threshold value of 5.0 mA under normal line voltage conditions. The line isolation monitor shall not alarm for a fault hazard current of less than 3.7 mA.

6.3.2.6.3.3\* The line isolation monitor shall comply with either of the following:

- (1) It shall have sufficient internal impedance such that, when properly connected to the isolated system, the maximum internal current that will flow through the line isolation monitor, when any point of the isolated system is grounded, shall be 1 mA.
- (2) It shall be permitted to be of the low-impedance type such that the current through the line isolation monitor, when any point of the isolated system is grounded, will not exceed twice the alarm threshold value for a period not exceeding 5 milliseconds.

6.3.2.6.3.4\* An ammeter connected to indicate the total hazard current of the system (contribution of the fault hazard current plus monitor hazard current) shall be mounted in a plainly visible place on the line isolation monitor with the "alarm on" zone (total hazard current = 5.0 mA) at approximately the center of the scale. A line isolation monitor shall be located in the operating room.

6.3.2.6.3.5 Means shall be provided for shutting off the audible alarm while leaving the red warning lamp activated. When the fault is corrected and the green signal lamp is reactivated, the audible alarm-silencing circuit shall reset automatically, or an audible or distinctive visual signal shall indicate that the audible alarm is silenced.

6.3.2.6.3.6 A reliable test switch shall be mounted on the line isolation monitor to test its capability to operate (i.e., cause the alarms to operate and the meter to indicate in the "alarm on" zone). This switch shall transfer the grounding connection of the line isolation monitor from the reference grounding point to a test impedance arrangement connected across the isolated line; the test impedance(s) shall be of the appropriate magnitude to produce a meter reading corresponding to the rated total hazard current at the nominal line voltage, or to a lesser alarm hazard current if the line isolation monitor is so rated. The operation of this switch shall break the grounding connection of the line isolation monitor to the reference grounding point before transferring this grounding connector to the test impedance(s), so that making this test will not add to the hazard of a system in actual use; nor will the test include the effect of the line-to-ground stray impedance of the system. The test switch shall be of a self-restoring type.

6.3.2.6.3.7 The line isolation monitor shall not generate energy of sufficient amplitude or frequency, as measured by a physiological monitor with a gain of at least  $10^4$  with a source impedance of 1000 ohms connected to the balanced differential input of the monitor, to create interference or artifact on human physiological signals. The output voltage from the amplifier shall not exceed 30 mV when the gain is  $10^4$ . The impedance of 1000 ohms shall be connected to the ends of typical unshielded electrode leads that are a normal part of the cable assembly furnished with physiological monitors. A 60 Hz notch filter shall be used to reduce ambient interference, as is typical in physiological monitor design.

6.3.2.6.4 Identification of Conductors for Isolated (Ungrounded) Systems. The isolated conductors shall be identified in accordance with 517.160(a)(5) of *NFPA 70, National Electrical Code*.

### 6.3.3 Performance Criteria and Testing.

#### 6.3.3.1 Grounding System in Patient Care Rooms.

**6.3.3.1.1\* Grounding System Testing.** The effectiveness of the grounding system shall be determined by voltage measurements and impedance measurements.

**6.3.3.1.1.1** For new construction, the effectiveness of the grounding system shall be evaluated before acceptance.

**6.3.3.1.1.2** Small wall-mounted conductive surfaces not likely to become energized, such as surface-mounted towel and soap dispensers, mirrors, and so forth, shall not be required to be intentionally grounded or tested.

**6.3.3.1.1.3** Large metal conductive surfaces not likely to become energized, such as windows, door frames, and drains, shall not be required to be intentionally grounded or periodically tested.

**6.3.3.1.1.4\*** Whenever the electrical system has been altered or replaced, that portion of the system shall be tested.

**6.3.3.1.2 Reference Point.** The voltage and impedance measurements shall be taken with respect to a reference point, which shall be one of the following:

- (1) Reference grounding point (*see Chapter 3*)
- (2) Grounding point, in or near the room under test, that is electrically remote from receptacles (e.g., an all-metal cold-water pipe)
- (3) Grounding contact of a receptacle that is powered from a different branch circuit from the receptacle under test

#### 6.3.3.1.3\* Voltage Measurements.

**6.3.3.1.3.1** The voltage measurements shall be made under no-fault conditions between a reference point and exposed fixed electrical equipment with conductive surfaces in a patient care vicinity.

**6.3.3.1.3.2** The voltage measurements shall be made with an accuracy of  $\pm 20$  percent.

**6.3.3.1.3.3** Voltage measurements for faceplates of wiring devices shall not be required.

**6.3.3.1.4\* Impedance Measurements.** The impedance measurement shall be made with an accuracy of  $\pm 20$  percent.

**6.3.3.1.4.1** For new construction, the impedance measurement shall be made between the reference point and the grounding contact of 10 percent of all receptacles within the patient care vicinity.

**6.3.3.1.4.2** The impedance measurement shall be the ratio of voltage developed (either 60 Hz or dc) between the point under test and the reference point to the current applied between these two points.

**6.3.3.1.5 Test Equipment.** Electrical safety test instruments shall be tested periodically, but not less than annually, for acceptable performance.

**6.3.3.1.5.1** Voltage measurements specified in 6.3.3.1.3 shall be made with an instrument having an input resistance of 1000 ohms  $\pm 10$  percent at frequencies of 1000 Hz or less.

**6.3.3.1.5.2** The voltage across the terminals (or between any terminal and ground) of resistance-measuring instruments used in occupied patient care rooms shall not exceed 500 mV rms or 1.4 dc or peak to peak.

#### 6.3.3.1.6 Criteria for Acceptability for New Construction.

**6.3.3.1.6.1** The voltage limit shall be 20 mV.

**6.3.3.1.6.2** The impedance limit shall be 0.2 ohm for systems containing isolated ground receptacles and 0.1 ohm for all others.

#### 6.3.3.2 Receptacle Testing in Patient Care Rooms.

**6.3.3.2.1** The physical integrity of each receptacle shall be confirmed by visual inspection.

**6.3.3.2.2** The continuity of the grounding circuit in each electrical receptacle shall be verified.

**6.3.3.2.3** Correct polarity of the hot and neutral connections in each electrical receptacle shall be confirmed.

**6.3.3.2.4** The retention force of the grounding blade of each electrical receptacle (except locking-type receptacles) shall be not less than 115 g (4 oz).

#### 6.3.3.3 Isolated Power Systems.

**6.3.3.3.1 Patient Care Rooms.** If installed, the isolated power system shall be tested in accordance with 6.3.3.3.2.

**6.3.3.3.2 Line Isolation Monitor Tests.** The line isolation monitor (LIM) circuit shall be tested after installation, and prior to being placed in service, by successively grounding each line of the energized distribution system through a resistor whose value is  $200 \times V$  (ohms), where V equals measured line voltage. The visual and audible alarms (*see 6.3.2.6.3.2*) shall be activated.

**6.3.3.4 Ground-Fault Protection Testing.** When equipment ground-fault protection is first installed, each level shall be performance-tested to ensure compliance with 6.3.2.5.

#### 6.3.4\* Administration of Electrical System.

##### 6.3.4.1 Maintenance and Testing of Electrical System.

**6.3.4.1.1** Where hospital-grade receptacles are required at patient bed locations and in locations where deep sedation or general anesthesia is administered, testing shall be performed after initial installation, replacement, or servicing of the device.

**6.3.4.1.2** Additional testing of receptacles in patient care rooms shall be performed at intervals defined by documented performance data.

**6.3.4.1.3** Receptacles not listed as hospital-grade, at patient bed locations and in locations where deep sedation or general anesthesia is administered, shall be tested at intervals not exceeding 12 months.

**6.3.4.1.4** The LIM circuit shall be tested at intervals of not more than 1 month by actuating the LIM test switch (*see 6.3.2.6.3.6*). For a LIM circuit with automated self-test and self-calibration capabilities, this test shall be performed at intervals of not more than 12 months. Actuation of the test switch shall activate both visual and audible alarm indicators.

**6.3.4.1.5** After any repair or renovation to an electrical distribution system, the LIM circuit shall be tested in accordance with 6.3.3.3.2.

##### 6.3.4.2 Record Keeping.

###### 6.3.4.2.1\* General.

**6.3.4.2.1.1** A record shall be maintained of the tests required by this chapter and associated repairs or modification.



**6.3.4.2.1.2** At a minimum, the record shall contain the date, the rooms or areas tested, and an indication of which items have met, or have failed to meet, the performance requirements of this chapter.

**6.3.4.2.2 Isolated Power System (Where Installed).** A permanent record shall be kept of the results of each of the tests.

#### **6.4 Essential Electrical System Requirements — Type 1.**

##### **6.4.1 Sources (Type 1 EES).**

###### **6.4.1.1 On-Site Generator Set.**

**6.4.1.1.1\* Design Considerations.** Dual sources of normal power shall be considered but shall not constitute an alternate source of power as described in this chapter.

**6.4.1.1.1.1** Distribution system arrangements shall be designed to minimize interruptions to the electrical systems due to internal failures by the use of adequately rated equipment.

**6.4.1.1.1.2** The following factors shall be considered in the design of the distribution system:

- (1) Abnormal voltages, such as single phasing of three-phase utilization equipment; switching or lightning surges, or both; voltage reductions; and so forth
- (2) Capability of achieving the fastest possible restoration of any given circuit(s) after clearing a fault
- (3) Effects of future changes, such as increased loading or supply capacity, or both
- (4) Stability and power capability of the prime mover during and after abnormal conditions
- (5)\*Sequence reconnection of loads to avoid large current inrushes that trip overcurrent devices or overload the generator(s)
- (6) Bypass arrangements to allow testing and maintenance of system components that could not otherwise be maintained without disruption of important hospital functions
- (7) Effects of any harmonic currents on neutral conductors and equipment

**6.4.1.1.2** Current-sensing devices, phase and ground, shall be selected to minimize the extent of interruption to the electrical system due to abnormal current caused by overload or short circuits, or both.

**6.4.1.1.3** Generator load-shed circuits designed for the purpose of load reduction or for load priority systems shall not shed life safety branch loads, critical branch loads serving critical care areas, medical air compressors, medical-surgical vacuum pumps, the pressure maintenance (jockey) pump(s) for water-based fire protection systems, generator fuel pumps, or other generator accessories.

**6.4.1.1.4** Essential electrical systems shall have a minimum of the following two independent sources of power: a normal source generally supplying the entire electrical system and one or more alternate sources for use when the normal source is interrupted.

**6.4.1.1.5** Where the normal source consists of generating units on the premises, the alternate source shall be either another generating set or an external utility service.

**6.4.1.1.6 General.** Generator sets installed as an alternate source of power for essential electrical systems shall be designed to meet the requirements of such service.

**6.4.1.1.6.1** Type 1 and Type 2 essential electrical system power sources shall be classified as Type 10, Class X, Level 1 generator

sets per NFPA 110, *Standard for Emergency and Standby Power Systems*.

**6.4.1.1.6.2** Type 3 essential electrical system power sources shall be classified as Type 10, Class X, Level 2 generator sets per NFPA 110, *Standard for Emergency and Standby Power Systems*.

###### **6.4.1.1.7 Uses for Essential Electrical System.**

**6.4.1.1.7.1** The generating equipment used shall be either reserved exclusively for such service or normally used for other purposes of peak demand control, internal voltage control, load relief for the external utility, or cogeneration. If normally used for such other purposes, two or more sets shall be installed, such that the maximum actual demand likely to be produced by the connected load of the life safety and critical branches, as well as medical air compressors, medical-surgical vacuum pumps, electrically operated fire pumps, jockey pumps, fuel pumps, and generator accessories, shall be met by a multiple generator system, with the largest generator set out of service (not available). The alternate source of emergency power for illumination and identification of means of egress shall be the essential electrical system. The alternate power source for fire protection signaling systems shall be the essential electrical system.

**6.4.1.1.7.2** A single generator set that operates the essential electrical system shall be permitted to be part of the system supplying the other purposes as specified in 6.4.1.1.7.1, provided that any such use will not decrease the mean period between service overhauls to less than 3 years.

**6.4.1.1.7.3\*** Optional loads shall be permitted to be served by the essential electrical system generating equipment. Optional loads shall be served by their own transfer means, such that these loads shall not be transferred onto the generating equipment if the transfer will overload the generating equipment and shall be shed upon a generating equipment overload. Use of the generating equipment to serve optional loads shall not constitute “other purposes” as described in 6.4.1.1.7.1 and, therefore, shall not require multiple generator sets.

**6.4.1.1.7.4** Where optional loads include contiguous or same-site facilities not covered in this code, provisions shall be made to meet the requirements of NFPA 101, *Life Safety Code*; Article 700 of NFPA 70, *National Electrical Code*; and other applicable NFPA requirements for emergency egress under load-shed conditions.

###### **6.4.1.1.8 Work Space or Room.**

**6.4.1.1.8.1** The EPS shall be installed in a separate room for Level 1 installations. EPSS equipment shall be permitted to be installed in this room. [110:7.2.1]

(A) The room shall have a minimum 2-hour fire rating or be located in an adequate enclosure located outside the building capable of resisting the entrance of snow or rain at a maximum wind velocity required by local building codes. [110:7.2.1.1]

(B) The rooms, shelters, or separate buildings housing Level 1 or Level 2 EPSS equipment shall be designed and located to minimize the damage from flooding, including that caused by the following:

- (1) Flooding resulting from fire fighting
- (2) Sewer water backup
- (3) Similar disasters or occurrences [110:7.2.3]

**6.4.1.1.8.2** The EPS equipment shall be installed in a location that permits ready accessibility and a minimum of 0.9 m (36 in.) from the skid rails’ outermost point in the direction of

access for inspection, repair, maintenance, cleaning, or replacement. This requirement shall not apply to units in outdoor housings. [110:7.2.5]

**6.4.1.1.9\* Capacity and Rating.** The generator set(s) shall have sufficient capacity and proper rating to meet the maximum actual demand likely to be produced by the connected load of the essential electrical system(s).

**6.4.1.1.10 Load Pickup.** The energy converters shall have the required capacity and response to pick up and carry the load within the time specified in Table 4.1 (b) of NFPA 110, *Standard for Emergency and Standby Power Systems*, after loss of primary power.

**6.4.1.1.11 Maintenance of Temperature.** The EPS shall be heated as necessary to maintain the water jacket temperature determined by the EPS manufacturer for cold start and load acceptance for the type of EPSS. [110:5.3.1]

**6.4.1.1.12\* Heating, Cooling, and Ventilating.** With the EPS running at rated load, ventilation airflow shall be provided to limit the maximum air temperature in the EPS room to the maximum ambient air temperature required by the EPS manufacturer. [110:7.7.1]

**6.4.1.1.12.1** Consideration shall be given to all the heat emitted to the EPS equipment room by the energy converter, uninsulated or insulated exhaust pipes, and other heat-producing equipment. [110:7.7.1.1]

**6.4.1.1.12.2** Air shall be supplied to the EPS equipment for combustion. [110:7.7.2]

(A) For EPS supplying Level 1 EPSS, ventilation air shall be supplied directly from a source outside of the building by an exterior wall opening or from a source outside the building by a 2-hour fire-rated air transfer system. [110:7.7.2.1]

(B) For EPS supplying Level 1 EPSS, discharge air shall be directed outside the building by an exterior wall opening or to an exterior opening by a 2-hour fire-rated air transfer system. [110:7.7.2.2]

(C) Fire dampers, shutters, or other self-closing devices shall not be permitted in ventilation openings or ductwork for supply or return/discharge air to EPS equipment for Level 1 EPSS. [110:7.7.2.3]

**6.4.1.1.12.3** Ventilation air supply shall be from outdoors or from a source outside of the building by an exterior wall opening or from a source outside the building by a 2-hour fire-rated air transfer system. [110:7.7.3]

**6.4.1.1.12.4** Ventilation air shall be provided to supply and discharge cooling air for radiator cooling of the EPS when running at rated load. [110:7.7.4]

(A) Ventilation air supply and discharge for radiator-cooled EPS shall have a maximum static restriction of 125 Pa (0.5 in. of water column) in the discharge duct at the radiator outlet. [110:7.7.4.1]

(B) Radiator air discharge shall be ducted outdoors or to an exterior opening by a 2-hour rated air transfer system. [110:7.7.4.2]

**6.4.1.1.12.5** Motor-operated dampers, when used, shall be spring operated to open and motor closed. Fire dampers, shutters, or other self-closing devices shall not be permitted in ventilation openings or ductwork for supply or return/discharge air to EPS equipment for Level 1 EPSS. [110:7.7.5]

**6.4.1.1.12.6** The ambient air temperature in the EPS equipment room or outdoor housing containing Level 1 rotating equipment shall be not less than 4.5°C (40°F). [110:7.7.6]

**6.4.1.1.12.7** Units housed outdoors shall be heated as specified in 5.3.1 [of NFPA 110, *Standard for Emergency and Standby Power Systems*]. [110:7.7.7]

**6.4.1.1.12.8** Design of the heating, cooling, and ventilation system for the EPS equipment room shall include provision for factors including, but not limited to, the following:

- (1) Heat
- (2) Cold
- (3) Dust
- (4) Humidity
- (5) Snow and ice accumulations around housings
- (6) Louvers
- (7) Remote radiator fans
- (8) Prevailing winds blowing against radiator fan discharge air [110:7.7.8]

**6.4.1.1.13 Cranking Batteries.** Internal combustion engine cranking batteries shall be in accordance with the battery requirements of NFPA 110, *Standard for Emergency and Standby Power Systems*.

**6.4.1.1.14 Compressed Air Starting Devices.** Other types of stored energy starting systems (except pyrotechnic) shall be permitted to be used where recommended by the manufacturer of the prime mover and subject to approval of the authority having jurisdiction, under the following conditions:

- (1) Where two complete periods of cranking cycles are completed without replacement of the stored energy
- (2) Where a means for automatic restoration from the emergency source of the stored energy is provided
- (3) Where the stored energy system has the cranking capacity specified in 5.6.4.2.1 of NFPA 110, *Standard for Emergency and Standby Power Systems*
- (4) Where the stored energy system has a “black start” capability in addition to normal discharge capability [110:5.6.4.1.2]

**6.4.1.1.15 Fuel Supply.** The fuel supply for the generator set shall comply with Sections 5.5 and 7.9 of NFPA 110, *Standard for Emergency and Standby Power Systems*.

**6.4.1.1.16 Requirements for Safety Devices.**

**6.4.1.1.16.1 Internal Combustion Engines.** Internal combustion engines serving generator sets shall be equipped with the following:

- (1) Sensor device plus visual warning device to indicate a water-jacket temperature below that required in 6.4.1.1.11
- (2) Sensor devices plus visual pre-alarm warning device to indicate the following:
  - (a) High engine temperature (above manufacturer’s recommended safe operating temperature range)
  - (b) Low lubricating oil pressure (below manufacturer’s recommended safe operating range)
  - (c) Low water coolant level
- (3) Automatic engine shutdown device plus visual device to indicate that a shutdown took place due to the following:
  - (a) Overcrank (failed to start)
  - (b) Overspeed
  - (c) Low lubricating oil pressure
  - (d) Excessive engine temperature
- (4) Common audible alarm device to warn that one or more of the pre-alarm or alarm conditions exist

**6.4.1.1.16.2** Safety indications and shutdowns shall be in accordance with Table 6.4.1.1.16.2.

**6.4.1.1.17 Alarm Annunciator.** A remote annunciator that is storage battery powered shall be provided to operate outside of the generating room in a location readily observed by operating personnel at a regular work station (see 700.12 of NFPA 70, *National Electrical Code*). The annunciator shall be hard-wired to indicate alarm conditions of the emergency or auxiliary power source as follows:

- (1) Individual visual signals shall indicate the following:
  - (a) When the emergency or auxiliary power source is operating to supply power to load
  - (b) When the battery charger is malfunctioning

- (2) Individual visual signals plus a common audible signal to warn of an engine-generator alarm condition shall indicate the following:
  - (a) Low lubricating oil pressure
  - (b) Low water temperature (below that required in 6.4.1.1.11)
  - (c) Excessive water temperature
  - (d) Low fuel when the main fuel storage tank contains less than a 4-hour operating supply
  - (e) Overcrank (failed to start)
  - (f) Overspeed

**6.4.1.1.17.1\*** A remote, common audible alarm shall be provided as specified in 6.4.1.1.17.4 that is powered by the storage battery and located outside of the EPS service room at a work site observable by personnel. [110:5.6.6]

**6.4.1.1.17.2** An alarm-silencing means shall be provided, and the panel shall include repetitive alarm circuitry so that, after the audible alarm has been silenced, it reactivates after the fault condition has been cleared and has to be restored to its normal position to be silenced again. [110:5.6.6.1]

**6.4.1.1.17.3** In lieu of the requirement of 5.6.6.1 of NFPA 110, a manual alarm-silencing means shall be permitted that silences the audible alarm after the occurrence of the alarm condition, provided such means do not inhibit any subsequent alarms from sounding the audible alarm again without further manual action. [110:5.6.6.2]

**6.4.1.1.17.4** Individual alarm indication to annunciate any of the conditions listed in Table 6.4.1.1.16.2 shall have the following characteristics:

- (1) It shall be battery powered.
- (2) It shall be visually indicated.
- (3) It shall have additional contacts or circuits for a common audible alarm that signals locally and remotely when any of the itemized conditions occurs.
- (4) It shall have a lamp test switch(es) to test the operation of all alarm lamps.

**6.4.1.1.17.5** A centralized computer system (e.g., building automation system) shall not be permitted to be substituted for the alarm annunciator in 6.4.1.1.17 but shall be permitted to be used to supplement the alarm annunciator.

**6.4.1.2 Battery.** Battery systems shall meet all requirements of Article 700 of NFPA 70, *National Electrical Code*.

**6.4.2\* Distribution (Type 1 EES).**

**6.4.2.1 General Requirements.**

**6.4.2.1.1** Electrical characteristics of the transfer switches shall be suitable for the operation of all functions and equipment they are intended to supply.

**6.4.2.1.2\* Selective Coordination.**

**6.4.2.1.2.1** Overcurrent protective devices serving the essential electrical system shall selectively coordinate for the period of time that a fault's duration extends beyond 0.1 second.

**6.4.2.1.2.2** Selective coordination shall not be required as follows:

- (1) Between transformer primary and secondary overcurrent protective devices, where only one overcurrent protective device or set of overcurrent protective devices exists on the transformer secondary.
- (2) Between overcurrent protective devices of the same size (ampere rating) in series.

**Table 6.4.1.1.16.2 Safety Indications and Shutdowns**

Indicator Function (at Battery Voltage)	Level 1		
	CV	S	RA
(a) Overcrank	X	X	X
(b) Low water temperature	X	—	X
(c) High engine temperature pre-alarm	X	—	X
(d) High engine temperature	X	X	X
(e) Low lube oil pressure pre-alarm	X	—	X
(f) Low lube oil pressure	X	X	X
(g) Overspeed	X	X	X
(h) Low fuel main tank	X	—	X
(i) Low coolant level	X	O	X
(j) EPS supplying load	X	—	—
(k) Control switch not in automatic position	X	—	X
(l) High battery voltage	X	—	—
(m) Low cranking voltage	X	—	X
(n) Low voltage in battery	X	—	—
(o) Battery charger ac failure	X	—	—
(p) Lamp test	X	—	—
(q) Contacts for local and remote common alarm	X	—	X
(r) Audible alarm-silencing switch	—	—	X
(s) Low starting air pressure	X	—	—
(t) Low starting hydraulic pressure	X	—	—
(u) Air shutdown damper when used	X	X	X
(v) Remote emergency stop	—	X	—

CV: Control panel-mounted visual. S: Shutdown of EPS indication. RA: Remote audible. X: Required. O: Optional.

Notes:

- (1) Item (p) shall be provided, but a separate remote audible signal shall not be required when the regular work site in 5.6.6 of NFPA 110, *Standard for Emergency and Standby Power Systems*, is staffed 24 hours a day.
- (2) Item (b) is not required for combustion turbines.
- (3) Item (r) or (s) is required only where used as a starting method.
- (4) Item (j): EPS ac ammeter shall be permitted for this function.
- (5) All required CV functions shall be visually annunciated by a remote, common visual indicator.
- (6) All required functions indicated in the RA column shall be annunciated by a remote, common audible alarm as required in 5.6.5.2(4) of NFPA 110.
- (7) Item (i) requires a low gas pressure alarm on gaseous systems.
- (8) Item (b) must be set at 11°C (20°F) below the regulated temperature determined by the EPS manufacturer, as required in 5.3.1 of NFPA 110.

**6.4.2.1.3 Switch Rating.** The rating of the transfer switches shall be adequate for switching all classes of loads to be served and for withstanding the effects of available fault currents without contact welding.

**6.4.2.1.4 Automatic Transfer Switch.** Transfer of all loads shall be accomplished using an automatic transfer switch(es). Each automatic transfer switch of 600 V or less shall be listed for the purpose and approved for emergency electrical service (see NFPA 70, *National Electrical Code, Article 700.3*) as a complete assembly.

**6.4.2.1.5 Automatic Transfer Switch Features.**

**6.4.2.1.5.1 Source Monitoring.**

(A)\* Undervoltage-sensing devices shall be provided to monitor all ungrounded lines of the primary source of power as follows:

(1) When the voltage on any phase falls below the minimum operating voltage of any load to be served, the transfer switch shall automatically initiate engine start and the process of transfer to the emergency power supply (EPS).

(2)\*When the voltage on all phases of the primary source returns to within specified limits for a designated period of time, the process of transfer back to primary power shall be initiated. [110:6.2.2.1]

(B) Both voltage-sensing and frequency-sensing equipment shall be provided to monitor one ungrounded line of the EPS power. [110:6.2.2.2]

(C) Transfer to the EPS shall be inhibited until the voltage and frequency are within a specified range to handle loads to be served. [110:6.2.2.3]

(D) Sensing equipment shall not be required in the transfer switch, provided it is included with the engine control panel. [110:6.2.2.3.1]

(E) Frequency-sensing equipment shall not be required for monitoring the public utility source where used as an EPS, as permitted by 5.1.4 of NFPA 110, *Standard for Emergency and Standby Power Systems*. [110:6.2.2.3.2]

**6.4.2.1.5.2 Interlocking.** Mechanical interlocking or an approved alternate method shall prevent the inadvertent interconnection of the primary power supply and the EPS, or any two separate sources of power. [110:6.2.3]

**6.4.2.1.5.3\* Manual Operation.** Instruction and equipment shall be provided for safe manual nonelectric transfer in the event the transfer switch malfunctions. [110:6.2.4]

**6.4.2.1.5.4\* Time Delay on Starting of EPS.** A time-delay device shall be provided to delay starting of the EPS. The timer shall prevent nuisance starting of the EPS and possible subsequent load transfer in the event of harmless momentary power dips and interruptions of the primary source. [110:6.2.5]

**6.4.2.1.5.5 Time Delay at Engine Control Panel.** Time delays shall be permitted to be located at the engine control panel in lieu of in the transfer switches. [110:6.2.6]

**6.4.2.1.5.6 Time Delay on Transfer to EPS.** An adjustable time-delay device shall be provided to delay transfer and sequence load transfer to the EPS to avoid excessive voltage drop when the transfer switch is installed for Level 1 use. [110:6.2.7]

(A) **Time Delay Commencement.** The time delay shall commence when proper EPS voltage and frequency are achieved. [110:6.2.7.1]

(B) **Time Delay at Engine Control Panel.** Time delays shall be permitted to be located at the engine control panel in lieu of in the transfer switches. [110:6.2.7.2]

**6.4.2.1.5.7\* Time Delay on Retransfer to Primary Source.** An adjustable time-delay device with automatic bypass shall be provided to delay retransfer from the EPS to the primary source of power, and allow the primary source to stabilize before retransfer of the load. [110:6.2.8]

**6.4.2.1.5.8 Time Delay Bypass If EPS Fails.** The time delay shall be automatically bypassed if the EPS fails. [110:6.2.9]

(A) The transfer switch shall be permitted to be programmed for a manually initiated retransfer to the primary source to provide for a planned momentary interruption of the load. [110:6.2.9.1]

(B) If used, the arrangement in 6.2.9.1 of NFPA 110, *Standard for Emergency and Standby Power Systems*, shall be provided with a bypass feature to allow automatic retransfer in the event that the EPS fails and the primary source is available. [110:6.2.9.2]

**6.4.2.1.5.9 Time Delay on Engine Shutdown.** A minimum time delay of 5 minutes shall be provided for unloaded running of the EPS prior to shutdown to allow for engine cooldown. [110:6.2.10]

(A) The minimum 5-minute delay shall not be required on small (15 kW or less) air-cooled prime movers. [110:6.2.10.1]

(B) A time-delay device shall not be required, provided it is included with the engine control panel, or if a utility feeder is used as an EPS. [110:6.2.10.2]

**6.4.2.1.5.10 Engine Generator Exercising Timer.** A program timing device shall be provided to exercise the EPS as described in Chapter 8 of NFPA 110, *Standard for Emergency and Standby Power Systems*. [110:6.2.11]

(A) Transfer switches shall transfer the connected load to the EPS and immediately return to primary power automatically in case of the EPS failure. [110:6.2.11.1]

(B) Exercising timers shall be permitted to be located at the engine control panel in lieu of in the transfer switches. [110:6.2.11.2]

(C) A program timing device shall not be required in health care facilities that provide scheduled testing in accordance with NFPA 99, *Health Care Facilities Code*. [110:6.2.11.3]

**6.4.2.1.5.11 Test Switch.** A test means shall be provided on each automatic transfer switch (ATS) that simulates failure of the primary power source and then transfers the load to the EPS. [110:6.2.12]

**6.4.2.1.5.12\* Indication of Switch Position.** Two pilot lights with identification nameplates or other approved position indicators shall be provided to indicate the transfer switch position. [110:6.2.13]

**6.4.2.1.5.13 Motor Load Transfer.** Provisions shall be included to reduce currents resulting from motor load transfer if such currents could damage EPSS equipment or cause nuisance tripping of EPSS overcurrent protective devices. [110:6.2.14]

**6.4.2.1.5.14\* Isolation of Neutral Conductors.** Provisions shall be included for ensuring continuity, transfer, and isolation of the primary and the EPS neutral conductors wherever they are separately grounded to achieve ground-fault sensing. [110:6.2.15]

**6.4.2.1.5.15\* Nonautomatic Transfer Switch Features.** Switching devices shall be mechanically held and shall be operated by direct manual or electrical remote manual control. [110:6.2.16]

**(A) Interlocking.** Reliable mechanical interlocking, or an approved alternate method, shall prevent the inadvertent interconnection of the primary power source and the EPS. [110:6.2.16.1]

**(B) Indication of Switch Position.** Two pilot lights with identification nameplates, or other approved position indicators, shall be provided to indicate the switch position. [110:6.2.16.2]

**6.4.2.1.6 Nonautomatic Transfer Device Classification.** Nonautomatic transfer devices of 600 V or less shall be listed for the purpose and approved.

**6.4.2.1.7 Nonautomatic Transfer Device Features.**

**6.4.2.1.7.1 General.** Switching devices shall be mechanically held and shall be operated by direct manual or electrical remote manual control. [110:6.2.16]

**6.4.2.1.7.2 Interlocking.** Reliable mechanical interlocking, or an approved alternate method, shall prevent the inadvertent interconnection of the primary power source and the EPS. [110:6.2.16.1]

**6.4.2.1.7.3 Indication of Switch Position.** Two pilot lights with identification nameplates, or other approved position indicators, shall be provided to indicate the switch position. [110:6.2.16.2]

**6.4.2.1.8 Bypass-Isolation Switches.** Bypass-isolation switches shall be permitted for bypassing and isolating the transfer switch and installed in accordance with 6.4.2 through 6.4.3 and 6.4.4. [110:6.4.1]

**6.4.2.1.8.1 Bypass-Isolation Switch Rating.** The bypass-isolation switch shall have a continuous current rating and a current rating compatible with that of the associated transfer switch. [110:6.4.2]

**6.4.2.1.8.2 Bypass-Isolation Switch Classification.** Each bypass-isolation switch shall be listed for emergency electrical service as a completely factory-assembled and factory-tested apparatus. [110:6.4.3]

**6.4.2.1.8.3\* Operation.** With the transfer switch isolated or disconnected, the bypass-isolation switch shall be designed so it can function as an independent nonautomatic transfer switch and allow the load to be connected to either power source. [110:6.4.4]

**6.4.2.1.8.4 Reconnection of Transfer Switch.** Reconnection of the transfer switch shall be possible without a load interruption greater than the maximum time, in seconds, specified by the type of system. [110:6.4.5]

**6.4.2.2 Branches.**

**6.4.2.2.1\* General.**

**6.4.2.2.1.1** The essential electrical system shall be divided into the following three branches:

- (1) Life safety
- (2) Critical
- (3) Equipment

**6.4.2.2.1.2** The division between the branches shall occur at transfer switches where more than one transfer switch is required.

**6.4.2.2.1.3** Each branch shall be arranged for connection, within time limits specified in this chapter, to an alternate source of power following a loss of the normal source.

**6.4.2.2.1.4** The number of transfer switches to be used shall be based upon reliability, design, and load considerations.

**(A)** Each branch of the essential electrical system shall have one or more transfer switches.

**(B)** One transfer switch shall be permitted to serve one or more branches in a facility with a continuous load on the switch of 150 kVA (120 kW) or less.

**6.4.2.2.2 Feeders from Alternate Source.**

**6.4.2.2.2.1** A single feeder supplied by a local or remote alternate source shall be permitted to supply the essential electrical system to the point at which the life safety, critical, and equipment branches are separated.

**6.4.2.2.2.2** Installation of the transfer equipment shall be permitted at other than the location of the alternate source.

**6.4.2.2.3 Life Safety Branch.**

**6.4.2.2.3.1** The life safety branch shall be limited to circuits essential to life safety.

**6.4.2.2.3.2** The life safety branch shall supply power for lighting, receptacles, and equipment as follows:

- (1) Illumination of means of egress in accordance with NFPA 101, *Life Safety Code*
- (2) Exit signs and exit directional signs in accordance with NFPA 101, *Life Safety Code*
- (3)\*Hospital communications systems, where used for issuing instruction during emergency conditions
- (4) Generator set location as follows:
  - (a) Task illumination
  - (b) Battery charger for emergency battery-powered lighting unit(s)
  - (c) Select receptacles at the generator set location and essential electrical system transfer switch locations
- (5) Elevator cab lighting, control, communications, and signal systems
- (6) Electrically powered doors used for building egress
- (7) Fire alarms and auxiliary functions of fire alarm combination systems complying with NFPA 72, *National Fire Alarm and Signaling Code*

**6.4.2.2.3.3** Alarm and alerting systems (other than fire alarm systems) shall be connected to the life safety branch or critical branch.

**6.4.2.2.3.4** Loads dedicated to a specific generator, including the fuel transfer pump(s), ventilation fans, electrically operated louvers, controls, cooling system, and other generator accessories essential for generator operation, shall be connected to the life safety branch or the output terminals of the generator with overcurrent protective devices.

**6.4.2.2.3.5** No functions other than those in 6.4.2.2.3.2, 6.4.2.2.3.3, and 6.4.2.2.3.4 shall be connected to the life safety branch, except as specifically permitted in 6.4.2.2.3.

**6.4.2.2.4\* Critical Branch.**

**6.4.2.2.4.1** The critical branch shall be permitted to be subdivided into two or more branches.

**6.4.2.2.4.2** The critical branch shall supply power for task illumination, fixed equipment, select receptacles, and select power circuits serving the following areas and functions related to patient care:

- (1) Critical care areas that utilize anesthetizing gases, task illumination, select receptacles, and fixed equipment
- (2) Isolated power systems in special environments
- (3) Task illumination and select receptacles in the following:
  - (a) Patient care rooms, including infant nurseries, selected acute nursing areas, psychiatric bed areas (omit receptacles), and ward treatment rooms
  - (b) Medication preparation areas
  - (c) Pharmacy dispensing areas
  - (d) Nurses' stations (unless adequately lighted by corridor luminaires)
- (4) Additional specialized patient care task illumination and receptacles, where needed
- (5) Nurse call systems
- (6) Blood, bone, and tissue banks
- (7)\*Telephone equipment rooms and closets
- (8) Task illumination, select receptacles, and select power circuits for the following areas:
  - (a) General care beds with at least one duplex receptacle per patient bedroom, and task illumination as required by the governing body of the health care facility
  - (b) Angiographic labs
  - (c) Cardiac catheterization labs
  - (d) Coronary care units
  - (e) Hemodialysis rooms or areas
  - (f) Emergency room treatment areas (select)
  - (g) Human physiology labs
  - (h) Intensive care units
  - (i) Postoperative recovery rooms (select)
- (9) Additional task illumination, receptacles, and select power circuits needed for effective facility operation, including single-phase fractional horsepower motors, which are permitted to be connected to the critical branch

#### **6.4.2.2.5 Equipment Branch.**

**6.4.2.2.5.1 General.** The equipment branch shall be connected to equipment described in 6.4.2.2.5.3 through 6.4.2.2.5.4.

#### **6.4.2.2.5.2 Connection to Alternate Power Source.**

(A) The equipment branch shall be installed and connected to the alternate power source, such that equipment described in 6.4.2.2.5.3 is automatically restored to operation at appropriate time-lag intervals following the energizing of the life safety and critical branches.

(B) The arrangement of the connection to the alternate power source shall also provide for the subsequent connection of equipment described in 6.4.2.2.5.4.

#### **6.4.2.2.5.3\* Equipment for Delayed-Automatic Connection.**

(A) The following equipment shall be permitted to be arranged for delayed-automatic connection to the alternate power source:

- (1) Central suction systems serving medical and surgical functions, including controls, with such suction systems permitted to be placed on the critical branch
- (2) Sump pumps and other equipment required to operate for the safety of major apparatus, including associated control systems and alarms

- (3) Compressed air systems serving medical and surgical functions, including controls, with such air systems permitted to be placed on the critical branch
- (4) Smoke control and stair pressurization systems
- (5) Kitchen hood supply or exhaust systems, or both, if required to operate during a fire in or under the hood
- (6) Supply, return, and exhaust ventilating systems for the following:
  - (a) Airborne infectious/isolation rooms
  - (b) Protective environment rooms
  - (c) Exhaust fans for laboratory fume hoods
  - (d) Nuclear medicine areas where radioactive material is used
  - (e) Ethylene oxide evacuation
  - (f) Anesthetic evacuation

(B) Where delayed-automatic connection is not appropriate, the ventilation systems specified in 6.4.2.2.5.3(A) (6) shall be permitted to be placed on the critical branch.

**6.4.2.2.5.4\* Equipment for Delayed-Automatic or Manual Connection.** The following equipment shall be permitted to be arranged for either delayed-automatic or manual connection to the alternate power source (*also see A.6.4.2.2.5.3*):

- (1) Heating equipment used to provide heating for operating, delivery, labor, recovery, intensive care, coronary care, nurseries, infection/isolation rooms, emergency treatment spaces, and general patient rooms; and pressure maintenance (jockey or make-up) pump(s) for water-based fire protection systems
- (2)\*Heating of general patient rooms during disruption of the normal source shall not be required under any of the following conditions:
  - (a) Outside design temperature is higher than  $-6.7^{\circ}\text{C}$  ( $+20^{\circ}\text{F}$ )
  - (b) Outside design temperature is lower than  $-6.7^{\circ}\text{C}$  ( $+20^{\circ}\text{F}$ ), where a selected room(s) is provided for the needs of all confined patients [then only such room(s) need be heated].
- (3) Elevator(s) selected to provide service to patient, surgical, obstetrical, and ground floors during interruption of normal power
- (4) Supply, return, and exhaust ventilating systems for surgical and obstetrical delivery suites, intensive care, coronary care, nurseries, and emergency treatment spaces
- (5) Hyperbaric facilities
- (6) Hypobaric facilities
- (7) Autoclaving equipment, which is permitted to be arranged for either automatic or manual connection to the alternate source
- (8) Controls for equipment listed in 6.4.2.2.4
- (9)\*Other selected equipment

#### **6.4.2.2.6 Wiring Requirements.**

**6.4.2.2.6.1\* Separation from Other Circuits.** The life safety branch and critical branch shall be kept independent of all other wiring and equipment.

**6.4.2.2.6.2 Receptacles.** The requirements for receptacles shall comply with 6.4.2.2.6.2(A), 6.4.2.2.6.2(B), and 6.4.2.2.6.2(C).

(A) The number of receptacles on a single branch circuit for areas described in 6.4.2.2.3.3(8) shall be minimized to limit the effects of a branch-circuit outage.

(B) Branch-circuit overcurrent devices shall be readily accessible to authorized personnel.

(C)\* The electrical receptacles or the cover plates for the electrical receptacles supplied from the life safety and critical branches shall have a distinctive color or marking so as to be readily identifiable.

**6.4.2.2.6.3 Switches.** Switches of all types shall be permitted in the lighting circuits connected to the essential electrical system that do not serve as the illumination of egress as required by NFPA 101, *Life Safety Code*.

**6.4.2.2.6.4 Mechanical Protection of the Life Safety and Critical Branches.** The wiring of the life safety and critical branches shall be mechanically protected by *raceways*, as defined in NFPA 70, *National Electrical Code*.

**6.4.2.2.6.5** Flexible power cords of appliances or other utilization equipment connected to the life safety and critical branches shall not be required to be enclosed in raceways.

**6.4.2.2.6.6** Secondary circuits of transformer-powered communication or signaling systems shall not be required to be enclosed in raceways unless otherwise specified by Chapters 7 or 8 of NFPA 70, *National Electrical Code*.

### 6.4.3 Performance Criteria and Testing (Type 1 EES).

**6.4.3.1 Source.** The life safety and critical branches shall be installed and connected to the alternate power source specified in 6.4.1.1.4 and 6.4.1.1.5 so that all functions specified herein for the life safety and critical branches are automatically restored to operation within 10 seconds after interruption of the normal source.

#### 6.4.3.2 Transfer Switches.

**6.4.3.2.1** All ac-powered support and accessory equipment necessary to the operation of the EPS shall be supplied from the load side of the automatic transfer switch(es), or the output terminals of the EPS, ahead of the main EPS overcurrent protection, as necessary, to ensure continuity of the EPSS operation and performance. [110:7.12.5]

**6.4.3.2.2** The essential electrical system shall be served by the normal power source, except when the normal power source is interrupted or drops below a predetermined voltage level. Settings of the sensors shall be determined by careful study of the voltage requirements of the load.

**6.4.3.2.3** Failure of the normal source shall automatically start the alternate source generator after a short delay, as described in 6.4.2.1.5.4. When the alternate power source has attained a voltage and frequency that satisfies minimum operating requirements of the essential electrical system, the load shall be connected automatically to the alternate power source.

**6.4.3.2.4** Upon connection of the alternate power source, the loads comprising the life safety and critical branches shall be automatically re-energized. The load comprising the equipment system shall be connected either automatically after a time delay, as described in 6.4.2.1.5.6, or nonautomatically and in such a sequential manner as not to overload the generator.

**6.4.3.2.5** When the normal power source is restored, and after a time delay, as described in 6.4.2.1.5.7, the automatic transfer switches shall disconnect the alternate source of power and connect the loads to the normal power source. The alternate power source generator set shall continue to run unloaded for a preset time delay, as described in 6.4.2.1.5.9.

**6.4.3.2.6** If the emergency power source fails and the normal power source has been restored, retransfer to the normal source of power shall be immediate, bypassing the retransfer delay timer.

**6.4.3.2.7** If the emergency power source fails during a test, provisions shall be made to immediately retransfer to the normal source.

**6.4.3.2.8** Nonautomatic transfer switching devices shall be restored to the normal power source as soon as possible after the return of the normal source or at the discretion of the operator.

### 6.4.4 Administration (Type 1 EES).

#### 6.4.4.1 Maintenance and Testing of Essential Electrical System.

##### 6.4.4.1.1 Maintenance and Testing of Alternate Power Source and Transfer Switches.

**6.4.4.1.1.1 Maintenance of Alternate Power Source.** The generator set or other alternate power source and associated equipment, including all appurtenance parts, shall be so maintained as to be capable of supplying service within the shortest time practicable and within the 10-second interval specified in 6.4.1.1.10 and 6.4.3.1.

**6.4.4.1.1.2** The 10-second criterion shall not apply during the monthly testing of an essential electrical system. If the 10-second criterion is not met during the monthly test, a process shall be provided to annually confirm the capability of the life safety and critical branches to comply with 6.4.3.1.

**6.4.4.1.1.3** Maintenance shall be performed in accordance with NFPA 110, *Standard for Emergency and Standby Power Systems*, Chapter 8.

**6.4.4.1.1.4 Inspection and Testing.** Criteria, conditions, and personnel requirements shall be in accordance with 6.4.4.1.1.4(A) through 6.4.4.1.1.4(C).

(A)\* **Test Criteria.** Generator sets shall be tested 12 times a year, with testing intervals of not less than 20 days nor more than 40 days. Generator sets serving essential electrical systems shall be tested in accordance with NFPA 110, *Standard for Emergency and Standby Power Systems*, Chapter 8.

(B) **Test Conditions.** The scheduled test under load conditions shall include a complete simulated cold start and appropriate automatic and manual transfer of all essential electrical system loads.

(C) **Test Personnel.** The scheduled tests shall be conducted by competent personnel to keep the machines ready to function and, in addition, serve to detect causes of malfunction and to train personnel in operating procedures.

##### 6.4.4.1.2 Maintenance and Testing of Circuitry.

**6.4.4.1.2.1\* Circuit Breakers.** Main and feeder circuit breakers shall be inspected annually, and a program for periodically exercising the components shall be established according to manufacturer's recommendations.

**6.4.4.1.2.2 Insulation Resistance.** The resistance readings of main feeder insulation shall be taken prior to acceptance and whenever damage is suspected.

**6.4.4.1.3 Maintenance of Batteries.** Batteries for on-site generators shall be maintained in accordance with NFPA 110, *Standard for Emergency and Standby Power Systems*.

**6.4.4.2 Record Keeping.** A written record of inspection, performance, exercising period, and repairs shall be regularly maintained and available for inspection by the authority having jurisdiction.

## 6.5 Essential Electrical System Requirements — Type 2.

**6.5.1 Sources (Type 2 EES).** The requirements for sources for Type 2 essential electrical systems shall conform to those listed in 6.4.1.

### 6.5.2 Distribution (Type 2 EES).

**6.5.2.1 General.** The distribution requirements for Type 2 essential electrical systems shall conform to those listed in 6.4.2.1.

#### 6.5.2.1.1\* Selective Coordination.

**6.5.2.1.1.1** Overcurrent protective devices serving the essential electrical system shall selectively coordinate for the period of time that a fault's duration extends beyond 0.1 second.

**6.5.2.1.1.2** Selective coordination shall not be required as follows:

- (1) Between transformer primary and secondary overcurrent protective devices, where only one overcurrent protective device or set of overcurrent protective devices exists on the transformer secondary. [70:700.27]
- (2) Between overcurrent protective devices of the same size (ampere rating) in series. [70:700.27]

#### 6.5.2.2 Specific Requirements.

##### 6.5.2.2.1\* General.

**6.5.2.2.1.1** The number of transfer switches to be used shall be based upon reliability, design, and load considerations.

**6.5.2.2.1.2** Each branch of the essential electrical system shall have one or more transfer switches.

**6.5.2.2.1.3** One transfer switch shall be permitted to serve one or more branches in a facility with a continuous load on the switch of 150 kVA (120 kW) or less.

##### 6.5.2.2.2 Life Safety Branch.

**6.5.2.2.2.1** The life safety and critical branches shall supply power for lighting, receptacles, and equipment as follows:

- (1) Illumination of means of egress in accordance with NFPA 101, *Life Safety Code*
- (2) Exit signs and exit directional signs in accordance with NFPA 101, *Life Safety Code*
- (3) Alarm and alerting systems, including the following:
  - (a) Fire alarms
  - (b) Alarms required for systems used for the piping of non-flammable medical gases as specified in Chapter 5
- (4)\*Communications systems, where used for issuing instructions during emergency conditions
- (5) Sufficient lighting in dining and recreation areas to provide illumination to exit ways of a minimum of 5 ft-candles
- (6) Task illumination and select receptacles at the generator set location
- (7) Elevator cab lighting, control, communications, and signal systems

**6.5.2.2.2.2** No functions, other than those listed in 6.5.2.2.2.1(1) through (7), shall be connected to the life safety.

##### 6.5.2.2.3 Equipment Branch.

###### 6.5.2.2.3.1 General.

(A) The equipment branch shall be installed and connected to the alternate power source such that equipment listed in

6.5.2.2.3.2 is automatically restored to operation at appropriate time-lag intervals following the restoration of the life safety and equipment branches to operation.

(B) The equipment branch arrangement shall also provide for the additional connection of equipment listed in 6.5.2.2.3.3.

**6.5.2.2.3.2 AC Equipment for Nondelayed-Automatic Connection.** Generator accessories including, but not limited to, the transfer fuel pump, electrically operated louvers, and other generator accessories essential for generator operation shall be arranged for automatic connection to the alternate power source.

**6.5.2.2.3.3 Delayed-Automatic Connections to Equipment Branch.** The following equipment shall be permitted to be connected to the equipment branch and shall be arranged for delayed-automatic connection to the alternate power source:

- (1) Task illumination and select receptacles in the following:
  - (a) Patient care rooms
  - (b) Medication preparation areas
  - (c) Pharmacy dispensing areas
  - (d) Nurses' stations (unless adequately lighted by corridor luminaires)
- (2) Supply, return, and exhaust ventilating systems for airborne infectious isolation rooms
- (3) Sump pumps and other equipment required to operate for the safety of major apparatus and associated control systems and alarms
- (4) Smoke control and stair pressurization systems
- (5) Kitchen hood supply or exhaust systems, or both, if required to operate during a fire in or under the hood

**6.5.2.2.3.4\* Delayed-Automatic or Manual Connections to Equipment Branch.** The equipment in 6.5.2.2.3.4(A) and 6.5.2.2.3.4(B) shall be permitted to be connected to the equipment branch and shall be arranged for either delayed-automatic or manual connection to the alternate power source.

(A) **Heating Equipment to Provide Heating for General Patient Rooms.** Heating of general patient rooms during disruption of the normal source shall not be required under any of the following conditions:

- (1)\*The outside design temperature is higher than  $-6.7^{\circ}\text{C}$  ( $+20^{\circ}\text{F}$ ).
- (2) The outside design temperature is lower than  $-6.7^{\circ}\text{C}$  ( $+20^{\circ}\text{F}$ ) and, where a selected room(s) is provided for the needs of all confined patients, then only such room(s) need be heated.
- (3) The facility is served by a dual source of normal power. See A.6.4.1.1.1 for more information.

(B)\* **Elevator Service.** In instances where interruptions of power would result in elevators stopping between floors, throw-over facilities shall be provided to allow the temporary operation of any elevator for the release of passengers.

(C) **Optional Connections to the Equipment Branch.** Additional illumination, receptacles, and equipment shall be permitted to be connected only to the equipment branch.

(D) **Multiple Systems.** Where one switch serves multiple systems as permitted in 6.5.2.2, transfer for all loads shall be non-delayed automatic.

###### 6.5.2.2.4 Wiring Requirements.

**6.5.2.2.4.1\* Separation from Other Circuits.** The life safety and equipment branches shall be kept entirely independent of all other wiring and equipment.



**6.5.2.2.4.2\* Receptacles.** The electrical receptacles or the cover plates for the electrical receptacles supplied from the life safety and equipment branches shall have a distinctive color or marking so as to be readily identifiable.

**6.5.3 Performance Criteria and Testing (Type 2 EES).**

**6.5.3.1 Source.** The life safety and equipment branches shall be installed and connected to the alternate source of power specified in 6.4.1.1.4 and 6.4.1.1.5 so that all functions specified herein for the life safety and equipment branches are automatically restored to operation within 10 seconds after interruption of the normal source.

**6.5.3.2 Transfer Switches.** The essential electrical system shall be served by the normal power source until the normal power source is interrupted or drops below a predetermined voltage level. Settings of the sensors shall be determined by careful study of the voltage requirements of the load.

**6.5.3.2.1** Failure of the normal source shall automatically start the alternate source generator after a short delay, as described in 6.4.2.1.5.4. When the alternate power source has attained a voltage and frequency that satisfies minimum operating requirements of the essential electrical system, the load shall be connected automatically to the alternate power source.

**6.5.3.2.2** All ac-powered support and accessory equipment necessary to the operation of the EPS shall be supplied from the load side of the automatic transfer switch(es), or the output terminals of the EPS, ahead of the main EPS overcurrent protection to ensure continuity of the EPSS operation and performance. [110:7.1.12.5]

**6.5.3.2.3** Upon connection of the alternate power source, the loads comprising the life safety and equipment branches shall be automatically re-energized. The loads comprising the equipment branch shall be connected either automatically after a time delay, as described in 6.4.2.1.5.6, or nonautomatically and in such a sequential manner as not to overload the generator.

**6.5.3.2.4** When the normal power source is restored, and after a time delay as described in 6.4.2.1.5.7, the automatic transfer switches shall disconnect the alternate source of power and connect the loads to the normal power source. The alternate power source generator set shall continue to run unloaded for a preset time delay as described in 6.4.2.1.5.9.

**6.5.3.2.5** If the emergency power source fails and the normal power source has been restored, retransfer to the normal source of power shall be immediate, bypassing the retransfer delay timer.

**6.5.3.2.6** If the emergency power source fails during a test, provisions shall be made to immediately retransfer to the normal source.

**6.5.3.2.7** Nonautomatic transfer switching devices shall be restored to the normal power source as soon as possible after the return of the normal source or at the discretion of the operator.

**6.5.4 Administration (Type 2 EES).**

**6.5.4.1 Maintenance and Testing of Essential Electrical System.**

**6.5.4.1.1 Maintenance and Testing of Alternate Power Source and Transfer Switches.**

**6.5.4.1.1.1 Maintenance of Alternate Power Source.** The generator set or other alternate power source and associated equipment, including all appurtenance parts, shall be so maintained as

to be capable of supplying service within the shortest time practicable and within the 10-second interval specified in 6.4.1.1.7 and 6.4.3.1.

**6.5.4.1.1.2 Inspection and Testing.** Generator sets shall be inspected and tested in accordance with 6.4.4.1.1.3.

**6.5.4.1.2 Maintenance and Testing of Circuitry.** Circuitry shall be maintained and tested in accordance with 6.4.4.1.2.

**6.5.4.1.3 Maintenance of Batteries.** Batteries shall be maintained in accordance with 6.4.4.1.3.

**6.5.4.2 Record Keeping.** A written record of inspection, performance, exercising period, and repairs shall be regularly maintained and available for inspection by the authority having jurisdiction.

**6.6 Essential Electrical System Requirements — Type 3.**

**6.6.1 Sources (Type 3 EES).** The alternate source of power for the system shall be specifically designed for this purpose and shall be either a generator, battery system, or self-contained battery integral with the equipment.

**6.6.1.1** Generators shall conform to 6.4.1.1 and 6.4.1.1.6.2.

**6.6.1.2** Battery systems shall conform to 6.4.1.2.

**6.6.2 Distribution (Type 3 EES).**

**6.6.2.1 General.** The distribution requirements for Type 3 essential electrical systems shall conform to those listed in 6.4.2.1.

**6.6.2.1.1\* Selective Coordination.**

**6.6.2.1.1.1** Overcurrent protective devices serving the essential electrical system shall selectively coordinate for the period of time that a fault's duration extends beyond 0.1 second.

**6.6.2.1.1.2** Selective coordination shall not be required as follows:

- (1) Between transformer primary and secondary overcurrent protective devices, where only one overcurrent protective device or set of overcurrent protective devices exists on the transformer secondary. [70:700.27]
- (2) Between overcurrent protective devices of the same size (ampere rating) in series. [70:700.27]

**6.6.2.2 Specific Requirements.**

**6.6.2.2.1\* General.**

**6.6.2.2.2 Connection to the Essential Electrical System.** The system shall supply power for task illumination that is related to the safety of life and that is necessary for the safe cessation of procedures in progress.

**6.6.2.2.3 Wiring Requirements.**

**6.6.2.2.3.1 General.** The design, arrangement, and installation of the system shall be in accordance with *NFPA 70, National Electrical Code*.

**6.6.2.2.3.2\* Receptacles.** The cover plates for the electrical receptacles or the electrical receptacles themselves supplied from the life safety and critical branches shall have a distinctive color or marking so as to be readily identifiable.

**6.6.3 Performance Criteria and Testing (Type 3 EES).**

**6.6.3.1 Source.**

**6.6.3.1.1** The life safety and critical branches shall have an alternate source of power separate and independent from the normal source that will be effective for a minimum of 1½ hours after loss of the normal source.

**6.6.3.1.2** The life safety and critical branches shall be so arranged that, in the event of failure of the normal power source, the alternate source of power shall be automatically connected to the load within 10 seconds.

**6.6.3.2 Transfer Switches with Engine Generator Sets.**

**6.6.3.2.1** The operation of the equipment shall be arranged such that the load will be served by the normal source until the normal source is interrupted or when the voltage drops below the setting of the voltage-sensing device.

**6.6.3.2.2** The settings of the voltage-sensing relays shall be determined by careful study of the voltage requirements of the load.

**6.6.3.2.3** When the normal source is restored, and after a time delay as described in 6.4.2.1.5.7, the automatic transfer switch shall disconnect the alternate source of power and connect the loads to the normal power source.

**6.6.3.2.4** If the alternate power source fails and the normal power source has been restored, retransfer to the normal source of power shall be immediate.

**6.6.3.3 Transfer Switches with Battery System.**

**6.6.3.3.1** Failure of the normal source shall automatically transfer the load to the battery system.

**6.6.3.3.2** Retransfer to the normal source shall be automatic upon restoration of the normal source.

**6.6.4 Administration (Type 3 EES).**

**6.6.4.1 Maintenance and Testing.**

**6.6.4.1.1 Maintenance and Testing of Alternate Power Source and Transfer Switches.**

**6.6.4.1.1.1 Maintenance of Alternate Power Source.** The generator set or other alternate power source and associated equipment, including all appurtenance parts, shall be so maintained as to be capable of supplying service within the shortest time practicable and within the 10-second interval specified in 6.4.1.1.10 and 6.6.3.1.2.

**6.6.4.1.1.2 Inspection and Testing.** Generator sets shall be inspected and tested in accordance with 6.4.4.1.1.3.

**6.6.4.1.1.3 Stored Energy Power Source.** Maintenance and testing of stored energy power supply systems shall be in accordance with NFPA 111, *Standard on Stored Electrical Energy Emergency and Standby Power Systems*, Section 6.1 through 6.4.5.

**6.6.4.1.2 Maintenance and Testing Circuitry.** Circuitry shall be maintained and tested in accordance with 6.4.4.1.2.

**6.6.4.1.3 Maintenance of Batteries.** Batteries shall be maintained in accordance with 6.4.4.1.3.

**6.6.4.2 Record Keeping.** A written record of inspection, performance, exercising period, and repairs shall be regularly maintained and available for inspection by the authority having jurisdiction.

## Chapter 7 Information Technology and Communications Systems for Health Care Facilities

**7.1\* Applicability.** This chapter shall apply to information technology and communications systems in all health care facilities that provide services to human beings.

**7.2 Reserved.**

**7.3 Category 1 Systems.**

**7.3.1 Information Technology and Communications Systems Infrastructure.**

**7.3.1.1 Premises Distribution System (Fiber and Copper).**

**7.3.1.1.1** Cables and installation shall be in compliance with NFPA 70, *National Electrical Code*, and TIA/EIA 568-B.

**7.3.1.1.2** Distribution system cable labeling, record keeping, and alphanumeric schemes shall be in accordance with TIA/EIA 606-A.

**7.3.1.2\* Telecommunications Systems Spaces and Pathways.**

**7.3.1.2.1 Entrance Facility (EF).**

**7.3.1.2.1.1 General.** The entrance facility (EF) location shall be permitted to be combined with the telecommunications equipment room (TER).

**7.3.1.2.1.2** Not less than two physically separated service entrance pathways into this location shall be required.

**7.3.1.2.1.3 Remote Primary Data Center.**

(A) In a facility where the primary data center is located remotely, two EFs and redundant telecommunications service entrances shall be provided.

(B)\* Electronic storage with a minimum capacity to store all inpatient records shall be provided at the building.

**7.3.1.2.1.4 Location Requirements and Restrictions.**

(A) The EF shall be permitted to be located with the emergency room (ER). Where the EF is combined with the ER, the space and electrical power and cabling shall be added to the ER to accommodate the telecommunications service provider's space and access requirements.

(B) The EF shall be dedicated to the telecommunications function and related support facilities.

(C) Electrical equipment or fixtures (e.g., transformers, panelboards, conduit, wiring) that are not directly related to the support of the EF shall not be installed in or pass through the EF.

(D) Mechanical equipment and fixtures (e.g., water or drainage piping of any kind, ductwork, pneumatic tubing) that are not directly related to the support of the EF shall not be installed in, pass through, or enter the EF.

(E) Other underground utilities, such as electrical, water, gas, and sewer, shall not be located below the EF.

(F) The EF shall be located not less than 3.66 m (12 ft) from any permanent source of electromagnetic interference, such as medical imaging equipment, transformers, motors, variable frequency drives, induction heaters, arc welders, radio and radar systems, or other sources of electromagnetic interference.

(G) The EF shall be located in an area not subject to flooding and shall be as close as practicable to the building communications service entrance point.

**7.3.1.2.1.5 Power Requirements.**

(A) Circuits serving the EF shall be dedicated to serving the EF.

(B)\* Circuits serving equipment in the EF shall be connected to the critical power branch of the emergency electrical system.

(C) A minimum of one duplex receptacle served from normal power shall be provided on one wall of the EF for service and maintenance.

**7.3.1.2.1.6 Environmental Requirements.**

(A) Temperature and humidity in the EF shall be controlled in accordance with the manufacturer's equipment requirements.

(B) HVAC systems serving the EF shall be connected to the equipment branch of the essential electrical system.

(C)\* A positive pressure differential with respect to surrounding areas shall be provided.

**7.3.1.2.1.7 Fire Suppression Systems.** Sprinkler heads shall be provided with wire cages or shall be recessed to prevent accidental operation.

**7.3.1.2.2 Telecommunications Equipment Room (TER).**

**7.3.1.2.2.1 General.** The telecommunications equipment room (TER) houses the main networking equipment and shall be permitted to also house application servers and data storage devices that serve the health care facility if the TER is being utilized as a data center. In addition, central equipment for other communications systems shall be permitted to be housed in the TER.

**7.3.1.2.2.2\*** The TER shall be a separate space and shall not be used for any other purposes besides networking, data storage, and processing, except that the telecommunications entrance facility (TEF) can be combined with the TER space.

**7.3.1.2.2.3** Each facility shall have at least one TER space that meets the minimum requirements of this chapter.

**7.3.1.2.2.4 Working Space.** Working space about communications cabinets, racks, or other equipment shall be in accordance with 110.26(A) of *NFPA 70, National Electrical Code*.

**7.3.1.2.2.5 Location Requirements and Restrictions.**

(A) Electrical equipment or fixtures (e.g., transformers, panelboards, conduit, wiring) that are not directly related to the support of the TER shall not be installed in, pass through, or enter the TER.

(B) Any mechanical equipment or fixtures (e.g., water or drainage piping of any kind, ductwork, pneumatic tubing) not directly related to the support of the TER shall not be installed in, pass through, or enter the TER.

(C) The TER shall be located in a nonsterile area of the facility.

(D) In areas prone to hurricanes or tornados, the TER shall be located away from exterior curtain walls to prevent wind and water damage.

(E) The TER shall be located not less than 3.66 m (12 ft) from any permanent source of electromagnetic interference, such as medical imaging equipment, transformers, motors, variable frequency drives, induction heaters, arc welders, radio transmission systems, or other sources of electromagnetic interference.

(F) The TER shall be located or designed to avoid vibration from mechanical equipment or other sources.

**7.3.1.2.2.6 Security.** Access to the TER shall be restricted and controlled.

**7.3.1.2.2.7 Power Requirements.**

(A) Circuits serving the TER and the equipment within the TER shall be dedicated to serving the TER.

(B) Circuits serving fire alarm, medical gas alarms, elevator communications, and communications systems used for issuing instructions during emergency conditions (e.g., fireman's phone system) shall be connected to the life safety branch of the essential electrical system.

(C) Circuits serving other communications equipment in the TER shall be connected to the essential electrical system. This equipment shall include the telephone system, nurse call, staff assistance call, and code systems.

(D) A minimum of one duplex outlet shall be provided on each wall and shall be connected to normal power for service and maintenance.

(E) Consideration shall be given to the reliability of power supply to the HVAC equipment because of its important function within the TER.

**7.3.1.2.2.8 Environmental Requirements.**

(A) Temperature and humidity in the TER shall be controlled in accordance with the manufacturer's equipment requirements.

(B) HVAC systems serving the TER shall be connected to the equipment branch of the essential electrical system.

(C) A positive pressure differential with respect to surrounding areas shall be provided.

**7.3.1.2.3 Telecommunications Room (TR).**

**7.3.1.2.3.1 General.** A telecommunications room (TR) houses telecommunications equipment, cable terminations, and cross-connect cabling.

**7.3.1.2.3.2** Sufficient TRs shall be provided such that any data or communications outlet in the building can be reached without exceeding 90 m (292 ft) maximum pathway distance from the termination point in the TR to the outlet.

**7.3.1.2.3.3** A minimum of one TR shall be on each floor of the facility.

**7.3.1.2.3.4** A TR shall serve a maximum of 1858 m<sup>2</sup> (20,000 ft<sup>2</sup>) of usable space on a single floor.

**7.3.1.2.3.5 Working Space.** Working space about communications cabinets, racks, or other equipment shall be in accordance with 110.26(A) of *NFPA 70, National Electrical Code*.

**7.3.1.2.3.6 Location Requirements and Restrictions.**

(A) Switchboards, panelboards, transformers, and similar electrical equipment that are not directly related to the support of the TR shall not be installed in the TR.

(B) Any mechanical equipment or fixtures (e.g., water or drainage piping of any kind, ductwork, pneumatic tubing) not directly related to the support of the TR shall not be installed in, pass through, or enter the TR.

(C) In areas prone to hurricanes or tornados, TRs shall be located away from exterior curtain walls to prevent wind and water damage.

(D) The TR shall be located a minimum of 3.66 m (12 ft) from any permanent source of electromagnetic interference, such as medical imaging equipment, transformers, motors, variable frequency drives, induction heaters, arc welders, radio transmission systems, or other sources of electromagnetic interference.

**7.3.1.2.3.7 Security.** Access to TRs shall be restricted and controlled.

**7.3.1.2.3.8 Power Requirements.**

(A) Circuits serving the TR and the equipment within the TR shall be dedicated to serving the TR.

(B) Circuits serving the TR shall be connected to the critical power branch of the emergency electrical system.

(C) A minimum of one duplex receptacle shall be provided in each TR and shall be connected to normal power for service and maintenance.

#### 7.3.1.2.3.9 Environmental Requirements.

(A) Temperature and humidity in the TR shall be controlled in accordance with the manufacturer's equipment requirements.

(B) Sprinkler heads shall be provided with wire cages to prevent accidental discharge.

**7.3.1.2.3.10 Other Requirements.** Dropped ceilings shall not be installed in the TR.

#### 7.3.1.2.4 Cabling Pathways and Raceway Requirements.

**7.3.1.2.4.1 Backbone Distribution.** Redundant pathways shall be provided between the EF and TER.

**7.3.1.2.4.2** Conduits shall be provided for cabling in inaccessible ceiling spaces.

#### 7.3.1.2.5 Outside Plant (OSP) Infrastructure.

**7.3.1.2.5.1 General.** Outside plant (OSP) infrastructure consists of the conduits, vaults, and other pathways and cabling used to connect buildings on a campus and to provide services from off-campus service providers.

#### 7.3.1.2.5.2 Pathways.

(A) Dual telecommunications service entrance pathways shall be provided to the TEF.

(B) Service entrance pathways shall be a minimum of 6.1 m (20 ft) apart.

(C) Underground conduits for technology systems shall be a minimum of 0.61 m (2 ft) from underground steam and water piping if crossing perpendicularly, and a minimum of 1.83 m (6 ft) if parallel.

(D) Underground conduits for technology systems shall be a minimum of 0.61 m (2 ft) below grade.

#### 7.3.1.3 Antennas. (Reserved)

### 7.3.2 Voice, Data, Communications, and Cable Television Systems.

#### 7.3.2.1 Voice/Telecommunications. (Reserved)

#### 7.3.2.2 Local Area Networks (LANS). (Reserved)

#### 7.3.2.3 Wireless Local Area Network (LAN) Systems and Public Wifi Hot Spots. (Reserved)

#### 7.3.2.4 Wireless Voice Systems and In-Building Cellular Networks. (Reserved)

#### 7.3.2.5 UHF, VHF, 800 MHz, and 900 MHz Radio Communication Systems. (Reserved)

#### 7.3.2.6 Cable Television. (Reserved)

### 7.3.3 Other Communications Systems.

#### 7.3.3.1 Nurse Call Systems.

**7.3.3.1.1 General.** The nurse call systems shall communicate patient and staff calls for assistance and information in health care facilities. The nurse call systems shall be the audiovisual type and listed for the purpose.

**7.3.3.1.1.1** The nurse call systems shall provide for communication of patient and staff calls for assistance and information, medical device alarms, and patient safety and security alarms.

**7.3.3.1.1.2** Supplemental features shall be permitted to include call initiation to alphanumeric pagers and other wireless devices carried by health care facility staff.

**7.3.3.1.2 Patient Area Call Station.** Each patient bed location shall be provided with a calling device. Not more than two calling devices, serving adjacent beds, shall be served by a single audiovisual call station providing two-way voice communication.

**7.3.3.1.3 Signals.** Activation of a patient bed calling device shall cause visual signal activation in the corridor at the patient room door, the associated nursing station, the calling station, and associated nursing unit support areas, including medication, nourishment, charting, storage, and exam/treatment rooms and clean and soiled linen storage areas.

**7.3.3.1.4** Additional visual signals shall be provided at corridor intersections where individual patient door signals are not directly visible from the central nursing station.

**7.3.3.1.5** A visual signal indication shall be provided at each calling station indicating voice circuit operation.

**7.3.3.1.6 Emergency Call.** Each calling station shall be capable of initiating a visual and audible emergency signal, distinct from the regular nurse call signal, that can be turned off only at that station. The emergency call shall activate an annunciator at the nearest associated nursing station and a visual signal in the corridor at the patient room door and at other locations as directed by the facility.

**7.3.3.1.6.1** Emergency calling devices shall be provided at each inpatient toilet, bath, shower, or sitz bath and shall be accessible to a patient lying on the floor. A pull cord shall be permitted to be used for this access.

**7.3.3.1.6.2** Emergency calling devices shall be provided in outpatient and treatment areas where patients can be incapacitated.

**7.3.3.1.6.3** Emergency branches calling devices shall be provided in patient toilet rooms in imaging suites, renal dialysis units, and similar areas.

#### 7.3.3.1.7 Staff Emergency Assistance Call.

**7.3.3.1.7.1** An emergency assistance system for staff to summon additional assistance shall be provided in each operating, delivery, recovery, emergency, examination, treatment, and intermediate care area, and in critical care units, nurseries, special procedure rooms, cardiac catheterization rooms, stress test areas, triage, outpatient surgery, admission and discharge areas, and areas for psychiatric patients, including seclusion and security rooms, anterooms and toilet rooms that serve them, communal toilet and bathing facility rooms, and dining, activity, therapy, exam, and treatment rooms.

**7.3.3.1.7.2** Other communications systems that perform the same function shall be permitted.

**7.3.3.1.8 Emergency Resuscitation Alarm.** The call system shall include provisions for an emergency code resuscitation alarm to summon assistance from outside the unit for critical care, pre-op, recovery, and emergency units.

**7.3.3.1.9** In areas where patients are under constant visual surveillance, such as pre-op, recovery, and emergency units, the nurse call system shall be permitted to be limited to the staff emergency assistance call and the emergency resuscitation alarm. Two-way communication from the patient bed location shall not be required.

**7.3.3.1.10** A nurse call system shall be provided for geriatric, Alzheimer's, and other dementia units, and all hardware shall have tamper-resistant fasteners, provisions shall be made for removal or covering of call button outlets, and call cords or strings in excess of 152 mm (6 in.) shall not be permitted.

**7.3.3.1.11** A nurse call system shall not be required in psychiatric units, but, if one is included, all hardware shall have tamper-resistant fasteners, provisions shall be made for removal or covering of call button outlets, and control to limit unauthorized use shall be permitted.

**7.3.3.2** The staff emergency assistance system shall annunciate each call visibly and audibly in the clean workroom; in the soiled workroom; in medication, charting, clean linen storage, nourishment, equipment storage, and examination/treatment rooms, if provided; and at the nursing station of the associated nursing unit, with backup to another staffed area from which assistance can be summoned.

**7.3.3.3 Patient Tracking. (Reserved)**

**7.3.3.4 Equipment and Asset Tracking. (Reserved)**

**7.3.3.5 Staff and Visitor Tracking. (Reserved)**

**7.3.3.6 Wireless Phone and Paging Integration. (Reserved)**

**7.3.3.7 Patient and Equipment Monitoring Systems. (Reserved)**

**7.3.3.8 Clinical Information Systems. (Reserved)**

**7.3.3.9 Pharmacy. (Reserved)**

**7.3.3.10 Material Management Information Systems. (Reserved)**

**7.3.3.11 Electronic Medical Records and Dictation Systems. (Reserved)**

**7.3.3.12 Medical Imaging Systems. (Reserved)**

**7.3.3.13 Archiving Systems. (Reserved)**

**7.3.4 Security Systems.**

**7.3.4.1 Internet Protocol (IP) Security Cameras Systems. (Reserved)**

**7.3.4.2 Digital Video Recording. (Reserved)**

**7.3.4.3 Intrusion Detection Systems. (Reserved)**

**7.3.4.4 Sitewide Monitoring. (Reserved)**

**7.3.4.5 Access Control Systems. (Reserved)**

**7.3.4.6 ID Badging Systems Integrated with Point of Sales Systems. (Reserved)**

**7.3.4.7 Threat Protection Systems. (Reserved)**

**7.3.4.8 Parking Access Systems. (Reserved)**

**7.4 Category 2 Systems.**

**7.4.1 Information Technology and Communications Systems Infrastructure.**

**7.4.1.1** Requirements for information technology and communications systems infrastructure shall be in accordance with 7.3.1, except as specified in 7.4.1.1.1 and 7.4.1.1.2.

**7.4.1.1.1** HVAC systems serving the TEF, the TER, and TRS shall be connected to the essential electrical system.

**7.4.1.1.2** Redundant pathways and cabling for the backbone distribution system shall not be required.

**7.4.2 Voice, Data, Communications, and Cable Television Systems.**

**7.4.2.1 Voice/Telecommunications. (Reserved)**

**7.4.2.2 Local Area Networks (LANs). (Reserved)**

**7.4.2.3 Wireless Local Area Network (LAN) Systems and Public Wifi Hot Spots. (Reserved)**

**7.4.2.4 Wireless Voice Systems and In-Building Cellular Networks. (Reserved)**

**7.4.2.5 Cable Television. (Reserved)**

**7.4.3 Other Communications Systems.**

**7.4.3.1 Nurse Call Systems.**

**7.4.3.1.1 General.** The nurse call system shall communicate patient and staff calls for assistance and information in health care facilities. The nurse call system shall be the audiovisual or visual type (using light and tone signals only to communicate calls) and shall be listed for the purpose.

**7.4.3.1.1.1** The nurse call system shall provide for communication of patient and staff calls for assistance, medical device alarms, and patient safety and security alarms.

**7.4.3.1.1.2** Supplemental features shall be permitted to be included, such as call initiation to alphanumeric pagers and other wireless devices carried by health care facility staff.

**7.4.3.1.2 Patient Area Call Station.**

**7.4.3.1.2.1** Each patient bed location shall be provided with a calling device.

**7.4.3.1.2.2** Not more than two calling devices, serving adjacent beds, shall be served by a single call station.

**7.4.3.1.3 Signals.** Activation of a patient bed calling device shall cause visual signal activation in the corridor at the patient room door, the associated nursing station, the calling station, and associated nursing unit support areas, including medication, nourishment, charting, storage, and exam/treatment rooms and clean and soiled linen storage areas.

**7.4.3.1.4** Additional visual signals shall be provided at corridor intersections where individual patient door signals are not directly visible from the central nursing station.

**7.4.3.1.5 Emergency Call.** Each calling station shall be capable of a initiating visual and audible emergency signal, distinct from the regular nurse call signal, that can be turned off only at that station. The emergency call shall activate an annunciator at the nearest associated nursing station, a visual signal in the corridor at the patient room door, and other locations as directed by the facility.

**7.4.3.1.5.1** Emergency calling devices shall be provided at each inpatient toilet, bath, shower, or sitz bath and shall be accessible to a patient lying on the floor. A pull cord shall be permitted to be used for this access.

**7.4.3.1.5.2** Emergency calling devices shall be provided in outpatient and treatment areas where patients can be incapacitated.

**7.4.3.1.5.3** Emergency calling devices shall be provided in patient toilet rooms in imaging suites, renal dialysis units, and similar areas.

**7.4.3.1.6 Staff Emergency Assistance Call.**

**7.4.3.1.6.1** An emergency assistance system for staff to summon additional assistance shall be provided in each outpatient surgery, admission and discharge areas, and areas for psychiatric patients, including seclusion and security rooms, ante-rooms and toilet rooms that serve them, communal toilet and bathing facility rooms, and dining, activity, therapy, exam, and treatment rooms.

**7.4.3.1.6.2** Other communications systems that perform the same function shall be permitted.

**7.4.3.1.7** A nurse call system shall be provided for geriatric, Alzheimer's, and other dementia units, and all hardware shall have tamper-resistant fasteners, provisions shall be made for removal or covering of call button outlets, and call cords or strings in excess of 15.24 cm (6 in.) shall not be permitted.

**7.4.3.1.8** A nurse call system shall not be required in psychiatric units, but if one is included, all hardware shall have tamper-resistant fasteners, provisions shall be made for removal or covering of call button outlets, and control to limit unauthorized use shall be permitted.

**7.4.3.2** The staff emergency assistance system shall annunciate each call visibly and audibly in the clean workroom; in the soiled workroom; in medication, charting, clean linen storage, nourishment, equipment storage, and examination/treatment rooms, if provided; and at the nursing station of the associated nursing unit, with backup to another staffed area from which assistance can be summoned.

**7.4.3.3 Patient Tracking. (Reserved)**

**7.4.3.4 Equipment and Asset Tracking. (Reserved)**

**7.4.3.5 Staff and Visitor Tracking. (Reserved)**

**7.4.3.6 Wireless Phone and Paging Integration. (Reserved)**

**7.4.3.7 Patient and Equipment Monitoring Systems. (Reserved)**

**7.4.3.8 Material Management Information Systems. (Reserved)**

**7.4.3.9 Electronic Medical Records and Dictation Systems. (Reserved)**

**7.4.3.10 Medical Imaging Systems. (Reserved)**

**7.4.3.11 Archiving Systems. (Reserved)**

**7.4.4 Security Systems.**

**7.4.4.1 Internet Protocol (IP) Security Cameras Systems. (Reserved)**

**7.4.4.2 Digital Video Recording. (Reserved)**

**7.4.4.3 Intrusion Detection Systems. (Reserved)**

**7.4.4.4 Sitewide Monitoring. (Reserved)**

**7.4.4.5 Access Control Systems. (Reserved)**

**7.4.4.6 ID Badging Systems Integrated with Point of Sales Systems. (Reserved)**

**7.4.4.7 Threat Protection Systems. (Reserved)**

**7.4.4.8 Parking Access Systems. (Reserved)**

**7.5 Category 3 Systems.**

**7.5.1 Information Technology and Communications Systems Infrastructure.**

**7.5.1.1** Requirements for information technology and communications systems infrastructure shall be in accordance with 7.3.1, with exceptions as noted in 7.5.1.1.1 through 7.5.1.1.4.

**7.5.1.1.1** Dual service entrance pathways into the EF are not required.

**7.5.1.1.2** Power circuits serving equipment in the EF, the TER, and TRs shall not be required to be connected to the essential electrical system.

**7.5.1.1.3** HVAC systems serving the EF, the ER, and TRs shall not be required to be connected to the essential electrical system.

**7.5.1.1.4** Redundant pathways and cabling for the backbone distribution system shall not be required.

**7.5.2 Voice, Data, Communications, and Cable Television Systems.**

**7.5.2.1 Voice/Telecommunications. (Reserved)**

**7.5.2.2 Local Area Networks (LANS). (Reserved)**

**7.5.2.3 Cable Television. (Reserved)**

**7.5.3 Other Communications Systems.**

**7.5.3.1 Nurse Call Systems. (Reserved)**

**7.5.3.2 Electronic Medical Records and Dictation Systems. (Reserved)**

**7.5.3.3 Medical Imaging Systems. (Reserved)**

**7.5.3.4 Archiving Systems. (Reserved)**

**7.5.4 Security Systems.**

**7.5.4.1 Internet Protocol (IP) Security Cameras Systems. (Reserved)**

**7.5.4.2 Digital Video Recording. (Reserved)**

**7.5.4.3 Intrusion Detection Systems. (Reserved)**

**7.5.4.4 Access Control Systems. (Reserved)**

**Chapter 8 Plumbing**

**Chapter 8 was added by a tentative interim amendment (TIA). See page 1.**

**8.1 Applicability.**

**8.1.1** This chapter shall apply to construction of new health care facilities, except as noted in 8.1.2 and 8.1.3.

**8.1.2** This chapter shall also apply to the altered, renovated, or modernized portions of existing systems or individual components.

**8.1.3** Existing construction or equipment shall be permitted to be continued in use when such use does not constitute a distinct hazard to life.

**8.1.4 Definitions.**

**8.1.4.1 Nonmedical Compressed Air.** Air that is used for purposes other than patient care or medical devices that provide direct patient care.

**8.2\* System Category Criteria.** The health care facility's governing body that has the responsibility for the building system components as identified in this chapter shall designate, in accordance with the function of each space, building system categories in accordance with Sections 4.1 and 4.2.

**8.2.1\*** The category of risk applied to each plumbing system serving a space shall be independent of the category of risk applied to other systems serving that same space.

**8.3 General Requirements.**

**8.3.1 Potable Water.** Potable water systems shall comply with applicable plumbing codes.

**8.3.2 Nonpotable Water.** Nonpotable water systems shall comply with applicable plumbing codes.

**8.3.3\* Water Heating.** Maximum hot water temperatures shall comply with applicable plumbing codes .

**8.3.4 Water Conditioning.** Water shall be treated or heated to control pathogens in the water.

**8.3.5 Nonmedical Compressed Air.**

**8.3.5.1** Nonmedical air compressors shall be listed or approved.

**8.3.5.2** Nonmedical compressed air shall not be used for medical instruments or for human respiration.

**8.3.6 Special Use Water Systems.** When special use water systems are required, application of standards shall be provided in accordance with appropriate publicly reviewed nationally published standards.

**8.3.7 Grease Interceptors.**

**8.3.7.1** Sizing for grease interceptors shall be permitted per local plumbing codes on an engineered calculation factoring meals served per day.

**8.3.7.2** Grease interceptors shall be sized to capture grease from kitchen cooking and cleaning functions and shall prohibit introduction of grease into the sanitary sewer system.

**8.3.8 Fixtures.** Plumbing fixtures shall be suitable for the intended use.

**8.3.9 Black Waste Water.** Black waste water shall be discharged to a sanitary sewer or private on-site waste treatment system as permitted by applicable plumbing codes.

**8.3.10 Gray Waste Water.**

**8.3.10.1** Gray waste water shall be permitted to be stored on-site and used for nonpotable water systems as permitted by applicable plumbing codes.

**8.3.10.2** Gray waste water shall not be used for any system that aerosolizes the water in a breathing zone or has direct contact with humans.

**8.3.10.3** Excess gray waste water shall be discharged to a sanitary sewer or private on-site waste treatment system as permitted by applicable plumbing codes.

**8.3.11 Clear Waste Water.**

**8.3.11.1** Clear waste water shall be permitted to be stored on-site and used for nonpotable water systems as permitted by applicable plumbing codes.

**8.3.11.2** Clear waste water that has been treated to potable water standards shall be permitted to be used as nonpotable water.

**8.3.11.3** Clear waste water that has not been treated to potable water standards shall not be used for any system that aerosolizes the water in a breathing zone or has direct contact with humans.

**8.3.11.4** Excess clear waste water shall be discharged to a storm sewer, held in detention ponds, or recharged into the water table as permitted by applicable plumbing codes.

**Chapter 9 Heating, Ventilation, and Air Conditioning (HVAC)**

**Chapter 9 was added by a tentative interim amendment (TIA). See page 1.**

**9.1 Applicability.**

**9.1.1** This chapter shall apply to construction of new health care facilities, except as noted in 9.1.2 and 9.1.3.

**9.1.2** This chapter shall also apply to the altered, renovated, or modernized portions of existing systems or individual components.

**9.1.3** Existing construction or equipment shall be permitted to be continued in use when such use does not constitute a distinct hazard to life.

**9.1.4 Definitions.**

**9.1.4.1 Ventilation.** The mechanical or natural movement of air.

**9.2\* System Category Criteria.** The health care facility's governing body that has the responsibility for the building system components as identified in this chapter shall designate, in accordance with the function of each space, building system categories in accordance with Sections 4.1 and 4.2.

**9.2.1\*** The category of risk applied to each HVAC system serving a space shall be independent of the category of risk applied to other systems serving that same space.

**9.3 General.**

**9.3.1 Heating, Cooling, Ventilating, and Process Systems.**

**9.3.1.1** Heating, cooling, ventilating, and process systems serving spaces or providing health care functions covered by this code or listed within ASHRAE 170, *Ventilation of Health Care Facilities*, shall be provided in accordance with ASHRAE 170.

**9.3.1.2** Laboratories shall comply with NFPA 45, *Standard on Fire Protection for Laboratories Using Chemicals*.

**9.3.2 Energy Conservation.** Heating, cooling, and ventilating systems serving spaces or providing health care functions covered by this code shall comply with ASHRAE 90.1, *Energy Standard for Buildings Except Low-Rise Residential Buildings*, or another locally adopted energy code.

**9.3.3 Commissioning.**

**9.3.3.1** Heating, cooling, ventilating, and process systems serving spaces or providing health care functions covered by this code shall be commissioned in accordance with ASHRAE 90.1, *Energy Standard for Buildings Except Low-Rise Residential Buildings*.

**9.3.3.2** Commissioning shall follow ASHRAE Guideline 0, *The Commissioning Process*, and ASHRAE Guideline 1.1, *HVAC&R Technical Requirements for the Commissioning Process*, or any other publically reviewed document acceptable to the authority having jurisdiction.

**9.3.4 Piping.** Heating, cooling, ventilating, and process systems serving spaces or providing health care functions covered by this code shall utilize piping systems complying with applicable plumbing codes.

**9.3.5 Ductwork.** Heating, cooling, ventilating, and process systems serving spaces or providing health care functions covered by this code shall utilize ductwork systems complying with NFPA 90A, *Standard for the Installation of Air-Conditioning and Ventilation Systems*, or applicable mechanical codes.

**9.3.6\* Acoustics.** Heating, cooling, ventilating, and process systems serving spaces or providing health care functions covered by this code shall not exceed approved noise criteria.

**9.3.7 Medical Gas Storage or Transfilling.**

**9.3.7.1** All gases, other than medical gases, shall be provided with ventilation per NFPA 55, *Compressed Gases and Cryogenic Fluids Code*.

**9.3.7.2** Outdoor storage/installations for medical gases and cryogenic fluids shall be provided with ventilation per NFPA 55, *Compressed Gases and Cryogenic Fluids Code*.

**9.3.7.3\*** Medical gases and cryogenic fluids that are in use per Chapter 11 shall not require special ventilation.

**9.3.7.4** Transfilling area shall be provided with ventilation in accordance with NFPA 55, *Compressed Gases and Cryogenic Fluids Code*.

**9.3.7.5** Indoor storage or manifold areas and storage or manifold buildings for medical gases and cryogenic fluids shall be provided with natural ventilation or mechanical exhaust ventilation in accordance with 9.3.7.5.1 through 9.3.7.8.

**9.3.7.5.1\*** For the purposes of this section, the volume of fluid (gas and liquid) to be used in determining the ventilation requirements shall be the volume of the stored fluid when expanded to standard temperature and pressure (STP) of either the largest single vessel in the enclosed space or of the entire volume of the connected vessels that are on a common manifold in the enclosed space, whichever is larger.

**9.3.7.5.2 Natural Ventilation.**

**9.3.7.5.2.1** Natural ventilation shall consist of two nonclosable louvered openings, each having an aggregate free opening area of at least 155 cm<sup>2</sup>/35 L (24 in.<sup>2</sup>/1000 ft<sup>3</sup>) of the fluid designed to be stored in the space and in no case less than 465 cm<sup>2</sup> (72 in.<sup>2</sup>).

**9.3.7.5.2.2** One opening shall be located within 30 cm (1 ft) of the floor, and one shall be located within 30 cm (1 ft) of the ceiling.

**9.3.7.5.2.3** The openings shall be located to ensure cross ventilation.

**9.3.7.5.2.4** Natural ventilation openings shall be directly to the outside atmosphere without ductwork.

**9.3.7.5.2.5** Mechanical ventilation shall be provided if natural ventilation requirements cannot be met.

**9.3.7.5.3 Mechanical Ventilation.**

**9.3.7.5.3.1** Mechanical exhaust to maintain a negative pressure in the space shall be provided continuously, unless an alternative design is approved by the authority having jurisdiction.

**9.3.7.5.3.2** Mechanical exhaust shall be at a rate of 1 L/sec of airflow for each 300 L (1 cfm per 5 ft<sup>3</sup> of fluid) designed to be stored in the space and not less than 24 L/sec (50 cfm) nor more than 235 L/sec (500 cfm).

**9.3.7.5.3.3** Mechanical exhaust inlets shall be unobstructed and shall draw air from within 300 mm (1 ft) of the floor and adjacent to the cylinder or containers.

**9.3.7.5.3.4** Mechanical exhaust air fans shall be supplied with electrical power from the essential electrical system.

**9.3.7.5.3.5** Dedicated exhaust systems shall not be required, provided that the system does not connect to spaces that contain combustible or flammable materials.

**9.3.7.5.3.6** The exhaust duct material shall be noncombustible.

**9.3.7.5.3.7** A means of make-up air shall be provided according to one of the following:

- (1) Air shall be permitted via noncombustible ductwork to be transferred from adjacent spaces, from outside the building, or from spaces that do not contain combustible or flammable materials via noncombustible ductwork
- (2) Air shall be permitted to be transferred from a corridor under the door up to the greater of 24 L/sec (50 cfm) or 15 percent of the room exhaust in accordance with NFPA 90A, *Standard for the Installation of Air-Conditioning and Ventilating Systems*.
- (3) Supply air shall be permitted to be provided from any building ventilation system that does not contain flammable or combustible vapors.

**9.3.7.6** Discharge from the natural and mechanical ventilation systems shall be sited by a minimum separation distance in accordance with NFPA 55, *Compressed Gases and Cryogenic Fluids Code*.

**9.3.7.7** A storage room shall maintain a temperature not greater than 52°C (125°F).

**9.3.7.8** A transfer or manifold room shall maintain a temperature not greater than 52°C (125°F) and not less than -7°C (20°F).

**9.3.8 Waste Gas.**

**9.3.8.1** Removal of excess anesthetic gases from the anesthesia circuit shall be accomplished by waste anesthetic gas disposal (WAGD), as described in Chapter 5, or by an active or passive scavenging ventilation system.

**9.3.8.1.1 Active Systems.** A dedicated exhaust system with an exhaust fan shall be provided to interconnect all of the anesthesia gas circuits to provide sufficient airflow and negative pressure in the gas disposal tubing so that cross contamination does not occur in the other circuits connected to the system.

**9.3.8.1.2 Passive Systems.**

**9.3.8.1.2.1** A dedicated exhaust system with an exhaust fan shall be provided to exhaust snorkels at all of the anesthesia gas circuits to provide sufficient airflow to capture the gases, vapors, and particles expelled from the gas disposal tubing.

**9.3.8.1.2.2** The snorkel shall include a minimum 25.4 mm (1 in.) diameter tubing connected to the exhaust system.

**9.3.8.2** All the exhausted air shall be vented to the external atmosphere.

**9.3.8.3** The excess anesthetic gases shall be deposited into the exhaust stream either at the exhaust grille or further downstream in the exhaust duct.

**9.3.9 Medical Plume Evacuation.** Plumes from medical procedures, including the use of lasers, shall be captured by one of the following methods:

- (1) Direct connection to an unfiltered dedicated exhaust system that discharges outside the building
- (2) HEPA filtering and direct connection to a return or exhaust duct
- (3) Chemical and thermal sterilization and return to the space.



### 9.3.10 Emergency Power System Room.

**9.3.10.1** Heating, cooling, and ventilating of the emergency power system shall be in accordance with NFPA 110, *Standard for Emergency and Standby Power Systems*.

**9.3.10.2 Maintenance of Temperature.** The EPS shall be heated as necessary to maintain the water jacket and battery temperature determined by the EPS manufacturer for cold start and load acceptance for the type of EPSS. [110:5.3.1]

#### 9.3.10.3 Heating, Cooling, and Ventilating.

**9.3.10.3.1\*** With the EPS running at rated load, ventilation air flow shall be provided to limit the maximum air temperature in the EPS room to the maximum ambient air temperature required by the EPS manufacturer. [110:7.7.1]

**9.3.10.3.1.1** Consideration shall be given to all the heat emitted to the EPS equipment room by the energy converter, uninsulated or insulated exhaust pipes, and other heat-producing equipment. [110:7.7.1.1]

**9.3.10.3.2** Air shall be supplied to the EPS equipment for combustion. [110:7.7.2]

**9.3.10.3.2.1** For EPS supplying Level 1 EPSS, ventilation air shall be supplied directly from a source outside of the building by an exterior wall opening or from a source outside the building by a 2-hour fire-rated air transfer system. [110:7.7.2.1]

**9.3.10.3.2.2** For EPS supplying Level 1 EPSS, discharge air shall be directed outside of the building by an exterior wall opening or to an exterior opening by a 2-hour fire-rated air transfer system. [110:7.7.2.2]

**9.3.10.3.2.3** Fire dampers, shutters, or other self-closing devices shall not be permitted in ventilation openings or ductwork for supply or return/discharge air to EPS equipment for Level 1 EPSS. [110:7.7.2.3]

**9.3.10.3.3** Ventilation air supply shall be from outdoors or from a source outside of the building by an exterior wall opening or from a source outside the building by a 2-hour fire-rated air transfer system. [110:7.7.3]

**9.3.10.3.4** Ventilation air shall be provided to supply and discharge cooling air for radiator cooling of the EPS when running at rated load. [110:7.7.4]

**9.3.10.3.4.1** Ventilation air supply and discharge for radiator-cooled EPS shall have a maximum static restriction of 125 Pa (0.5 in. of water column) in the discharge duct at the radiator outlet. [110:7.7.4.1]

**9.3.10.3.4.2** Radiator air discharge shall be ducted outdoors or to an exterior opening by a 2-hour rated air transfer system. [110:7.7.4.2]

**9.3.10.3.5** Motor-operated dampers, when used, shall be spring operated to open and motor closed. Fire dampers, shutters, or other self-closing devices shall not be permitted in ventilation openings or ductwork for supply or return/discharge air to EPS equipment for Level 1 EPSS. [110:7.7.5]

**9.3.10.3.6** The ambient air temperature in the EPS equipment room or outdoor housing containing Level 1 rotating equipment shall be not less than 4.5°C (40°F). [110:7.7.6]

**9.3.10.3.7** Units housed outdoors shall be heated as specified in 5.3.1 [of NFPA 110, *Standard for Emergency and Standby Power Systems*]. [110:7.7.7]

**9.3.10.3.8** Design of the heating, cooling, and ventilation system for the EPS equipment room shall include provision for factors including, but not limited to, the following:

- (1) Heat
- (2) Cold
- (3) Dust
- (4) Humidity
- (5) Snow and ice accumulations around housings
- (6) Louvers
- (7) Remote radiator fans
- (8) Prevailing winds blowing against radiator fan discharge air [110:7.7.8]

**9.3.11\* Ventilation During Construction.** Ventilation during construction shall comply with the applicable mechanical codes.

## Chapter 10 Electrical Equipment

### 10.1\* Applicability.

**10.1.1** This chapter shall apply to the performance, maintenance, and testing of electrical equipment in health care facilities, as specified in Section 1.3.

**10.1.2** Experimental or research apparatus built to order or under development shall be used under qualified supervision and shall have a degree of safety that is equivalent to that described herein or that has been deemed acceptable by the facility.

### 10.2 Performance Criteria and Testing for Patient Care-Related Electrical Appliances and Equipment.

**10.2.1 Permanently Connected — Fixed Equipment.** Patient-connected electric appliances shall be grounded to the equipment grounding bus in the distribution panel by an insulated grounding conductor run with the power conductors.

#### 10.2.2 Cord- and Plug-Connected — Portable Equipment.

##### 10.2.2.1 Grounding of Appliances.

**10.2.2.1.1** All cord-connected electrically powered appliances that are not double insulated and are used in the patient care vicinity shall be provided with a three-wire power cord and a three-pin grounding-type plug.

**10.2.2.1.2** Double-insulated appliances shall be permitted to have two conductor cords and shall be rated as Class II devices.

**10.2.2.2 Attachment Plugs.** Attachment plugs listed for the purpose shall be used on all cord-connected appliances.

**10.2.2.3 Construction and Use.** The attachment plug shall be a two-pole, three-wire grounding type.

**10.2.2.3.1** Appliances supplied by other than 120-V single-phase systems shall use the grounding-type plug (cap) appropriate for the particular power system.

**10.2.2.3.2** The grounding prong of the plug shall be the first to be connected to, and the last to be disconnected from, the receptacle.

**10.2.2.3.3** If screw terminals are used, the stranded conductor shall be twisted to prevent stray strands, but the bundle shall not be tinned after twisting.

**10.2.2.3.4** If the conductor is not twisted, it shall be attached by an approved terminal lug.

**10.2.2.3.5** The power cord conductors shall be arranged so that the conductors are not under tension in the plug.

**10.2.2.3.6** The grounding conductor shall be the last one to disconnect when a failure of the plug's strain relief allows the energized conductors to be disrupted.

**10.2.2.3.7 Strain Relief.** Strain relief shall be provided.

**10.2.2.3.7.1** The strain relief shall not cause thinning of the conductor insulation.

**10.2.2.3.7.2** The strain relief of replaceable plugs shall be capable of being disassembled.

**10.2.2.3.7.3** Plugs shall be permitted to be integrally molded onto the cord jacket if the design is listed for the purpose.

**10.2.2.3.8 Testing.** The wiring of each cord assembly shall be tested for continuity and polarity at the time of manufacture, when assembled into an appliance, and when repaired.

### **10.2.3 Power Cords.**

#### **10.2.3.1 Material and Gauge.**

**10.2.3.1.1** The flexible cord, including the grounding conductor, shall be of a type suitable for the particular application; shall be listed for use at a voltage equal to or greater than the rated power line voltage of the appliance; and shall have an ampacity, as given in Table 400.5(A) of *NFPA 70, National Electrical Code*, equal to or greater than the current rating of the device.

**10.2.3.1.2** "Hard Service" (SO, ST, or STO), "Junior Hard Service" (SJO, SJT, or SJTO), or equivalent listed flexible cord shall be used, except where an appliance with a cord of another designation has been listed for the purpose.

#### **10.2.3.2 Grounding Conductor.**

**10.2.3.2.1** Each electric appliance shall be provided with a grounding conductor in its power cord.

**10.2.3.2.2** The grounding conductor shall be not smaller than 18 AWG.

**10.2.3.2.3** The grounding conductor of cords longer than 4.6 m (15 ft) shall be not smaller than 16 AWG.

**10.2.3.2.4\*** A grounding conductor in the power cord shall not be required for double-insulated appliances, but a functional ground conductor (functional earth conductor) shall be permitted.

#### **10.2.3.3 Separable Cord Sets.**

**10.2.3.3.1** A detachable power cord shall be permitted if an accidental disconnection would not present an unacceptable hazard or if a mechanism that reliably prevents inadvertent disconnection is used.

**10.2.3.3.2** Separable power cord sets shall be designed so that the grounding conductor is the first to be connected and the last to be disconnected.

**10.2.3.3.3** The cord set to the appliance shall be listed for the purpose.

#### **10.2.3.4 Connection to Circuit and Color Codes.**

**10.2.3.4.1** Power cords, regardless of whether intended for use on grounded or isolated power systems, shall be connected in accordance with the conventions of a grounded system.

**10.2.3.4.2** The circuit conductors in the cord shall be connected to the plug and the wiring in the appliance so that any of the following devices, when used in the primary circuit, are connected to the ungrounded conductor:

- (1) Center contact of an Edison base lampholder
- (2) Solitary fuseholder
- (3) Single-pole, overcurrent protective device
- (4) Any other single-pole, current-interrupting device

**10.2.3.4.3** A second fuseholder or other overcurrent protective device provided in the appliance shall be permitted to be placed in the grounded side of the line.

#### **10.2.3.5 Cord Strain Relief.**

**10.2.3.5.1** Cord strain relief shall be provided at the attachment of the power cord to the appliance so that mechanical stress, either pull, twist, or bend, is not transmitted to internal connections.

**10.2.3.5.2** A strain relief molded onto the cord shall be bonded to the jacket and shall be of compatible material.

**10.2.3.6 Multiple Outlet Connection.** Two or more power receptacles supplied by a flexible cord shall be permitted to be used to supply power to plug-connected components of a movable equipment assembly that is rack-, table-, pedestal-, or cart-mounted, provided that all of the following conditions are met:

- (1) The receptacles are permanently attached to the equipment assembly.
- (2)\*The sum of the ampacity of all appliances connected to the outlets does not exceed 75 percent of the ampacity of the flexible cord supplying the outlets.
- (3) The ampacity of the flexible cord is in accordance with *NFPA 70, National Electrical Code*.
- (4)\*The electrical and mechanical integrity of the assembly is regularly verified and documented.
- (5)\*Means are employed to ensure that additional devices or nonmedical equipment cannot be connected to the multiple outlet extension cord after leakage currents have been verified as safe.

#### **10.2.4 Adapters and Extension Cords.**

**10.2.4.1** Three-prong to two-prong adapters shall not be permitted.

**10.2.4.2** Adapters and extension cords meeting the requirements of 10.2.4.2.1 through 10.2.4.2.3 shall be permitted.

**10.2.4.2.1** All adapters shall be listed for the purpose.

**10.2.4.2.2** Attachment plugs and fittings shall be listed for the purpose.

**10.2.4.2.3** The cabling shall comply with 10.2.3.

### **10.3 Testing Requirements — Fixed and Portable.**

**10.3.1\* Physical Integrity.** The physical integrity of the power cord assembly composed of the power cord, attachment plug, and cord-strain relief shall be confirmed by visual inspection.

#### **10.3.2\* Resistance.**

**10.3.2.1** For appliances that are used in the patient care vicinity, the resistance between the appliance chassis, or any exposed conductive surface of the appliance, and the ground pin of the attachment plug shall be less than 0.50 ohm under the following conditions:

- (1) The cord shall be flexed at its connection to the attachment plug or connector.
- (2) The cord shall be flexed at its connection to the strain relief on the chassis.

**10.3.2.2** The requirement of 10.3.2.1 shall not apply to accessible metal parts that achieve separation from main parts by double insulation or metallic screening or that are unlikely to become energized (e.g., escutcheons or nameplates, small screws).

#### **10.3.3\* Leakage Current Tests.**

##### **10.3.3.1 General.**

**10.3.3.1.1** The requirements in 10.3.3.2 through 10.3.3.4 shall apply to all tests.

**10.3.3.1.2** Tests shall be performed with the power switch ON and OFF.

**10.3.3.2 Resistance Test.** The resistance tests of 10.3.3.3 shall be conducted before undertaking any leakage current measurements.

**10.3.3.3\* Techniques of Measurement.** The test shall not be made on the load side of an isolated power system or separable isolation transformer.

**10.3.3.4\* Leakage Current Limits.** The leakage current limits in 10.3.4 and 10.3.5 shall be followed.

**10.3.4 Leakage Current — Fixed Equipment.**

**10.3.4.1** Permanently wired appliances in the patient care vicinity shall be tested prior to installation while the equipment is temporarily insulated from ground.

**10.3.4.2** The leakage current flowing through the ground conductor of the power supply connection to ground of permanently wired appliances installed in general or critical care areas shall not exceed 10.0 mA (ac or dc) with all grounds lifted.

**10.3.5 Touch Current — Portable Equipment.**

**10.3.5.1\* Touch Current Limits.** The touch current for cord-connected equipment shall not exceed 100  $\mu$ A with the ground wire intact (if a ground wire is provided) with normal polarity and shall not exceed 500  $\mu$ A with the ground wire disconnected.

**10.3.5.2** If multiple devices are connected together and one power cord supplies power, the leakage current shall be measured as an assembly.

**10.3.5.3** When multiple devices are connected together and more than one power cord supplies power, the devices shall be separated into groups according to their power supply cord, and the leakage current shall be measured independently for each group as an assembly.

**10.3.5.4 Touch Leakage Test Procedure.** Measurements shall be made using the circuit, as illustrated in Figure 10.3.5.4, with the appliance ground broken in two modes of appliance operation as follows:

- (1) Power plug connected normally with the appliance on
- (2) Power plug connected normally with the appliance off (if equipped with an on/off switch)

**10.3.5.4.1** If the appliance has fixed redundant grounding (e.g., permanently fastened to the grounding system), the touch leakage current test shall be conducted with the redundant grounding intact.

**10.3.5.4.2** Test shall be made with Switch A in Figure 10.3.5.4 closed.

**10.3.6\* Lead Leakage Current Tests and Limits — Portable Equipment.**

**10.3.6.1** The leakage current between all patient leads connected together and ground shall be measured with the power plug connected normally and the device on.

**10.3.6.2** An acceptable test configuration shall be as illustrated in Figure 10.3.5.4.

**10.3.6.3** The leakage current shall not exceed 100  $\mu$ A for ground wire closed and 500  $\mu$ A ac for ground wire open.

**10.4 Nonpatient Electrical Appliances and Equipment.**

**10.4.1 Permanently Connected — Fixed. (Reserved)**

**10.4.2 Cord- and Plug-Connected — Portable Equipment in Patient Care Room.**

**10.4.2.1** Nonpatient care-related electrical equipment, including facility- or patient-owned appliances that are used in the patient care vicinity and will, in normal use, contact patients, shall be visually inspected by the patient's care staff or other personnel.

**10.4.2.2** Any equipment that appears not to be in proper working order or in a worn condition shall be removed from service or reported to the appropriate maintenance staff.

**10.4.2.3** Household or office appliances not commonly equipped with grounding conductors in their power cords shall be permitted, provided that they are not located within the patient care vicinity. Double-insulated appliances shall be permitted in the patient care vicinity.

**10.5 Administration.**

**10.5.1 Responsibilities of Governing Body. (Reserved)**

**10.5.2 Policies.**

**10.5.2.1 Testing Intervals.**

**10.5.2.1.1** The facility shall establish policies and protocols for the type of test and intervals of testing for patient care-related electrical equipment.

**10.5.2.1.2** All patient care-related electrical equipment used in patient care rooms shall be tested in accordance with 10.3.5.4 or 10.3.6 before being put into service for the first time and after any repair or modification that might have compromised electrical safety.

**10.5.2.2 Protection of Patients with Direct Electrical Pathways to the Heart.** Only equipment that is specifically designed for the purpose [i.e., provided with suitable isolated patient leads or connections (cardiac floating, also known as CF, according to IEC 60601-1-2, *Medical Electrical Equipment — Part 1-2: General Requirements for Safety — Collateral Standard: Electromagnetic Compatibility — Requirements and Tests*)] shall be connected directly to electrically conductive pathways to a patient's heart.

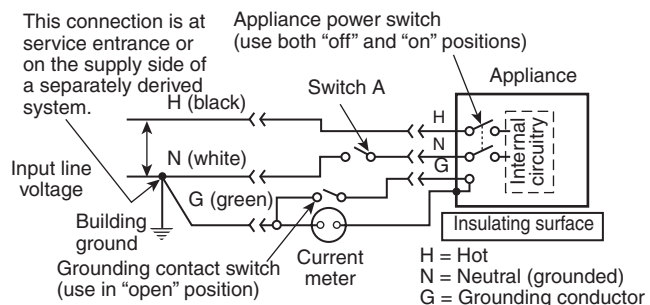
**10.5.2.3 Adapters and Extension Cords.**

**10.5.2.3.1** Adapters and extension cords meeting the requirements of 10.2.4 shall be permitted to be used.

**10.5.2.3.2** Three-to-two-prong adapters shall not be permitted.

**10.5.2.3.3** The wiring shall be tested for all of the following:

- (1) Physical integrity
- (2) Polarity
- (3) Continuity of grounding at the time of assembly and periodically thereafter



**FIGURE 10.3.5.4 Test Circuit for Measuring Touch Leakage Current.**

**10.5.2.4 Devices Likely to Be Used During Defibrillation.** Devices that are critical to patient safety and that are likely to be attached to the patient when a defibrillator is used (such as ECG monitors) shall be rated as “defibrillator proof.”

**10.5.2.5\* System Demonstration.** Any system consisting of several electric appliances shall be demonstrated to comply with this code as a complete system.

**10.5.2.6 Electrical Equipment Systems.** Purchase contracts for electrical equipment systems, such as nurse call and signaling that consist of interconnected elements, shall require all of the following:

- (1) The elements are intended to function together.
- (2) The manufacturers provide documentation for such interconnection.
- (3) The systems are installed by personnel qualified to do such installations.

**10.5.2.7 Appliances Not Provided by the Facility.** Policies shall be established for the control of appliances not supplied by the facility.

**10.5.3 Servicing and Maintenance of Equipment.**

**10.5.3.1** The manufacturer of the appliance shall furnish documents containing at least a technical description, instructions for use, and a means of contacting the manufacturer.

**10.5.3.1.1** The documents specified in 10.5.3.1 shall include the following, where applicable:

- (1) Illustrations that show the location of controls
- (2) Explanation of the function of each control
- (3) Illustrations of proper connection to the patient or other equipment, or both
- (4) Step-by-step procedures for testing and proper use of the appliance
- (5) Safety considerations in use and servicing of the appliance
- (6) Precautions to be taken if the appliance is used on a patient simultaneously with other electric appliances
- (7) Schematics, wiring diagrams, mechanical layouts, parts lists, and other pertinent data for the appliance
- (8) Instructions for cleaning, disinfection, or sterilization
- (9) Utility supply requirements (electrical, gas, ventilation, heating, cooling, and so forth)
- (10) Explanation of figures, symbols, and abbreviations on the appliance
- (11) Technical performance specifications
- (12) Instructions for unpacking, inspection, installation, adjustment, and alignment
- (13) Preventive and corrective maintenance and repair procedures

**10.5.3.1.2** Service manuals, instructions, and procedures provided by the manufacturer shall be considered in the development of a program for maintenance of equipment.

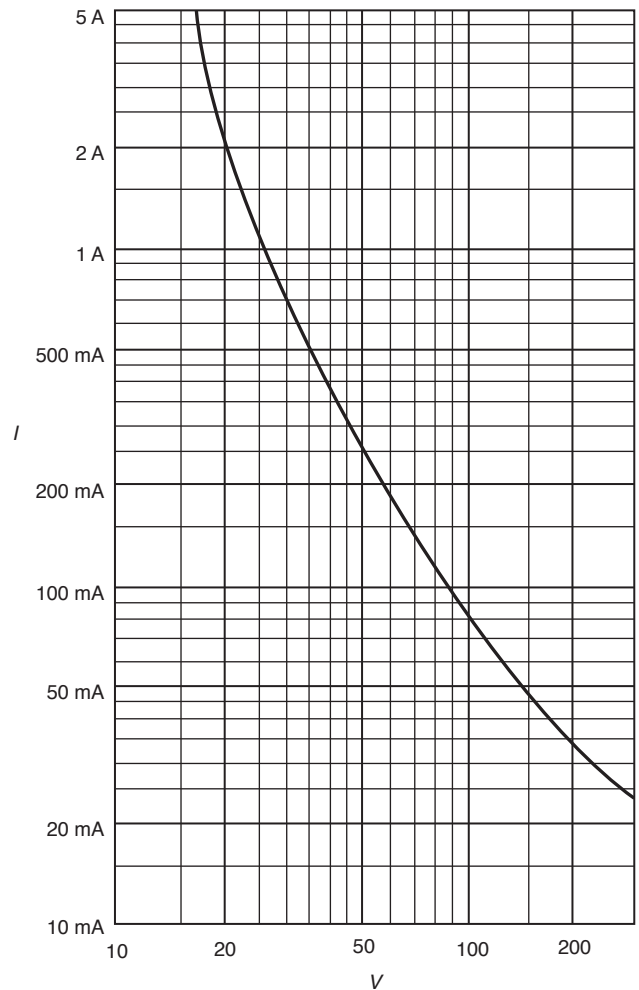
**10.5.4 Administration of Oxygen Therapy.**

**10.5.4.1 Electrical Equipment in Oxygen-Enriched Atmospheres.** Appliances, or a part(s) of an appliance or a system (e.g., pillow speaker, remote control, pulse oximeter probe), to be used in the site of intentional expulsion shall comply with one of the following:

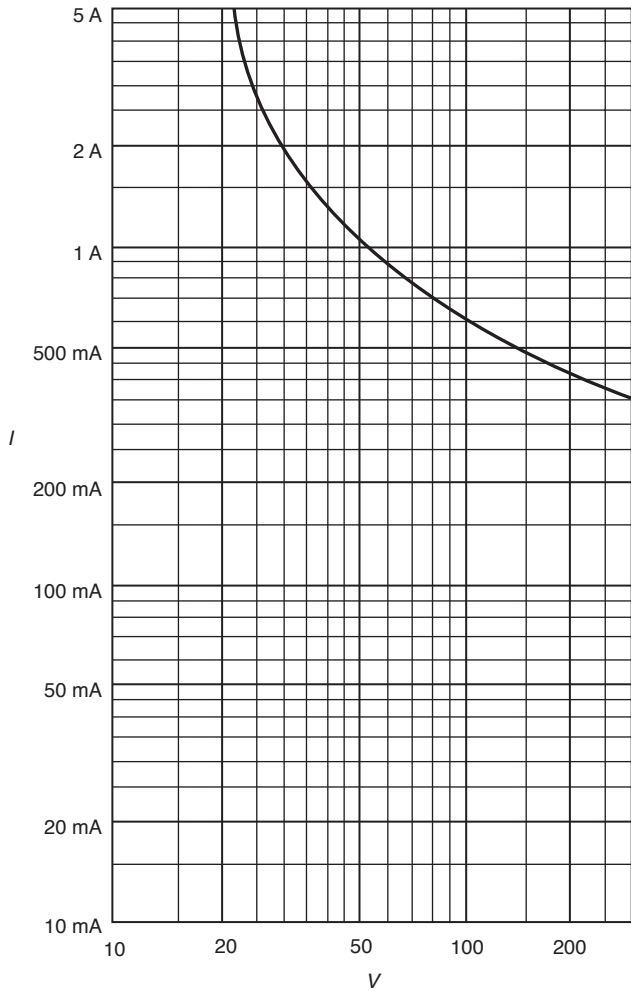
- (1) They shall be listed for use in oxygen-enriched atmospheres.
- (2) They shall be sealed so as to prevent an oxygen-enriched atmosphere from reaching electrical components, with sealing material of the type that will still seal even after

- repeated exposure to water, oxygen, mechanical vibration, and heating from the external circuitry.
- (3) They shall be ventilated so as to limit the oxygen concentration surrounding electrical components to below 23.5 percent by volume.
- (4) They shall have both of the following characteristics:
  - (a) No hot surfaces over 300°C (573°F), except for small (less than 2 W) hermetically sealed heating elements, such as light bulbs
  - (b) No exposed switching or sparking points of electrical energy that fall to the right of the curve for the appropriate type of circuit illustrated in Figure 10.5.4.1(a) through Figure 10.5.4.1(f), with the dc (or peak ac) open-circuit voltage and short-circuit current required to be used

**10.5.4.2** When only the remote control or signal leads of a device are to be used in the site of intentional expulsion, only the control or signal leads shall be required to comply with 10.5.4.1.



**FIGURE 10.5.4.1(a) Resistance Circuits (L < 1 mH): Minimum Igniting Currents, Applicable to All Circuits Containing Cadmium, Zinc, or Magnesium.**



**FIGURE 10.5.4.1(b) Resistance Circuits ( $L < 1$  mH): Minimum Igniting Currents, Applicable to Circuits Where Cadmium, Zinc, or Magnesium Can Be Excluded.**

**10.5.4.3** Subparagraphs 10.5.4.1 and 10.5.4.2 shall not apply to small (less than 2 W), hermetically sealed heating elements such as light bulbs.

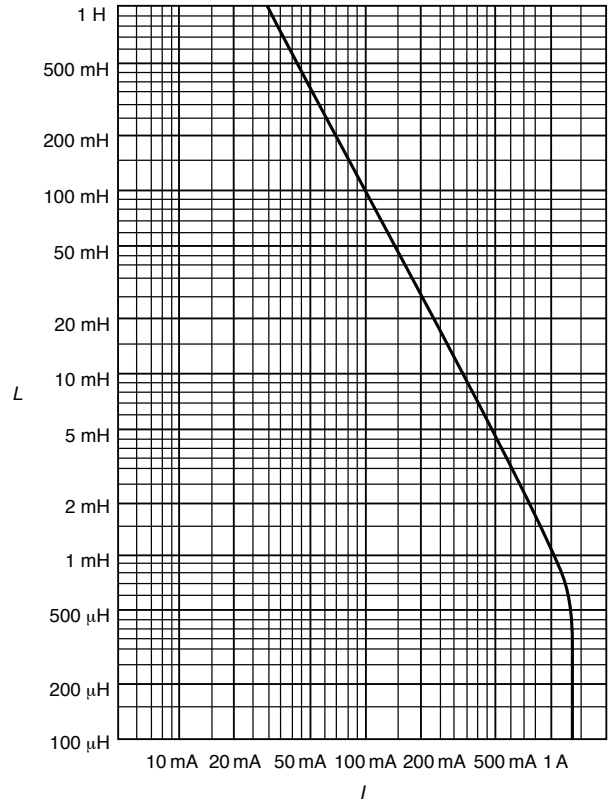
**10.5.4.4** Electrical equipment sold with the intent to be used in oxygen-enriched atmospheres shall be listed for use in oxygen-enriched atmospheres.

**10.5.4.5\*** Electrical equipment used within oxygen delivery equipment shall be listed for use in oxygen-enriched atmospheres in accordance with ANSI/AAMI ES 60601-1, *Medical Electrical Equipment*.

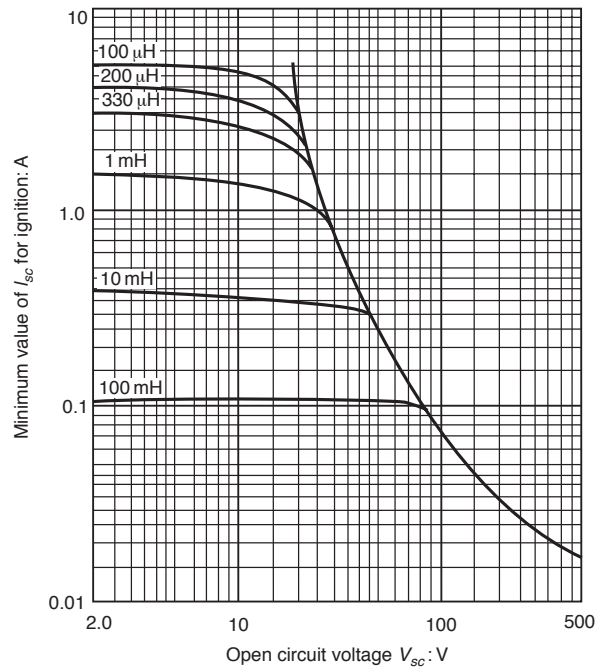
**10.5.4.6\*** High-energy-delivering probes (such as defibrillator paddles) or other electrical devices that do not comply with 10.5.4.1 and 10.5.4.2, that are deemed essential to the care of an individual patient, and that must be used within an administration site or within oxygen-delivery equipment shall be permitted.

**10.5.5 Laboratory.**

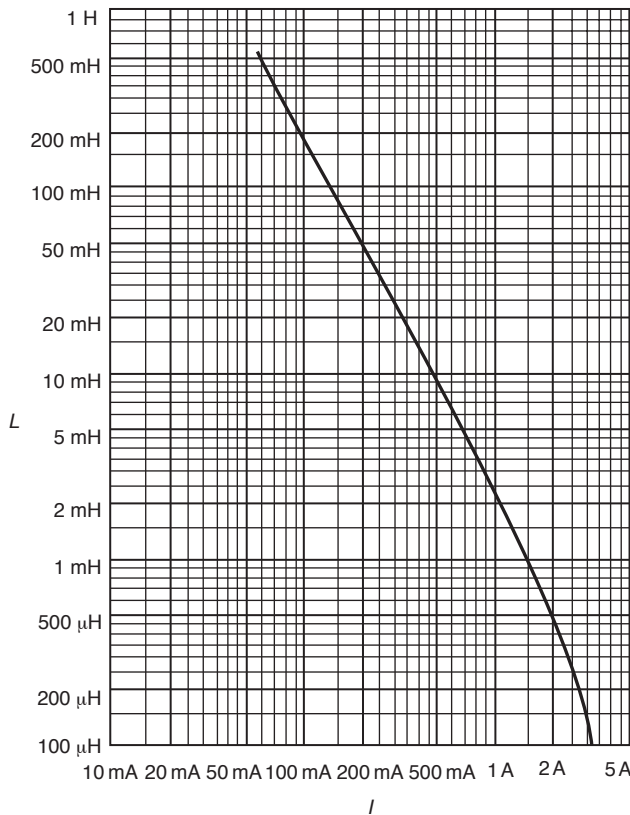
**10.5.5.1\*** The laboratory shall establish policies and protocols for the type of test and intervals of testing for appliances.



**FIGURE 10.5.4.1(c) Inductance Circuits ( $L > 1$  mH): Minimum Igniting Currents at 24 V, Applicable to All Circuits Containing Cadmium, Zinc, or Magnesium.**



**FIGURE 10.5.4.1(d) Inductance Circuits ( $L > 1$  mH): Minimum Igniting Currents for Various Voltages, Applicable to All Circuits Containing Cadmium, Zinc, or Magnesium.**



**FIGURE 10.5.4.1(e) Inductance Circuits ( $L > 1$  mH): Minimum Igniting Currents at 24 V, Applicable Only to Circuits Where Cadmium, Zinc, or Magnesium Can Be Excluded.**

**10.5.5.2\*** The physical integrity of the power cord, attachment plug, and cord-strain relief shall be confirmed at least annually by visual inspection and other appropriate tests.

**10.5.6 Record Keeping — Patient Care Appliances.**

**10.5.6.1 Instruction Manuals.**

**10.5.6.1.1** A permanent file of instruction and maintenance manuals shall be maintained and be accessible.

**10.5.6.1.2** The file of manuals shall be in the custody of the engineering group responsible for the maintenance of the appliance.

**10.5.6.1.3** Duplicate instruction and maintenance manuals shall be available to the user.

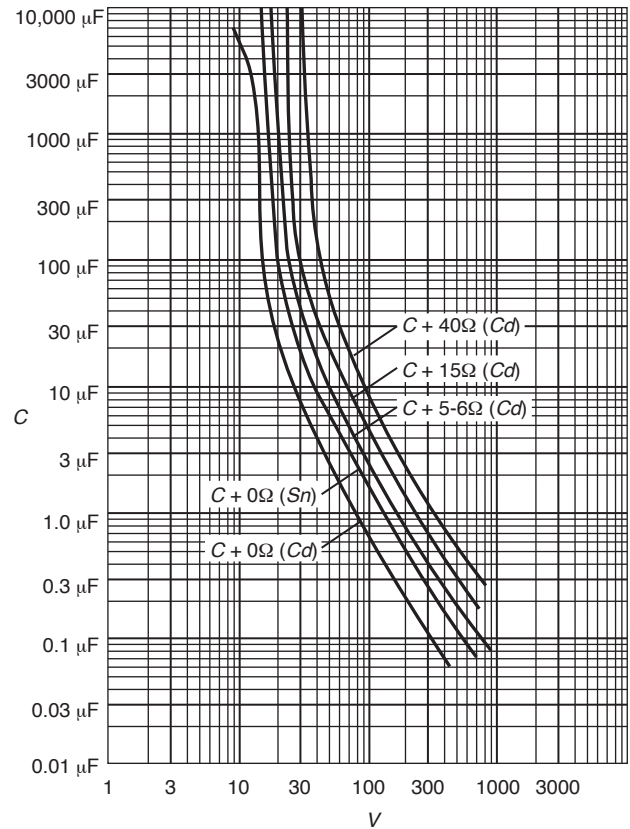
**10.5.6.1.4** Any safety labels and condensed operating instructions on an appliance shall be maintained in legible condition.

**10.5.6.2\* Documentation.**

**10.5.6.2.1** A record shall be maintained of the tests required by this chapter and associated repairs or modifications.

**10.5.6.2.2** At a minimum, the record shall contain all of the following:

- (1) Date
- (2) Unique identification of the equipment tested
- (3) Indication of which items have met or have failed to meet the performance requirements of 10.5.6.2



**FIGURE 10.5.4.1(f) Capacitance Circuits Minimum Ignition Voltages.** (The curves correspond to values of current-limiting resistance as indicated. The curve marked *Sn* is applicable only where cadmium, zinc, or magnesium can be excluded.)

**10.5.6.3 Test Logs.** A log of test results and repairs shall be maintained and kept for a period of time in accordance with a health care facility's record retention policy.

**10.5.7 Use. (Reserved)**

**10.5.8 Qualification and Training of Personnel.**

**10.5.8.1\*** Personnel concerned for the application or maintenance of electric appliances shall be trained on the risks associated with their use.

**10.5.8.1.1** The health care facilities shall provide programs of continuing education for its personnel.

**10.5.8.1.2** Continuing education programs shall include periodic review of manufacturers' safety guidelines and usage requirements for electrosurgical units and similar appliances.

**10.5.8.2** Personnel involved in the use of energy-delivering devices including, but not limited to, electrosurgical, surgical laser, and fiberoptic devices shall receive periodic training in fire suppression.

**10.5.8.3** Equipment shall be serviced by qualified personnel only.

## Chapter 11 Gas Equipment

### 11.1 Applicability.

**11.1.1\*** This chapter shall apply to the use, at normal atmospheric pressure, of all of the following:

- (1) Nonflammable medical gases
- (2) Vapors and aerosols
- (3) Equipment required for the administration of 11.1.1(1) and (2)

**11.1.2** When used in this chapter, the term *oxygen* shall be intended to mean 100 percent oxygen as well as mixtures of oxygen and air.

**11.1.3\*** This chapter shall not apply to special atmospheres, such as those encountered in hyperbaric chambers.

### 11.2 Cylinder and Container Source.

**11.2.1** Cylinders and containers shall comply with 5.1.3.1.

**11.2.2** Cylinder valve outlet connections shall conform to CGA V-1, *Standard for Compressed Gas Cylinder Valve Outlet and Inlet Connections* (ANSI B57.1) (includes Pin-Index Safety System for medical gases). (See 5.1.3.1.4.)

**11.2.3** When low pressure threaded connections are employed, they shall be in accordance with CGA V-5, *Diameter-Index Safety System (Noninterchangeable Low Pressure Connections for Medical Gas Applications)*, for noninterchangeable, low pressure connections for medical gases, air, and suction.

**11.2.4** Low pressure quick coupler connections shall be non-interchangeable between gas services.

**11.2.5** Pressure reducing regulators and gauges intended for use in high pressure service shall be listed for such service.

**11.2.6** Pressure reducing regulators shall be used on high pressure cylinders to reduce the cylinder pressure to working pressures.

**11.2.7** Approved pressure reducing regulators or other gas-flow control devices shall be used to reduce the cylinder pressure of every cylinder used for medical purposes. All such devices shall have connections so designed that they attach only to cylinders of gas for which they are designated.

**11.2.8\*** Equipment that could allow the intermixing of different gases, either through defects in the mechanism or through error in manipulation in any portion of the high pressure side of any system in which these gases might flow, shall not be used for joining cylinders containing compressed gases.

**11.2.9** Cylinder valve outlet connections for oxygen shall be Connection No. 540 or Connection No. 870 as described in CGA V-1, *Standard for Compressed Gas Cylinder Valve Outlet and Inlet Connections* (ANSI B57.1).

**11.2.10** Cylinder valve outlet connections for nitrous oxide shall be Connection No. 326 or Connection No. 910 as described in CGA V-1, *Standard for Compressed Gas Cylinder Valve Outlet and Inlet Connections* (ANSI B57.1).

### 11.3 Cylinder and Container Storage Requirements.

**11.3.1\*** Storage for nonflammable gases equal to or greater than 85 m<sup>3</sup> (3000 ft<sup>3</sup>) at STP shall comply with 5.1.3.3.2 and 5.1.3.3.3.

**11.3.2\*** Storage for nonflammable gases greater than 8.5 m<sup>3</sup> (300 ft<sup>3</sup>), but less than 85 m<sup>3</sup> (3000 ft<sup>3</sup>), at STP shall comply with the requirements in 11.3.2.1 through 11.3.2.3.

**11.3.2.1** Storage locations shall be outdoors in an enclosure or within an enclosed interior space of noncombustible or limited-combustible construction, with doors (or gates outdoors) that can be secured against unauthorized entry.

**11.3.2.2** Oxidizing gases, such as oxygen and nitrous oxide, shall not be stored with any flammable gas, liquid, or vapor.

**11.3.2.3** Oxidizing gases such as oxygen and nitrous oxide shall be separated from combustibles or materials by one of the following:

- (1) Minimum distance of 6.1 m (20 ft)
- (2) Minimum distance of 1.5 m (5 ft) if the entire storage location is protected by an automatic sprinkler system designed in accordance with NFPA 13, *Standard for the Installation of Sprinkler Systems*
- (3) Enclosed cabinet of noncombustible construction having a minimum fire protection rating of ½ hour

**11.3.2.4** Gas cylinder and cryogenic liquid container storage shall comply with 5.1.3.5.12.

**11.3.2.5** Cylinder and container storage locations shall comply with 5.1.3.3.1.7 with respect to temperature limitations.

**11.3.2.6** Cylinder or container restraints shall comply with 11.6.2.3.

**11.3.2.7** Smoking, open flames, electric heating elements, and other sources of ignition shall be prohibited within storage locations and within 6.1 m (20 ft) of outside storage locations.

**11.3.2.8** Cylinder valve protection caps shall comply with 11.6.2.3.

**11.3.2.9** Gas cylinder and liquefied gas container storage shall comply with 5.1.3.5.12.

**11.3.3** Storage for nonflammable gases with a total volume equal to or less than 8.5 m<sup>3</sup> (300 ft<sup>3</sup>) shall comply with the requirements in 11.3.3.1 and 11.3.3.2.

**11.3.3.1** Individual cylinder storage associated with patient care areas, not to exceed 2100 m<sup>2</sup> (22,500 ft<sup>2</sup>) of floor area, shall not be required to be stored in enclosures.

**11.3.3.2** Precautions in handling cylinders specified in 11.3.3.1 shall be in accordance with 11.6.2.

**11.3.3.3** When small-size (A, B, D, or E) cylinders are in use, they shall be attached to a cylinder stand or to medical equipment designed to receive and hold compressed gas cylinders.

**11.3.3.4** Individual small-size (A, B, D, or E) cylinders available for immediate use in patient care areas shall not be considered to be in storage.

**11.3.3.5** Cylinders shall not be chained to portable or movable apparatus such as beds and oxygen tents.

### 11.3.4 Signs.

**11.3.4.1** A precautionary sign, readable from a distance of 1.5 m (5 ft), shall be displayed on each door or gate of the storage room or enclosure.

**11.3.4.2** The sign shall include the following wording as a minimum:

**CAUTION:**  
**OXIDIZING GAS(ES) STORED WITHIN**  
**NO SMOKING**

#### **11.4 Performance Criteria and Testing.**

##### **11.4.1 Portable Patient Care Gas Equipment.**

**11.4.1.1\*** Anesthetic apparatus shall be subject to approval by the authority having jurisdiction.

**11.4.1.2\*** Each yoke on anesthetic apparatus constructed to allow attachment of a small cylinder equipped with a flush-type valve shall have two pins installed as specified in CGA V-1, *Standard for Compressed Gas Cylinder Valve Outlet and Inlet Connections* (ANSI B57.1).

##### **11.4.1.3 Testing.**

**11.4.1.3.1** Interventions requiring testing shall include, but not be limited to, the following:

- (1) Alteration of pipeline hose or pipeline fittings
- (2) Alteration of internal piping
- (3) Adjustment of selector switches or flush valves
- (4) Replacement or repair of flowmeters or bobbins

**11.4.1.3.2** After any adjustment or repair involving use of tools, or any modification of the gas piping supply connections or the pneumatic power supply connections for the anesthesia ventilator, or other pneumatically powered device, if one is present, and before use on patients, the gas anesthesia apparatus shall be tested at the final common path to the patient to determine that oxygen, and only oxygen, is delivered from the oxygen flowmeters and the oxygen flush valve, if any.

**11.4.1.3.3** Before the gas anesthesia apparatus is returned to service, each fitting and connection shall be checked to verify its proper indexing to the respective gas service involved.

**11.4.1.3.4** Before the gas anesthesia apparatus is returned to service, an oxygen analyzer, or a similar device, shall be used to verify the oxygen concentration.

**11.4.1.4\*** Yoke-type connections between anesthesia apparatus and flush-type cylinder valves (commonly used with anesthetic gas cylinders) shall be of the Connection No. 860 type in accordance with CGA V-1, *Compressed Gas Cylinder Valve Outlet and Inlet Connections* (ANSI B57.1).

##### **11.4.2 Apparatus for Administering Respiratory Therapy.**

**11.4.2.1** Oxygen-delivery equipment intended to rest on the floor shall be equipped with a base designed to render the entire assembly stable during storage, transport, and use. If casters are used, they shall conform to Class C of U.S. Government Commercial Standard 223-59, *Casters, Wheels, and Glides for Hospital Equipment*.

**11.4.2.2** Oxygen enclosures of rigid materials shall be fabricated of noncombustible materials.

**11.4.2.3** Equipment supplied from cylinders or containers shall be designed and constructed for service at full cylinder or container pressure or constructed for use with, or equipped with, pressure reducing regulators.

**11.4.2.4** Humidification or reservoir jars containing liquid to be dispersed into a gas stream shall be made of transparent or

translucent material, shall be impervious to contained solutions and medications, and shall allow observation of the liquid level and consistency.

**11.4.2.5** Humidifiers and nebulizers shall be equipped with provisions for overpressure relief or alarm if the flow becomes obstructed.

**11.4.2.6** Humidifiers and nebulizers shall be incapable of tipping or shall be mounted so that any tipping or alteration from the vertical shall not interfere with function or accuracy.

##### **11.4.3 Nonpatient Gas Equipment.**

###### **11.4.3.1 Carts and Hand Trucks.**

**11.4.3.1.1 Construction.** Carts and hand trucks for cylinders and containers shall be constructed for the intended purpose, be self-supporting, and be provided with appropriate chains or stays to retain cylinders or containers.

###### **11.4.3.2 Gas Equipment — Laboratory.**

**11.4.3.2.1** Gas appliances shall be of an approved design and installed in accordance with NFPA 54, *National Fuel Gas Code*.

**11.4.3.2.2** Shutoff valves shall be legibly marked to identify the material they control.

**11.4.3.3\*** Medical devices not for patient care and requiring oxygen USP shall meet the following:

- (1) Be listed for the intended purpose by the United States Food & Drug Administration
- (2) Be under the direction of a licensed medical professional, if connected to the piped distribution system
- (3) Not be permanently attached to the piped distribution system
- (4) Be installed and used per the manufacturer's instructions
- (5) Be equipped with a backflow prevention device

#### **11.5 Administration.**

##### **11.5.1 Policies.**

###### **11.5.1.1 Elimination of Sources of Ignition.**

**11.5.1.1.1** Smoking materials (e.g., matches, cigarettes, lighters, lighter fluid, tobacco in any form) shall be removed from patients receiving respiratory therapy.

**11.5.1.1.2\*** No sources of open flame, including candles, shall be permitted in the area of administration.

**11.5.1.1.3\*** Sparking toys shall not be permitted in any patient care room.

**11.5.1.1.4** Nonmedical appliances that have hot surfaces or sparking mechanisms shall not be permitted within oxygen-delivery equipment or within the site of intentional expulsion.

###### **11.5.1.2 Misuse of Flammable Substances.**

**11.5.1.2.1** Flammable or combustible aerosols or vapors, such as alcohol, shall not be used in oxygen-enriched atmospheres.

**11.5.1.2.2** Oil, grease, or other flammable substances shall not be used on/in oxygen equipment.

**11.5.1.2.3** Flammable and combustible liquids shall not be permitted within the site of intentional expulsion.

###### **11.5.1.3 Servicing and Maintenance of Equipment.**

**11.5.1.3.1** Defective equipment shall be immediately removed from service.



**11.5.1.3.2** Defective electrical apparatus shall not be used.

**11.5.1.3.3** Areas designated for the servicing of oxygen equipment shall be clean and free of oil, grease, or other flammable substances.

**11.5.1.3.4** Service manuals, instructions, and procedures provided by the manufacturer shall be used in the maintenance of equipment.

**11.5.1.3.5** A scheduled preventive maintenance program shall be followed.

**11.5.2 Gases in Cylinders and Liquefied Gases in Containers.**

**11.5.2.1 Qualification and Training of Personnel.**

**11.5.2.1.1\*** Personnel concerned with the application and maintenance of medical gases and others who handle medical gases and the cylinders that contain the medical gases shall be trained on the risks associated with their handling and use.

**11.5.2.1.2** Health care facilities shall provide programs of continuing education for their personnel.

**11.5.2.1.3** Continuing education programs shall include periodic review of safety guidelines and usage requirements for medical gases and their cylinders.

**11.5.2.1.4** Equipment shall be serviced only by personnel trained in the maintenance and operation of the equipment.

**11.5.2.1.5** If a bulk cryogenic system is present, the supplier shall provide annual training on its operation.

**11.5.2.2 Transfilling Cylinders.**

**11.5.2.2.1** Mixing of compressed gases in cylinders shall be prohibited.

**11.5.2.2.2** Transfilling of gaseous oxygen from one cylinder to another shall be in accordance with CGA P-2.5, *Transfilling of High Pressure Gaseous Oxygen to be Used for Respiration*.

**11.5.2.2.3** Transfilling of any gases from one cylinder to another in patient care rooms of health care facilities shall be prohibited.

**11.5.2.3 Transfilling Liquid Oxygen.** Transfilling of liquid oxygen shall comply with 11.5.2.3.1 or 11.5.2.3.2, as applicable.

**11.5.2.3.1** Transfilling to liquid oxygen base reservoir containers or to liquid oxygen portable containers over 344.74 kPa (50 psi) shall include the following:

- (1) A designated area separated from any portion of a facility wherein patients are housed, examined, or treated by a fire barrier of 1 hour fire-resistive construction.
- (2) The area is mechanically ventilated, is sprinklered, and has ceramic or concrete flooring.
- (3) The area is posted with signs indicating that transfilling is occurring and that smoking in the immediate area is not permitted.
- (4) The individual transfilling the container(s) has been properly trained in the transfilling procedures.

**11.5.2.3.2** Transfilling to liquid oxygen portable containers at 344.74 kPa (50 psi) and under shall include the following:

- (1) The area is well ventilated and has noncombustible flooring.
- (2) The area is posted with signs indicating that smoking in the area is not permitted.

(3) The individual transfilling the liquid oxygen portable container has been properly trained in the transfilling procedure.

(4) The guidelines of CGA P-2.6, *Transfilling of Low-Pressure Liquid Oxygen to be Used for Respiration*, are met.

**11.5.2.4 Ambulatory Patients.** Ambulatory patients on oxygen therapy shall be permitted access to all flame- and smoke-free areas within the health care facility.

**11.5.3 Use (Including Information and Warning Signs).**

**11.5.3.1 Labeling.**

**11.5.3.1.1** Equipment listed for use in oxygen-enriched atmospheres shall be so labeled.

**11.5.3.1.2** Oxygen-metering equipment and pressure reducing regulators shall be conspicuously labeled as follows:

**OXYGEN — USE NO OIL**

**11.5.3.1.3** Flowmeters, pressure reducing regulators, and oxygen-dispensing apparatus shall be clearly and permanently labeled, designating the gas or mixture of gases for which they are intended.

**11.5.3.1.4** Apparatus whose calibration or function is dependent on gas density shall be labeled as to the proper supply gas gauge pressure (kPa/psi) for which it is intended.

**11.5.3.1.5** Oxygen-metering equipment, pressure reducing regulators, humidifiers, and nebulizers shall be labeled with the name of the manufacturer or supplier.

**11.5.3.1.6** Cylinders and containers shall be labeled in accordance with CGA C-7, *Guide to the Preparation of Precautionary Labeling and Marking of Compressed Gas Containers*. Color coding shall not be utilized as a primary method of determining cylinder or container content.

**11.5.3.1.7** All labeling shall be durable and withstand cleansing or disinfection.

**11.5.3.2\* Signs.**

**11.5.3.2.1** In health care facilities where smoking is not prohibited, precautionary signs readable from a distance of 1.5 m (5 ft) shall be conspicuously displayed wherever supplemental oxygen is in use and in aisles and walkways leading to such an area.

**11.5.3.2.2** The signs shall be attached to adjacent doorways or to building walls or be supported by other appropriate means.

**11.5.3.2.3** In health care facilities where smoking is prohibited and signs are prominently (strategically) placed at all major entrances, secondary signs with no smoking language shall not be required.

**11.5.3.2.4** The nonsmoking policies shall be strictly enforced.

**11.5.3.3 Transportation, Storage, and Use of Equipment.**

**11.5.3.3.1** Flow-control valves on administering equipment shall be closed prior to connection and when not in use.

**11.5.3.3.2** Apparatus shall not be stored or transported with liquid agents in reservoirs.

**11.5.3.3.3** Care shall be taken in attaching connections from gas services to equipment and from equipment to patients.

**11.5.3.3.4** Fixed or adjustable orifice mechanisms, metering valves, pressure reducing regulators, and gauges shall not be connected directly to high pressure cylinders, unless specifically listed for such use and provided with appropriate safety devices.

**11.5.3.3.5** Equipment shall only be serviced by qualified personnel.

## **11.6 Operation and Management of Cylinders.**

**11.6.1 Administration.** Administrative authorities of health care organizations shall provide policies and procedures for safe practices.

**11.6.1.1** Purchase specifications shall include the following:

- (1) Specifications for cylinders
- (2) Marking of cylinders, regulators, and valves
- (3) Proper connections on the cylinders supplied to the facility

**11.6.1.2** Training procedures shall include the following:

- (1) Maintenance programs in accordance with the manufacturer's recommendations for the piped gas system
- (2) Use and transport of equipment and the proper handling of cylinders, containers, hand trucks, supports, and valve protection caps
- (3) Verification of gas content and mechanical connection specificity of each cylinder or container prior to placing it into service

**11.6.1.3** Policies for enforcement shall include the following:

- (1) Regulations for the storage and handling of cylinders and containers of oxygen and nitrous oxide
- (2) Prompt evaluation of all signal warnings and all necessary measures taken to re-establish the proper functions of the medical gas and vacuum systems
- (3) Organizational capability and resources to cope with a complete loss of any medical gas or vacuum system
- (4) Successful completion of all tests required in 5.1.12.3 prior to the use of any medical gas or vacuum piping system for patient care
- (5) Locations intended for the delivery vehicle delivering cryogenic liquid to bulk cryogenic liquid systems to remain open and not be used for any other purpose (e.g., vehicle parking, storage of trash containers)

**11.6.2 Special Precautions for Handling Oxygen Cylinders and Manifolds.** Handling of oxygen cylinders and manifolds shall be based on CGA G-4, *Oxygen*.

**11.6.2.1** Oxygen cylinders, containers, and associated equipment shall be protected from contact with oil or grease by means of the following specific precautions:

- (1) Oil, grease, or readily flammable materials shall not be permitted to come in contact with oxygen cylinders, valves, pressure reducing regulators, gauges, or fittings.
- (2) Pressure reducing regulators, fittings, or gauges shall not be lubricated with oil or any other flammable substance.
- (3) Oxygen cylinders or apparatus shall not be handled with oily or greasy hands, gloves, or rags.

**11.6.2.2** Equipment associated with oxygen shall be protected from contamination by means of the following specific precautions:

- (1) Particles of dust and dirt shall be cleared from cylinder valve openings by slightly opening and closing the valve before applying any fitting to the cylinder valve.
- (2) The high pressure valve on the oxygen cylinder shall be opened slowly before bringing the apparatus to the patient or the apparatus to the patient.
- (3) An oxygen cylinder shall not be draped with any materials such as hospital gowns, masks, or caps.

- (4) Cylinder-valve protection caps, where provided, shall be kept in place and be hand-tightened, except when cylinders are in use or connected for use.
- (5) Valves shall be closed on all empty cylinders in storage.

**11.6.2.3** Cylinders shall be protected from damage by means of the following specific procedures:

- (1) Oxygen cylinders shall be protected from abnormal mechanical shock, which is liable to damage the cylinder, valve, or safety device.
- (2) Oxygen cylinders shall not be stored near elevators or gangways or in locations where heavy moving objects will strike them or fall on them.
- (3) Cylinders shall be protected from tampering by unauthorized individuals.
- (4) Cylinders or cylinder valves shall not be repaired, painted, or altered.
- (5) Safety relief devices in valves or cylinders shall not be tampered with.
- (6) Valve outlets clogged with ice shall be thawed with warm — not boiling — water.
- (7) A torch flame shall not be permitted, under any circumstances, to come in contact with a cylinder, cylinder valve, or safety device.
- (8) Sparks and flame shall be kept away from cylinders.
- (9) Even if they are considered to be empty, cylinders shall not be used as rollers, supports, or for any purpose other than that for which the supplier intended them.
- (10) Large cylinders (exceeding size E) and containers larger than 45 kg (100 lb) weight shall be transported on a proper hand truck or cart complying with 11.4.3.1.
- (11) Freestanding cylinders shall be properly chained or supported in a proper cylinder stand or cart.
- (12) Cylinders shall not be supported by radiators, steam pipes, or heat ducts.

**11.6.2.4** Cylinders and their contents shall be handled with care, which shall include the following specific procedures:

- (1) Oxygen fittings, valves, pressure reducing regulators, or gauges shall not be used for any service other than that of oxygen.
- (2) Gases of any type shall not be mixed in an oxygen cylinder or any other cylinder.
- (3) Oxygen shall always be dispensed from a cylinder through a pressure reducing regulator.
- (4) The cylinder valve shall be opened slowly, with the face of the indicator on the pressure reducing regulator pointed away from all persons.
- (5) Oxygen shall be referred to by its proper name, *oxygen*, not air, and liquid oxygen shall be referred to by its proper name, not liquid air.
- (6) Oxygen shall not be used as a substitute for compressed air.
- (7) The markings stamped on cylinders shall not be tampered with, because it is against federal statutes to change these markings.
- (8) Markings used for the identification of contents of cylinders shall not be defaced or removed, including decals, tags, and stenciled marks, except those labels/tags used for indicating cylinder status (e.g., full, in use, empty).
- (9) The owner of the cylinder shall be notified if any condition has occurred that might allow any foreign substance to enter a cylinder or valve, giving details and the cylinder number.

- (10) Neither cylinders nor containers shall be placed in the proximity of radiators, steam pipes, heat ducts, or other sources of heat.
- (11) Very cold cylinders or containers shall be handled with care to avoid injury.

**11.6.2.5** Oxygen equipment that is defective shall not be used until one of the following tasks has been performed:

- (1) It has been repaired by competent in-house personnel.
- (2) It has been repaired by the manufacturer or his or her authorized agent.
- (3) It has been replaced.

**11.6.2.6** Pressure reducing regulators that are in need of repair or cylinders having valves that do not operate properly shall not be used.

**11.6.3 Special Precautions for Making Cylinder and Container Connections.**

**11.6.3.1** Cylinder valves shall be opened and connected in accordance with the following procedure:

- (1) Make certain that apparatus and cylinder valve connections and cylinder wrenches are free of foreign materials.
- (2) Turn the cylinder valve outlet away from personnel following these safety procedures:
  - (a) Stand to the side — not in front and not in back.
  - (b) Before connecting the apparatus to the cylinder valve, momentarily open the cylinder valve to eliminate dust.
- (3) Make connection of the apparatus to the cylinder valve, and tighten the connection nut securely with a wrench.
- (4) Release the low pressure adjustment screw of the pressure reducing regulator completely.
- (5) Slowly open cylinder valve to the full-open position.
- (6) Slowly turn in the low pressure adjustment screw on the pressure reducing regulator until the proper working pressure is obtained.
- (7) Open the valve to the utilization apparatus.

**11.6.3.2** Connections for containers shall be made in accordance with the container manufacturer's operating instructions.

**11.6.4 Special Precautions for the Care of Safety Mechanisms.**

**11.6.4.1** Personnel using cylinders and containers and other equipment covered in this chapter shall be familiar with the CGA Pin-Index Safety System and the CGA Diameter-Index Safety System, which are both designed to prevent utilization of the wrong gas.

**11.6.4.2** Safety relief mechanisms, noninterchangeable connectors, and other safety features shall not be removed, altered, or replaced.

**11.6.5 Special Precautions — Storage of Cylinders and Containers.**

**11.6.5.1** Storage shall be planned so that cylinders can be used in the order in which they are received from the supplier.

**11.6.5.2** If empty and full cylinders are stored within the same enclosure, empty cylinders shall be segregated from full cylinders.

**11.6.5.2.1** When the facility employs cylinders with integral pressure gauge, it shall establish the threshold pressure at which a cylinder is considered empty.

**11.6.5.3** Empty cylinders shall be marked to avoid confusion and delay if a full cylinder is needed in a rapid manner.

**11.6.5.4** Cylinders stored in the open shall be protected as follows:

- (1) Against extremes of weather and from the ground beneath to prevent rusting
- (2) During winter, against accumulations of ice or snow
- (3) During summer, screened against continuous exposure to direct rays of the sun in those localities where extreme temperatures prevail

**11.7 Liquid Oxygen Equipment.**

**11.7.1 General.** The storage and use of liquid oxygen in liquid oxygen base reservoir containers and liquid oxygen portable containers shall comply with the following, or storage and use shall be in accordance with the adopted fire prevention code.

**11.7.2 Information and Instructions.** The liquid oxygen seller shall provide the user with documentation that includes, but is not limited to, the following:

- (1) Manufacturer's instructions, including labeling for storage and use of the containers
- (2) Requirements for storage and use of containers away from ignition sources, exits, electrical hazards, and high-temperature devices
- (3) Methods for container restraint to prevent falling
- (4) Requirements for container handling
- (5) Safeguards for refilling of containers

**11.7.3 Container Storage, Use, and Operation.**

**11.7.3.1\*** Containers shall be stored, used, and operated in accordance with the manufacturer's instructions and labeling.

**11.7.3.2** Containers shall not be placed in the following areas:

- (1) Where they can be tipped over by the movement of a door
- (2) Where they interfere with foot traffic
- (3) Where they are subject to damage from falling objects
- (4) Where exposed to open flames and high-temperature devices

**11.7.3.3\*** Liquid oxygen base reservoir containers shall be secured by one of the following methods while in storage or use to prevent tipping over caused by contact, vibration, or seismic activity:

- (1) Securing to a fixed object with one or more restraints
- (2) Securing within a framework, stand, or assembly designed to resist container movement
- (3) Restraining by placing the container against two points of contact

**11.7.3.4** Liquid oxygen base reservoir containers shall be transported by a cart or hand truck designed for such use, unless a container is equipped with a roller base.

**11.7.3.5** The transfilling of containers shall be in accordance with the manufacturer's instructions and the requirements of 11.7.3.5.1 through 11.7.3.5.2.

**11.7.3.5.1** Liquid oxygen containers shall be filled outdoors or in compliance with 11.5.2.3.1.

**11.7.3.5.1.1\*** A drip pan compatible with liquid oxygen shall be provided under the liquid oxygen base reservoir container's filling and vent connections used during the filling process, unless the filling is performed on a noncombustible surface such as concrete.

**11.7.3.5.2** Liquid oxygen portable containers shall be permitted to be filled indoors when the liquid oxygen base reservoir container is designed for filling such containers and the written instructions provided by the container manufacturer are followed.

**11.7.4 Maximum Quantity.** The maximum total quantity of liquid oxygen permitted in storage and in use in a patient bed location or patient care room shall be 120 L (31.6 gal), provided that the patient bed location or patient care room, or both, are separated from the remainder of the facility by fire barriers and horizontal assemblies having a minimum fire resistance rating of 1 hour in accordance with the adopted building code.

## Chapter 12 Emergency Management

**12.1\* Scope.** This chapter shall provide those with the responsibility for emergency management in new and existing health care facilities with the criteria to develop an emergency management program.

### 12.1.1\* General.

**12.1.1.1** This chapter shall provide those with the responsibility for emergency management in health care facilities with the criteria to assess, mitigate, prepare for, respond to, and recover from emergencies of any origin.

**12.1.1.2** This chapter shall be the source for emergency management in health care facilities and is based on the foundations of *NFPA 1600, Standard on Disaster/Emergency Management and Business Continuity Programs*.

**12.1.1.3** This chapter shall aid in developing, maintaining, and evaluating effective emergency management programs in new and existing facilities.

**12.1.2 Applicability.** This chapter shall be applicable to any health care facility that is intended to provide medical care during an emergency or maintain services for patients during a disaster and for the protection of visitors and staff.

### 12.2 Responsibilities.

#### 12.2.1\* Authority Having Jurisdiction.

**12.2.1.1** The authority having jurisdiction shall be cognizant of the requirements of a health care facility with respect to its uniqueness for continued operation of the facility in an emergency.

**12.2.1.2** The authority having jurisdiction shall ensure health care facility emergency management programs meet the requirements of this chapter.

#### 12.2.2 Senior Management.

**12.2.2.1** The senior management shall actively participate in and support emergency management planning.

**12.2.2.2** Senior management shall provide the required resources to develop and support the emergency management program.

**12.2.2.3** Senior management shall appoint a program coordinator.

**12.2.3\* Emergency Management Committee.** The emergency management committee shall include representatives of senior management and clinical and support services.

**12.2.3.1** The membership of the emergency management committee shall include a chairperson, the emergency program coordinator, a member of senior management, nursing, and representatives from key areas within the organization,

such as physicians, infection control, facilities engineering, safety/industrial hygiene, security, and other key individuals.

**12.2.3.2** The emergency management committee shall have the responsibility for the emergency management program within the facility.

**12.2.3.3\*** The emergency management committee shall model the emergency operations plan on an incident command system (ICS) in coordination with federal, state, and local emergency response agencies, as applicable.

**12.3 Matrix Categories.** The application of requirements in this chapter shall be based on the category of the health care facility as defined in Table 12.3.

**Table 12.3 Application Matrix**

Category	Definition
1	Those inpatient facilities that remain operable to provide advanced life support services to injured responders and disaster victims. These facilities manage the existing inpatient load as well as plan for the influx of additional patients as a result of an emergency.
2	Those inpatient or outpatient facilities that augment the critical mission. These facilities manage the existing inpatient or outpatient loads but do not plan to receive additional patients as a result of an emergency.

### 12.4 General.

**12.4.1** Health care facilities shall develop an emergency management program with a documented emergency operations plan based on the category of the health care facility as defined in Table 12.3.

**12.4.1.1** The emergency management program shall include elements as required to manage an emergency during all four phases: mitigation, preparedness, response, and recovery.

**12.4.1.2** The emergency management program shall comply with applicable regulations, directives, policies, and industry standards of practice.

**12.4.2** When developing its emergency management program, the facility shall communicate its needs and vulnerabilities to community emergency response agencies and identify the capabilities of its community in supporting their mission.

**12.4.3** The medical facility, in combination with the local or federal authorities, or both, shall establish the required category as defined in Table 12.3.

#### 12.5 Category 1 and Category 2 Requirements.

**12.5.1** All Category 1 and Category 2 health care facilities shall be required to develop and maintain an emergency management program that addresses all program elements as prescribed in 12.5.2 and 12.5.3.

**12.5.2** The elements and complexity of the subsequent code sections in this chapter shall apply, as appropriate to the hazard vulnerability analysis (HVA), the community's expectations, and the leadership's defined mission of the health care facility.

### 12.5.3 Program Elements.

#### 12.5.3.1 Hazard Vulnerability Analysis (HVA).

**12.5.3.1.1** A hazard vulnerability analysis (HVA) shall be conducted to identify and prioritize hazards that pose a threat to the facility and can affect the demand for its services.

**12.5.3.1.2\*** The hazards to be considered shall include, but not be limited to, the following:

- (1) Natural hazards (geological, meteorological, and biological)
- (2) Human-caused events (accidental or intentional)
- (3) Technological events

**12.5.3.1.3** The analysis shall include the potential impact of the hazards on conditions including, but not limited to, the following:

- (1)\*Continuity of operations
- (2) Care for new and existing patients/residents/clients
- (3) Health, safety, and security of persons in the affected area
- (4) Support of staff
- (5) Property, facilities, and infrastructure
- (6) Environmental impact
- (7) Economic and financial conditions
- (8) Regulatory and contractual obligations
- (9) Reputation of, or confidence in, the facility

**12.5.3.1.4** The facility shall prioritize the hazards and threats identified in the HVA with input from the community.

#### 12.5.3.2 Mitigation.

**12.5.3.2.1** The facility shall develop and implement a strategy to eliminate hazards or mitigate the effects of hazards that cannot be eliminated.

**12.5.3.2.2** A mitigation strategy shall be developed for priority hazards defined by the HVA.

**12.5.3.2.3** The mitigation strategy shall consider, but not be limited to, the following:

- (1) Use of applicable building construction standards
- (2) Hazard avoidance through appropriate land-use practices
- (3) Relocation, retrofitting, or removal of structures at risk
- (4) Removal or elimination of the hazard
- (5) Reduction or limitation of the amount or size of the hazard
- (6) Segregation of the hazard from that which is to be protected
- (7) Modification of the basic characteristics of the hazard
- (8) Control of the rate of release of the hazard
- (9) Provision of protective systems or equipment for both cyber or physical risks
- (10) Establishment of hazard warning and communications procedures
- (11) Redundancy or duplication of essential personnel, critical systems, equipment, information, operations, or materials

#### 12.5.3.3 Preparedness.

**12.5.3.3.1** The facility shall prepare for any emergency as determined by the HVA by organizing and mobilizing essential resources.

**12.5.3.3.2** The facility shall maintain a current, documented inventory of the assets and resources it has on-site that would be needed during an emergency, such as medical, surgical, and pharmaceutical resources; water; fuel; staffing; food; and linen.

**12.5.3.3.3** The facility shall identify the resource capability shortfalls from 96 hours of sustainability and determine if mitigation activities are necessary and feasible.

**12.5.3.3.4** The facility shall establish a protocol for monitoring the quantity of assets and resources as they are utilized.

**12.5.3.3.5** The facility shall write an emergency operations plan (EOP) that describes a command structure and the following critical functions within the facility during an emergency:

- (1) Communications
- (2) Resources and assets
- (3) Safety and security
- (4) Clinical support activities
- (5) Essential utilities
- (6) Exterior connections
- (7) Staff roles

**12.5.3.3.6 Critical Function Strategies.** During the development of the EOP, the facility shall consider the strategies required in 12.5.3.3.6.1 through 12.5.3.3.6.8 in order to manage critical functions during an emergency within the facility.

**12.5.3.3.6.1 Communications.** The facility shall plan for the following during an emergency:

- (1) Initial notification and ongoing communication of information and instructions to staff
- (2) Initial notification and ongoing communication with the external authorities
- (3) Communication with the following:
  - (a) Patients and their families (responsible parties)
  - (b) Responsible parties when patients are relocated to alternative care sites
  - (c) Community and the media
  - (d) Suppliers of essential materials, services, and equipment
  - (e) Alternative care sites
- (4) Definition of when and how to communicate patient information to third parties
- (5)\*Establishment of backup communications systems
- (6) Cooperative planning with other local or regional health care facilities, including the following:
  - (a) Exchange of information relating to command operations, including contact information
  - (b) Staffing and supplies that could be shared
  - (c) System to locate the victims of the event

**12.5.3.3.6.2 Resources and Assets.** The facility shall plan for the following during an emergency:

- (1) Acquiring medical, pharmaceutical, and nonmedical supplies
- (2) Replacing medical supplies and equipment that will be used throughout response and recovery
- (3) Replacing pharmaceutical supplies that will be consumed throughout response and recovery
- (4) Replacing nonmedical supplies that will be depleted throughout response and recovery
- (5) Managing staff support activities, such as housing, transportation, incident stress debriefing, sanitation, hydration, nutrition, comfort, morale, and mental health
- (6) Managing staff family support needs, such as child care, elder care, pet care, and communication to home
- (7) Providing staff, equipment, and transportation vehicles needed for evacuation

**12.5.3.3.6.3\* Safety and Security.** The facility shall plan for the following during an emergency:

- (1) Internal security and safety operations
- (2) Roles of agencies such as police, sheriff, and national guard
- (3) Managing hazardous materials and waste
- (4) Radioactive, biological, and chemical isolation and decontamination
- (5) Patients susceptible to wandering
- (6) Controlling entrance into the health care facility during emergencies
- (7) Conducting a risk assessment with applicable authorities if it becomes necessary to control egress from the health care facility
- (8) Controlling people movement within the health care facility
- (9) Controlling traffic access to the facility

**12.5.3.3.6.4 Clinical Support Activities.** The facility shall plan for the following during an emergency:

- (1) Clinical activities that could need modification or discontinuation during an emergency, such as patient scheduling, triage, assessment, treatment, admission, transfer, discharge, and evacuation
- (2) Clinical services for special needs populations in the community, such as pediatric, geriatric, disabled, chronically ill patients and those with addictions (Category 1 only)
- (3) Patient cleanliness and sanitation
- (4) Behavioral needs of patients
- (5) Mortuary services
- (6) Evacuation both horizontally and, when required by circumstances, vertically, when the environment cannot support care, treatment, and services
- (7) Transportation of patients, and their medications and equipment, and staff to an alternative care site(s) when the environment cannot support care, treatment, and services
- (8) Transportation of pertinent patient information, including essential clinical and medication-related information, to an alternative care site(s) when the environment cannot support care, treatment, and services
- (9) Documentation and tracking of patient location and patient clinical information

**12.5.3.3.6.5\* Essential Utilities.** The facility shall plan for the following during an emergency:

- (1) Electricity
- (2) Potable water
- (3) Nonpotable water
- (4) HVAC
- (5) Fire protection systems
- (6) Fuel required for building operations
- (7) Fuel for essential transportation
- (8) Medical gas and vacuum systems (if applicable)

**12.5.3.3.6.6 Exterior Connections.** For essential utility systems in Category 1 facilities only, and based on the facility's HVA, consideration shall be given to the installation of exterior building connectors to allow for the attachment of portable emergency utility modules.

**12.5.3.3.6.7 Staff Roles.**

(A) Staff roles shall be defined for the areas of communications, resources and assets, safety and security, essential utilities, and clinical activities.

(B) Staff shall receive training for their assigned roles in the EOP.

(C) The facility shall communicate to licensed independent health care providers their roles in the EOP.

(D) The facility shall provide staff and other personnel with a form of identification, such as identification cards, wrist bands, vests, hats, badges, or computer printouts.

(E) The facility shall include in its plan the alerting and managing of all staff in an emergency.

**12.5.3.3.6.8** The facility shall include the following in its EOP:

- (1)\*Standard command structure that is consistent with its community
- (2) Reporting structure consistent with the command structure
- (3) Activation and deactivation of the response and recovery phases, including the authority and process
- (4) Facility capabilities and appropriate response efforts when the facility cannot be supported from the outside for extended periods in the six critical areas with an acceptable response, including examples such as the following:
  - (a) Resource conservation
  - (b) Service curtailment
  - (c) Partial or total evacuation consistent with the staff's designated role in community response plan
- (5) Alternative treatment sites to meet the needs of the patients

**12.5.3.3.7 Staff Education.**

**12.5.3.3.7.1** Each facility shall implement an educational program in emergency management.

**12.5.3.3.7.2** The educational program shall include an overview of the components of the emergency management program and concepts of the ICO.

**12.5.3.3.7.3** Individuals who are expected to perform as incident commanders or to be assigned to specific positions within the command structure shall be trained in and familiar with the ICO and the particular levels at which they are expected to perform.

**12.5.3.3.7.4** Education concerning the staff's specific duties and responsibilities shall be conducted.

**12.5.3.3.7.5** General overview education of the emergency management program and the ICO shall be conducted at the time of hire.

**12.5.3.3.7.6** Department-/staff-specific education shall be conducted upon appointment to department/staff assignments or positions and annually thereafter.

**12.5.3.3.8\* Testing Emergency Plans and Operations.**

**12.5.3.3.8.1** The facility shall test its EOP at least twice annually, either through functional or full-scale exercises or actual events.

**12.5.3.3.8.2** Exercises shall be based on the HVA priorities and be as realistic as feasible.

**12.5.3.3.8.3** For Category 1 only, an influx of volunteer or simulated patients shall be tested annually, either through a functional or full-scale exercise or an actual event. (See Table 12.3.)

**12.5.3.3.8.4** Annual table top, functional, or full-scale exercises shall include the following:

- (1) Community integration
- (2) Assessment of stand-alone capability

**12.5.3.3.8.5** For Category 1 only, if so required by the community designation to receive infectious patients, the facility shall conduct at least one exercise a year that includes a surge of infectious patients. (See Table 12.3.)

**12.5.3.3.8.6** The identified exercises shall be conducted independently or in combination.

**12.5.3.3.9 Scope of Exercises.**

**12.5.3.3.9.1** Exercises shall be monitored by at least one designated evaluator who has knowledge of the facility's plan and who is not involved in the exercise.

**12.5.3.3.9.2** Exercises shall monitor the critical functions.

**12.5.3.3.9.3** The facility shall conduct a debriefing session not more than 72 hours after the conclusion of the exercise or the event.

**12.5.3.3.9.4** The debriefing shall include all key individuals, including observers; administration; clinical staff, including a physician(s); and appropriate support staff.

**12.5.3.3.9.5** Exercises and actual events shall be critiqued to identify areas for improvement.

**12.5.3.3.9.6** The critiques required by 12.5.3.3.9.5 shall identify deficiencies and opportunities for improvement based upon monitoring activities and observations during the exercise.

**12.5.3.3.9.7** Opportunities for improvement identified in critiques shall be incorporated in the facility's improvement plan.

**12.5.3.3.9.8** The facility shall modify its EOP in response to critiques of exercises.

**12.5.3.3.9.9\*** Improvements made to the EOP shall be evaluated in subsequent exercises.

**12.5.3.4 Response.**

**12.5.3.4.1\*** The facility shall declare itself in an emergency mode based on current conditions that leadership considers extraordinary.

**12.5.3.4.2** Once an emergency mode has been declared, the facility shall activate its EOP.

**12.5.3.4.3** The decision to activate the EOP shall be made by the incident commander designated within the plan, in accordance with the facility's activation criteria.

**12.5.3.4.4** The decision to deactivate the EOP shall be made by the incident commander in the health care organization in coordination with the applicable external command authority.

**12.5.3.4.5\*** The organization shall make provisions for emergency credentialing of volunteer clinical staff.

**12.5.3.4.5.1** At a minimum, a peer evaluation of skill shall be conducted to validate proficiency for volunteer clinical staff.

**12.5.3.4.5.2** Prior to beginning work, efforts shall be made to verify identities of other volunteers offering to assist during response activities.

**12.5.3.4.5.3** Personnel designated or involved in the EOP of the health care facility shall be supplied with a means of identification, which shall be worn at all times in a visible location.

**12.5.3.4.6** The command staff shall actively monitor conditions present in the environment and remain in communication with community emergency response agencies during an emergency response.

**12.5.3.4.7** When conditions approach untenable, the command staff, in combination with community emergency response agencies, shall determine when to activate the facility evacuation plan.

**12.5.3.4.8** Evacuation to the alternative care site shall follow the planning conducted during the preparedness phase.

**12.5.3.4.9** Planning efforts shall minimize to the greatest extent feasible the planned reduction of clinical care.

**12.5.3.4.10** The decision to reduce medical care shall be conducted with the full knowledge and concurrence of community leadership.

**12.5.3.4.11** Upon implementation of a controlled reduction in medical care, the following shall be considered:

- (1) The triage process shall be modified during an emergency.
- (2) Medical services shall be allocated to prevent the most deaths in the entire population of patients.

**12.5.3.4.12 Surge Capacity of Victims.** The requirements of 12.5.3.4.12.1 and 12.5.3.4.12.2 shall apply only to those facilities designated as Category 1 as defined by the HVA.

**12.5.3.4.12.1** The facility shall plan for surge capacity.

**12.5.3.4.12.2** The triage process shall be implemented as follows:

- (1) The arriving victim shall be assessed into the following cohorts:
  - (a) Risk to others, as follows:
    - i. Mentally unstable
    - ii. Contaminated
    - iii. Infectious
  - (b) Risk to self, as follows:
    - i. Emotionally impaired
    - ii. Suicidal
  - (c) Risk of death or permanent injury, as follows:
    - i. Walking wounded
    - ii. Severely injured but stable
    - iii. Suffering from life-threatening injury
    - iv. Beyond care
- (2) Patients shall be admitted for treatment depending on facility capacity, the facility's specialty, and clinical need.
- (3) Creation of ancillary clinical space shall have adequate utility support for the following:
  - (a) HVAC
  - (b) Sanitation
  - (c) Lighting
  - (d) Proximity to operating room (OR)

**12.5.3.4.13** Recovery from controlled reduction in care standards shall be reversed at the earliest feasible time.

**12.5.3.4.14** Health care facilities shall have a designated media spokesperson to facilitate news releases during the response process.

**12.5.3.4.15** An area shall be designated for media representatives to assemble where they will not interfere with the operations of the health care facility.

**12.5.3.5\* Recovery.**

**12.5.3.5.1** Plans shall reflect measures needed to restore operational capability to pre-disaster levels.

**12.5.3.5.2** Fiscal aspects shall be considered with respect to restoration costs and possible cash flow losses associated with the disruption.

**12.5.3.5.3** Facility leadership shall accept and accommodate federal, state, and local assistance that will be beneficial for recovery of operations.

**12.5.3.5.4** No party to recovery shall take action to unfairly limit lawful competition once recovery operations are completed.

**12.5.3.5.5** Recovery shall not be deemed complete until infection control decontamination efforts are validated.

**12.5.3.6 Administration.**

**12.5.3.6.1** The facility shall update its emergency management program annually, which shall include the following:

- (1) Updates to the facility HVA
- (2) Updates to the facility EOP

**12.5.3.6.2** The facility shall maintain written records of drills, exercises, and training as required by this chapter for a period of 3 years.

## Chapter 13 Security Management

**13.1\* Scope.** This chapter shall provide those with the responsibility for security in new and existing health care facilities with the criteria to develop a security management program.

**13.1.1\*** A health care facility shall have a security management plan.

**13.1.2\*** The scope, objectives, performance, and effectiveness of the security plan shall be tested at a frequency shown to be necessary by review of the security vulnerability assessment (SVA) in accordance with Section 13.2.

**13.2 Security Vulnerability Assessment (SVA).**

**13.2.1\*** The health care facility shall conduct a security vulnerability assessment (SVA).

**13.2.2** The SVA shall evaluate the potential security risks posed by the physical and operational environment of the health care facility to all individuals in the facility.

**13.2.3** The facility shall implement procedures and controls in accordance with the risks identified by the SVA.

**13.3 Responsible Person.**

**13.3.1** A person(s) shall be appointed by the leadership of the health care facility to be responsible for all security management activities.

**13.3.2** The duties of the person assigned as required by 13.3.1 shall include, but not be limited to, the following, as identified in the SVA:

- (1) Provide identification for patients, staff, and other people entering the facility
- (2) Control access in and out of security-sensitive areas
- (3) Define and implement procedures as follows:
  - (a) Security incident
  - (b) Hostage situation
  - (c)\*Bomb (explosive device or threat)
  - (d) Criminal threat
  - (e) Labor action
  - (f) Disorderly conduct

- (g) Workplace violence
  - (h) Restraining order
  - (i) Prevention of, and response to, infant or pediatric abduction
  - (j) Situations involving VIPs or the media
  - (k) Maintenance of access to emergency areas
  - (l) Civil disturbance
  - (m) Forensic patients
  - (n) Patient elopement
  - (o) Homeland Security advisory system (threat level changes)
  - (p) Suspicious powder or substance
  - (q) Use of force policy
  - (r) Security staffing augmentation
- (4) Provide security at alternate care sites or vacated facilities
  - (5) Control vehicular traffic on the facility property
  - (6) Protect the facility assets, including property and equipment
  - (7) Provide policy for interaction with law enforcement agencies
  - (8) Comply with applicable laws, regulations, and standards regarding security management operations
  - (9) Educate and train the facility security force to address the following:
    - (a) Customer service
    - (b) Use of physical restraints
    - (c) Use of force
    - (d) Response criteria
    - (e) Fire watch procedures
    - (f) Lockdown procedures
    - (g) Emergency notification procedures
    - (h) Emergency communications procedures

**13.4 Security-Sensitive Areas.**

**13.4.1** All security-sensitive areas, as identified by the SVA, shall be protected as appropriate.

**13.4.2** Emergency department security shall include appropriate protection, including the following:

- (1)\*Control and limitation of access by the general public
- (2) Private duress alarm at the nurses' station and reception for summoning immediate assistance
- (3) Access-control of treatment area
- (4) Lockdown procedure to secure the area when conditions threaten the viability of the department
- (5) Bullet-resisting glazing material, as deemed necessary by review of the SVA

**13.4.3** Pediatric and infant care areas shall have a security plan for the prevention of, and response to, pediatric and infant abduction that shall include appropriate protections, such as the following:

- (1) Control and limitation of access by the general public
- (2) Screening by nursing prior to allowing persons access to infant care areas
- (3) Matching protocol with staff clearance to pair infants with parents
- (4) System to monitor and track the location of pediatric and infant patients
- (5)\*Facility alert system, lockdown, and staff inspection of all packages leaving the premises
- (6) Use of electronic monitoring, tracking, and access control equipment
- (7) Use of an automated and standardized facilitywide alerting system to announce pediatric or infant abduction
- (8) Remote exit locking or alarming



- (9) Facility lockdown procedures and staff inspection of all persons and packages leaving the premises
- (10) Prohibition on birth announcements by staff
- (11) Detection of the presence of nonidentified individual constitutes security breach
- (12) Movement of infants restricted to basinet only — no hand carries
- (13) Health care staff wear unique identification or uniforms
- (14) Secure storage of scrubs and uniforms, both clean and dirty
- (15) Education in pediatric and infant abduction as follows:
  - (a) Health care staff are familiar with infant abduction scenarios.
  - (b) Parents know not to leave a child or an infant unattended or in the care of an unidentified person.
- (16) Visiting family and friends not permitted to enter any nursery area with an infant or a newborn from the outside
- (17) Infant abduction drills conducted periodically to test effectiveness of chosen measures

**13.4.4\*** Medication storage and work areas shall be secured against admittance of unauthorized personnel through the use of the following:

- (1) Physical access control
- (2) Unique identification for the area
- (3) Secure storage and controlled dispensing of drugs

**13.4.5** Clinical and research laboratories shall be secured against admittance of unauthorized personnel through appropriate protections, such as the following:

- (1) Physical access control
- (2) Unique identification for the area
- (3) Secure storage and controlled dispensing of regulated chemical, biological, and radiological materials

**13.4.6** Dementia or behavioral health units shall be secured against the admittance or release of unauthorized personnel through appropriate protections, such as the following:

- (1) Physical access control
- (2) Unique identification for the area
- (3)\*Procedure to prevent entry of contraband prior to a person being admitted into the unit or department
- (4) Elopement precautions
- (5) Maintenance of color photos with the medical information of current patients to aid in identification

**13.4.7** Forensic patient treatment areas shall provide appropriate protections, such as the following:

- (1)\*Law enforcement attending the patient at all times
- (2) Treatment performed in an area separate from other patients
- (3) Restraints applied or removed only under forensic staff control

**13.4.8** Communications, data infrastructure, and medical records storage areas shall be secured against the admittance of unauthorized personnel or unauthorized release of confidential information through the use of appropriate protections, such as the following:

- (1) Physical access control
- (2) Unique identification for the area
- (3) Surveillance equipment
- (4) Data encryption and password protection

### **13.5 Access and Egress Security Measures.**

**13.5.1** Public visitation controls shall be enforced.

**13.5.2** After-hours entrance by the public shall be restricted to designated areas, such as entrance lobbies and emergency departments.

**13.5.3** Health care facility security controls and procedures shall comply with life safety requirements for egress.

**13.5.3.1\*** Security plans for health care occupancies shall address access and egress control during periods of quarantine and other events in conjunction with emergency agencies.

### **13.6\* Media Control.**

**13.6.1** The security management plan shall include procedures to accommodate media representatives.

**13.6.1.1\*** A person shall be designated to serve as media contact and representative for the organization in regard to media interactions.

**13.6.2\*** An area shall be designated for assembly of media representatives.

**13.6.3** A security or facility staff member shall remain with the media representative(s) at all times.

**13.6.4** Media representatives shall be escorted when granted access to the health care facility outside of the area designated in 13.6.1.1.

### **13.7\* Crowd Control.**

**13.7.1** The security management plan shall provide procedures for crowd control for management of those demanding access to a health care facility.

**13.7.2** The procedures for crowd control shall provide for the coordination and collaboration of security and law enforcement.

### **13.8 Security Equipment.**

**13.8.1** The security management plan shall provide procedures for crowd control demanding access to a health care facility.

**13.8.2** The security management plan shall include processes and procedures for controlling access to the health care facility.

**13.8.2.1** Exterior entrances shall be provided with locking devices.

**13.8.2.2** Locking devices shall comply with applicable federal, state, and local requirements.

**13.8.2.3** Locking devices shall be properly installed and be in good working order.

**13.8.3\*** The facility shall operate a key control program.

**13.9\* Employment Practices.** Employers shall ensure a high level of integrity in the workplace by using the following practices:

- (1) Background checks of employees with access to critical assets
- (2) Background checks of outside contractors' employees
- (3) Drug testing program for employees

### **13.10\* Security Operations.**

**13.10.1\*** Post orders shall be written for security personnel.

**13.10.2** Security personnel training shall include, but not be limited to, the following:

- (1) Customer service
- (2) Emergency procedures
- (3) Patrol methods
- (4) De-escalation training
- (5) Use of physical restraints
- (6) Use of force

### 13.11 Program Evaluation.

**13.11.1\*** Periodic drills shall be conducted at various times and locations.

**13.11.2** The drills shall be critiqued for plan effectiveness and to identify opportunities for improvement.

**13.11.3** Identified opportunities for improvement shall be incorporated into the security plan.

**13.11.4** The SVA and security plan shall be evaluated at least annually.

**13.11.5** The evaluation of the security management plan shall include a review of laws, regulations, and standards applicable to the security program.

## Chapter 14 Hyperbaric Facilities

**14.1\* Scope.** The scope of this chapter shall be as specified in 1.1.12.

### 14.1.1 Applicability.

**14.1.1.1** This chapter shall apply to new facilities.

**14.1.1.2** Portions of this chapter shall apply to existing facilities. (See 1.1.12.)

**14.1.1.3** This chapter shall also apply to the altered, renovated, or modernized portion of an existing system or individual component.

**14.1.1.4** Existing construction or equipment shall be permitted to be continued in use when such use does not constitute a distinct hazard to life.

### 14.1.2 Classification of Chambers.

**14.1.2.1 General.** Chambers shall be classified according to occupancy in order to establish appropriate minimum essentials in construction and operation.

**14.1.2.2\* Occupancy.** Hyperbaric chambers shall be classified according to the following criteria:

- (1) Class A — Human, multiple occupancy
- (2) Class B — Human, single occupancy
- (3) Class C — Animal, no human occupancy

### 14.2 Construction and Equipment.

#### 14.2.1 Housing for Hyperbaric Facilities.

**14.2.1.1** For Class A chambers located inside a building, the chamber(s) and all ancillary service equipment shall be protected by 2-hour fire-resistant-rated construction.

**14.2.1.1.1\*** Freestanding, dedicated buildings containing only a Class A chamber(s) and ancillary service equipment shall not be required to be protected by 2-hour fire-resistant-rated construction.

**14.2.1.1.2** Class B and C chambers located inside a building shall not be required to be protected by 2-hour fire-resistant-rated construction.

**14.2.1.1.3** Trailer or vehicle-mounted facilities shall be permitted without a 2-hour fire-resistant-rated perimeter.

**14.2.1.1.4** When trailer or vehicle-mounted facilities are located contiguous to a health care facility or another structure,

a 2-hour fire-resistant-rated barrier shall be placed between the facility and the contiguous structure.

**14.2.1.1.5** Where building exterior walls form part of the facility boundary, that portion of the facility boundary shall not require 2-hour fire-resistant-rated construction.

**14.2.1.1.6\*** If there are connecting doors through such common walls of contiguity, they shall be at least B-label, 1½-hour fire doors.

**14.2.1.1.7** When used for hyperbaric procedures, the room or rooms housing the Class A or Class B chambers shall be for the exclusive use of the hyperbaric operation.

**14.2.1.1.8** Service equipment (e.g., compressors) shall be permitted to be located in multi-use spaces meeting the requirements of 14.2.1.1.

**14.2.1.1.9** The supporting foundation for any chamber shall be designed to support the chamber.

**14.2.1.1.9.1** If on-site hydrostatic testing will be performed, the chamber supporting foundation shall be designed to support an additional water weight.

**14.2.1.2\*** A hydraulically calculated automatic wet pipe sprinkler system meeting the requirements of NFPA 13, *Standard for the Installation of Sprinkler Systems*, shall be installed in the room housing a Class A, Class B, or Class C chamber and in any ancillary equipment rooms.

**14.2.1.2.1** Class A, Class B, or Class C chambers not contiguous to a health care facility and located in a mobile vehicle-mounted facility shall not be required to be protected as specified in 14.2.1.2.

**14.2.1.2.2\*** Chamber room sprinkler heads shall be an approved type equipped with fusible elements.

**14.2.1.2.3** The element temperature ratings shall be as low as possible, consistent with the requirements against false operation in NFPA 13.

#### 14.2.1.3 Hyperbaric Piping Requirements.

**14.2.1.3.1\*** Except where otherwise required by this chapter, piping systems dedicated to the hyperbaric chamber shall meet the requirements of ANSI/ASME PVHO-1, *Safety Standard for Pressure Vessels for Human Occupancy*, for hyperbaric facility piping systems.

**14.2.1.3.2** Shutoff valves accessible to facility personnel shall be provided for piping specified in 14.2.1.3.1 at the point of entry to the room housing the chamber(s).

#### 14.2.1.4 Hyperbaric Medical Oxygen System Requirements.

**14.2.1.4.1** Where medical oxygen systems are installed for hyperbaric use, the hyperbaric area(s) or facility shall be treated as a separate zone.

**14.2.1.4.2** The requirements of Chapter 5 shall apply to the medical oxygen system for hyperbaric use, from the source of supply to the first in-line valve located downstream of the zone valve(s).

**14.2.1.4.3** The requirements of ANSI/ASME PVHO-1, *Safety Standard for Pressure Vessels for Human Occupancy*, shall apply to the medical oxygen system for hyperbaric use, starting immediately downstream of the first in-line valve located after the zone valve(s).

**14.2.1.4.4 General.** Where an oxygen system is installed for hyperbaric treatments, it shall comply with the requirements for the appropriate level as determined in 14.2.1.4.4.2 through 14.2.1.5.

**14.2.1.4.4.1** Hyperbaric oxygen systems for acute and non-acute care connected directly to a hospital's oxygen system shall comply with Section 5.1, as applicable, except as noted in 14.2.1.4.4.2.

**14.2.1.4.4.2 Central Supply Systems.** Oxygen systems shall comply with 5.1.3.5, as applicable, except as follows:

- (1) An emergency oxygen supply connection (EOSC) is not required for the hyperbaric oxygen system.
- (2) An in-building emergency reserve (IBER) is not required for the hyperbaric oxygen system.

**14.2.1.4.4.3** Hyperbaric stand-alone oxygen systems for acute care shall comply with Section 5.1, as applicable, except as noted in 14.2.1.4.4.4.

**14.2.1.4.4.4 Central Supply Systems.** Oxygen systems shall comply with 5.1.3.5, as applicable, except as follows:

- (1) An EOSC is not required for the hyperbaric oxygen system.
- (2) An IBER is not required for the hyperbaric oxygen system.

**14.2.1.4.4.5 Warning Systems.** Oxygen systems shall comply with 5.1.9, as applicable, except that warning systems shall be permitted to be a single master/area alarm panel.

**14.2.1.4.4.6** Hyperbaric stand-alone oxygen systems for non-acute care shall comply with Section 5.2, as applicable, except as noted in 14.2.1.4.4.7.

**14.2.1.4.4.7 Central Supply Systems.** Oxygen systems shall comply with 5.1.3.5, as applicable, except as follows:

- (1) If the operating oxygen supply consists of high pressure cylinders designed with a primary and secondary source, no reserve supply is required.
- (2) If the operating oxygen supply consists of liquid containers designed with a primary and secondary source, a reserve with a minimum supply of 15 minutes is required.
- (3) If the operating oxygen supply consists of a bulk primary, a reserve with a minimum supply of 15 minutes is required.
- (4) An EOSC is not required for the hyperbaric oxygen system.
- (5) An IBER is not required for the hyperbaric oxygen system.

**14.2.1.5 Storage and Handling of Medical Gases.** Storage and handling of medical gases shall meet the applicable requirements of Chapter 5.

#### **14.2.1.6 Hyperbaric Medical Air System Requirements.**

**14.2.1.6.1** Where medical air systems are installed for hyperbaric use, the hyperbaric area(s) or facility shall be treated as a separate zone.

**14.2.1.6.2** Chapter 5 requirements shall apply to the medical air system for hyperbaric use, from the source of supply to the first in-line valve located downstream of the zone valve(s).

**14.2.1.6.3** ANSI/ASME PVHO-1, *Safety Standard for Pressure Vessels for Human Occupancy*, requirements shall apply to the medical air system for hyperbaric use, starting immediately downstream of the first in-line valve located after the zone valve(s).

**14.2.1.6.4** Where a medical air system is installed for hyperbaric treatments, it shall comply with the requirements for the appropriate level as determined in 14.2.1.6.4.1 through 14.2.1.6.4.7.

**14.2.1.6.4.1** Hyperbaric medical air systems for acute and non-acute care connected directly to a hospital's medical air system shall comply with Section 5.2, as applicable.

**14.2.1.6.4.2 Reserved.**

**14.2.1.6.4.3** Hyperbaric stand-alone medical air systems for acute care shall comply with Section 5.2, as applicable.

**14.2.1.6.4.4 Reserved.**

**14.2.1.6.4.5** Medical air systems for acute care shall comply with Section 5.2, as applicable, except that warning systems shall be permitted to be a single master/area alarm panel.

**14.2.1.6.4.6** Hyperbaric stand-alone medical systems for non-acute care shall comply with Section 5.2, as applicable, except as noted in 14.2.1.6.4.7.

**14.2.1.6.4.7** Medical air systems shall comply with Section 5.2 as applicable, except as follows:

- (1) Area and master alarms are not required for non-acute care.
- (2) A gas cylinder header per Section 5.2 with sufficient cylinder connections to provide for at least an average day's supply with the appropriate number of connections being determined after consideration of delivery schedule, proximity of the facility to alternate supplies, and the facility's emergency plan are permitted.

#### **14.2.2 Fabrication of the Hyperbaric Chamber.**

**14.2.2.1\*** Chambers for human occupancy and their supporting systems shall be designed and fabricated to meet ANSI/ASME PVHO-1, *Safety Standard for Pressure Vessels for Human Occupancy*, by personnel qualified to fabricate vessels under such codes.

**14.2.2.1.1** Piping systems for hyperbaric facilities shall be required to meet only the requirements of this chapter and section "Piping" of ANSI/ASME PVHO-1, *Safety Standard for Pressure Vessels for Human Occupancy*.

**14.2.2.1.2** Piping that is installed in concealed locations in the building housing the hyperbaric facility, such as inside building walls or above false ceilings, shall use only those joining procedures permitted by Chapter 5.

**14.2.2.2** The chamber shall be stamped in accordance with ANSI/ASME PVHO-1, *Safety Standard for Pressure Vessels for Human Occupancy*.

**14.2.2.3** As a minimum, animal chambers shall be designed, fabricated, and stamped to meet ASME *Boiler and Pressure Vessel Code* Section VIII, Division 1 code requirements.

**14.2.2.4** The floor of a Class A chamber shall be designed to support equipment and personnel necessary for the operation of the chamber according to its expected purpose.

**14.2.2.4.1** The floor of Class A chambers shall be noncombustible.

**14.2.2.4.2** If the procedures to be carried out in the Class A hyperbaric chamber require antistatic flooring, the flooring shall be installed in accordance with the provisions of 13.3.1.

**14.2.2.4.3** If a bilge is installed, access to the bilge shall be provided for cleaning purposes.

**14.2.2.4.4** If the interior floor of a Class A chamber consists of removable floor (deck) plates, the plates shall be mechanically secured and electrically bonded to the chamber to ensure a positive electrical ground and to prevent movement of the plate, which could cause injury to personnel.

**14.2.2.5\*** The interior of Class A chambers shall be unfinished or treated with a finish that is one of the following:

- (1) High quality epoxy
- (2) Noncombustible material as defined in 3.3.123

**14.2.2.5.1** If the interior of a Class A chamber is treated (painted) with a finish listed in 14.2.2.5, the cure procedure and minimum duration for each coat of finish to off-gas shall be in accordance with the manufacturer's application instructions and material safety data sheets.

**14.2.2.5.2\*** If sound-deadening materials are employed within a hyperbaric chamber, they shall be limited-combustible materials as defined in 3.3.98.

**14.2.2.6\*** Viewing ports, access ports for piping and wiring or monitoring, and related leads shall be installed during initial fabrication of the chamber.

**14.2.2.6.1** Access ports in Class A chambers, access ports for monitoring, and other electrical circuits shall be housed in enclosures that are weatherproof, both inside and outside the chamber, for protection in the event of sprinkler activation.

**14.2.2.6.2** Viewports and penetrator plates shall be designed and fabricated according to ANSI/ASME PVHO-1, *Safety Standard for Pressure Vessels for Human Occupancy*.

### **14.2.3 Illumination.**

**14.2.3.1** Unless designed for chamber use, sources of illumination shall be mounted outside the pressure chamber and arranged to shine through chamber ports or through chamber penetrators designed for fiberoptic or similar lighting.

**14.2.3.1.1** Lighting fixtures used in conjunction with viewports shall be designed so that temperature ratings for the viewport material given in ANSI/ASME PVHO-1 are not exceeded.

**14.2.3.1.2** Gasket material shall be of a type that allows the movement of thermal expansion and shall be selected for the temperatures, pressures, and composition of gases involved.

**14.2.3.1.2.1** Gaskets or O-rings shall be confined to grooves or enclosures, which will prevent their being blown out or squeezed from the enclosures or compression flanges.

**14.2.3.2** Lighting permanently installed inside the chamber and portable lighting for temporary use inside the chamber shall meet the requirements of 14.2.7.3.15.

**14.2.3.3** Emergency lighting for the interior of the chamber shall be provided.

### **14.2.4 Chamber Ventilation.**

#### **14.2.4.1 Ventilation of Class A Chambers.**

**14.2.4.1.1** The minimum ventilation rate for a Class A chamber shall be 0.085 m<sup>3</sup>/min (3 ft<sup>3</sup>/min) of air per chamber occupant who is not using a breathing-mask overboard dump system that exhausts exhaled gases.

**14.2.4.1.1.1** The minimum threshold rate shall be 0.085 m<sup>3</sup>/min (3 ft<sup>3</sup>/min).

**14.2.4.1.1.2** Provision shall be made for ventilation during nonpressurization of Class A chambers as well as during pressurization.

**14.2.4.1.2\*** Ventilation shall not be required when saturation operations are conducted in the chamber, provided that carbon dioxide removal and odor control are accomplished and that the monitoring requirements of 14.2.8.4.1 and 14.2.8.5 are met.

**14.2.4.1.3** Individual breathing apparatus shall be available inside a Class A chamber for each occupant for use in the event that the chamber atmosphere is fouled by combustion or otherwise.

**14.2.4.1.3.1** The breathing mixture supplied to breathing apparatus shall be independent of chamber atmosphere.

**14.2.4.1.3.2** The breathing gas supply shall be designed for simultaneous use of all breathing apparatus.

**14.2.4.1.3.3** Breathing apparatus shall function at all pressures that can be encountered in the chamber.

**14.2.4.1.3.4** In the event of a fire within a chamber, provision shall be made to switch all breathing apparatus to an air supply that is independent of the chamber atmosphere.

#### **14.2.4.2 Sources of Air for Chamber Atmospheres.**

**14.2.4.2.1\*** Sources of air for chamber atmospheres shall be such that toxic or flammable gases are not introduced.

**14.2.4.2.2** Compressor intakes shall be located away from air contaminated by exhaust from activities of vehicles, internal combustion engines, stationary engines, or building exhaust outlets.

**14.2.4.2.3** Air supply for chamber atmosphere shall be monitored as required in 14.2.8.6.

**14.2.4.2.4** The use of conventional oil-lubricated compressors shall be permitted, provided that they are fitted with air treatment packages designed to produce medical air and they meet the monitoring requirements of 14.2.8.6.

**14.2.4.2.4.1** The air treatment packages shall include automatic safeguards.

**14.2.4.2.5** Air compressor installations shall consist of two or more individual compressors with capacities such that required system flow rates can be maintained on a continuous basis with any single compressor out of operation, unless 14.2.7.2.5 is satisfied.

**14.2.4.2.5.1** Each compressor shall be supplied from separate electrical branch circuits.

**14.2.4.2.6** Air compressor installations that supply medical air to piped gas systems as well as to hyperbaric facilities shall meet the requirements of 5.1.3.6.3 and this chapter.

**14.2.4.2.7** Air compressor installations that are used exclusively for hyperbaric facilities shall meet the requirements of this chapter only.

#### **14.2.4.3 Temperature and Humidity Control.**

**14.2.4.3.1** Warming or cooling of the atmosphere within a Class A chamber shall be permitted by circulating the ambient air within the chamber over or past coils through which a constant flow of warm or cool water or water/glycol mixture is circulated.

**14.2.4.3.2\*** Class A chambers that are not used in the capacity of an operating room shall maintain a temperature that is comfortable for the occupants [usually 22°C ±2°C (75°F ±5°F)].

**14.2.4.3.3** Whenever the Class A chamber is used as an operating room, it shall be ventilated, and the air supply thereto shall be conditioned according to the minimum requirements for temperature for hospital operating rooms as specified in 13.3.1.

**14.2.4.3.3.1** If inhalation anesthetic agents are being utilized (e.g., halothane, isoflurane, sevoflurane, desflurane), a closed anesthetic system with exhaled gas scavenging and overboard dumping shall be employed.

**14.2.4.3.3.2** Flammable inhalation anesthetics (e.g., cyclopropane, ethyl ether, ethylene, and ethyl chloride) shall not be employed.

**14.2.4.3.4** Dehumidification shall be permitted through the use of cold coils.

**14.2.4.3.5** Humidification by the use of an air-powered water nebulizer shall be permitted.

**14.2.4.3.6** Noncombustible packing and nonflammable lubricant shall be employed on the fan shaft.

**14.2.4.4 Ventilation of Class B Chambers.**

**14.2.4.4.1\*** The minimum ventilation rate for a Class B chamber shall be 0.0283 m<sup>3</sup>/min (1 ft<sup>3</sup>/min).

**14.2.4.4.2** Class B chambers not designed for 100 percent oxygen environment shall comply with the monitoring requirements of 14.2.8.4.

**14.2.4.4.3** For Class B chambers equipped with a breathing apparatus, the breathing apparatus shall function at all pressures that can be encountered in the chamber.

**14.2.4.5 Emergency Depressurization and Facility Evacuation Capability.**

**14.2.4.5.1** Class A chambers shall be capable of depressurizing from 3 ATA (304.0 kPa) to ambient pressure in not more than 6 minutes.

**14.2.4.5.2** Class B chambers shall be capable of depressurizing from 3 ATA (304.0 kPa) to ambient pressure in not more than 2 minutes.

**14.2.4.5.3\*** A source of breathable gas allowing unrestricted mobility shall be available outside a Class A or Class B chamber for use by personnel in the event that the air in the vicinity of the chamber is fouled by smoke or other combustion products of fire.

**14.2.4.5.4** The time required to evacuate all persons from a hyperbaric area with a full complement of chamber occupants all at treatment pressure shall be measured annually during the fire training drill required by 14.3.1.4.5.

**14.2.4.5.4.1** The occupants for this training drill shall be permitted to be simulated.

**14.2.5 Fire Protection in Class A Chambers.**

**14.2.5.1 General.**

**14.2.5.1.1** A fire suppression system consisting of independently supplied and operating handline- and deluge-type water spray systems shall be installed in all Class A chambers.

**14.2.5.1.2** Design of the fire suppression system shall be such that failure of components in either the handline or deluge system will not render the other system inoperative.

**14.2.5.1.3** System design shall be such that activation of either the handline or the deluge system shall automatically cause the following:

- (1) Visual and aural indication of activation shall occur at the chamber operator's console.

- (2) All ungrounded electrical leads for power and lighting circuits contained inside the chamber shall be disconnected.
- (3) Emergency lighting (*see 14.2.3.3*) and communication, where used, shall be activated.

**14.2.5.1.3.1** Intrinsically safe circuits, including sound-powered communications, shall be permitted to remain connected when either the handline or the deluge system is activated.

**14.2.5.1.4\*** A fire alarm signaling device shall be provided at the chamber operator's control console for signaling the emergency fire/rescue network of the institution containing the hyperbaric facility.

**14.2.5.1.4.1** Trailer or vehicle-mounted facilities not contiguous to a health care facility shall conform to one of the following:

- (1) They shall comply with 14.2.5.1.4.
- (2) They shall have a means for immediately contacting the local fire department.

**14.2.5.1.5\*** Fire blankets and portable carbon dioxide extinguishers shall not be installed in or carried into the chamber.

**14.2.5.1.6** Booster pumps, control circuitry, and other electrical equipment involved in fire suppression system operation shall be powered from a critical branch of the emergency electrical system as specified in 14.2.7.2.2.2.

**14.2.5.1.7** Signs prohibiting the introduction of flammable liquids, gases, and other articles not permitted by this chapter into the chamber shall be posted at the chamber entrance(s).

**14.2.5.1.8** The fire suppression system shall be permitted to be supplied from the local potable water service.

**14.2.5.2 Deluge System.** A fixed water deluge extinguishing system shall be installed in all chamber compartments that are designed for manned operations.

**14.2.5.2.1** In chambers that consist of more than one chamber compartment (lock), the design of the deluge system shall meet the requirements of 14.2.5.2 when the chamber compartments are at different depths (pressures).

**14.2.5.2.2** The deluge system in different compartments (locks) shall operate independently or simultaneously.

**14.2.5.2.3** Fixed deluge systems shall not be required in chamber compartments that are used strictly as personnel transfer compartments (locks) and for no other purposes.

**14.2.5.2.4\*** Manual activation and deactivation deluge controls shall be located at the operator's console and in each chamber compartment (lock) containing a deluge system.

**14.2.5.2.4.1** Controls shall be designed to prevent unintended activation.

**14.2.5.2.5** Water shall be delivered from the fixed discharge nozzles as specified in 14.2.5.2.7 within 3 seconds of activation of any affiliated deluge control.

**14.2.5.2.6\*** Average spray density at floor level shall be not less than 81.5 L/min/m<sup>2</sup> (2 gpm/ft<sup>2</sup>), with no floor area larger than 1 m<sup>2</sup> (10.76 ft<sup>2</sup>) receiving less than 40.75 L/min/m<sup>2</sup> (1 gpm/ft<sup>2</sup>).

**14.2.5.2.7** Water shall be available in the deluge system to maintain the flow specified in 14.2.5.2.6 simultaneously in each chamber compartment (lock) containing the deluge system for 1 minute.

**14.2.5.2.7.1** The limit on maximum extinguishment duration shall be governed by the chamber capacity (bilge capacity also, if so equipped) or its drainage system, or both.

**14.2.5.2.8** The deluge system shall have stored pressure to operate for at least 15 seconds without electrical branch power.

**14.2.5.3 Handline System.** A handline extinguishing system shall be installed in all chamber compartments (locks).

**14.2.5.3.1** At least two handlines shall be strategically located in treatment compartments (locks).

**14.2.5.3.2** At least one handline shall be located in each personnel transfer compartment (lock).

**14.2.5.3.3** If any chamber compartment (lock) is equipped with a bilge access panel, at least one handline shall reach the bilge area.

**14.2.5.3.4** Handlines shall have a 12.7 mm (0.5 in.) minimum internal diameter and shall have a rated working pressure greater than the highest supply pressure of the supply system.

**14.2.5.3.5** Each handline shall be activated by a manual, quick-opening, quarter-turn valve located within the compartment (lock).

**14.2.5.3.5.1** A hand-operated spring-return to close valves at the discharge end of handlines shall be permitted.

**14.2.5.3.6** Handlines shall be equipped with override valves that are accessible to personnel outside the chamber.

**14.2.5.3.7** The water supply for the handline system shall be designed to ensure a 345 kPa (50 psi) minimum water pressure above the maximum chamber pressure.

**14.2.5.3.7.1** The system shall be capable of supplying a minimum of 18.9 L/min (5 gpm) simultaneously to each of any two of the handlines at the maximum chamber pressure for a period of not less than 4 minutes.

**14.2.5.4 Automatic Detection System.** Automatic fire detection systems shall not be required.

**14.2.5.4.1** Surveillance fire detectors responsive to the radiation from flame shall be employed.

**14.2.5.4.1.1** The type and arrangement of detectors shall be such as to respond within 1 second of flame origination.

**14.2.5.4.2\*** The number of detectors employed and their location shall be selected to cover the chamber interior.

**14.2.5.4.3** The system shall be powered from the critical branch of the emergency electrical system or shall have automatic battery backup.

**14.2.5.4.4** If used to automatically activate the deluge system, the requirements for manual activation/deactivation in 14.2.5.2.4 and deluge system response time in 14.2.5.2.5 shall still apply.

**14.2.5.4.5** The system shall include self-monitoring functions for fault detection and fault alarms and indications.

**14.2.5.4.6** Automatic fire detection equipment, when used, shall meet the applicable requirements in 14.2.7.3.

**14.2.5.5\* Testing.** The deluge and handline systems shall be functionally tested at least semiannually per 14.2.5.2.7 for deluge systems and 14.2.5.3.7 for handline systems.

**14.2.5.5.1** Following the test, all valves shall be placed in their baseline position.

**14.2.5.5.2** If a bypass system is used, it shall not remain in the test mode after completion of the test.

**14.2.5.5.3** During initial construction, or whenever changes are made to the installed deluge system that will affect the spray pattern, testing of spray coverage to demonstrate conformance to the requirements of 14.2.5.2.6 shall be performed at surface pressure and at maximum operating pressure.

**14.2.5.5.3.1** The requirements of 14.2.5.2.6 shall be satisfied under both surface pressure and maximum operating pressure.

**14.2.5.5.4** A detailed record of the test results shall be maintained and a copy sent to the hyperbaric facility safety director.

**14.2.6 Fire Protection in Class B and Class C Chambers.** Class B and Class C chambers shall not be required to comply with 14.2.5.

**14.2.6.1** Signs prohibiting the introduction of flammable liquids, gases, and other articles not permitted by this chapter into the chamber shall be posted at the chamber entrance(s).

**14.2.6.2** A fire alarm signaling device shall be provided within the room housing the chamber(s) for signaling the emergency fire/rescue network of the institution containing the hyperbaric facility.

**14.2.6.2.1** Trailer or vehicle-mounted facilities not contiguous to a health care facility shall conform to one of the following:

- (1) They shall comply with 14.2.6.2.
- (2) They shall have a means for immediately contacting the local fire department.

**14.2.7 Electrical Systems.**

**14.2.7.1 General.**

**14.2.7.1.1** The requirements of *NFPA 70, National Electrical Code*, or local electrical codes shall apply to electrical wiring and equipment in hyperbaric facilities within the scope of this chapter, except as such rules are modified in 14.2.7.

**14.2.7.1.2** All hyperbaric chamber service equipment, switchboards, panels, or control consoles shall be located outside of, and in the vicinity of, the chamber.

**14.2.7.1.3** Console or module spaces containing both oxygen piping and electrical equipment shall be either one of the following:

- (1) Mechanically or naturally ventilated
- (2) Continuously monitored for excessive oxygen concentrations whenever the electrical equipment is energized

**14.2.7.1.4** For the fixed electrical installation, none of the following shall be permitted inside the chamber:

- (1) Circuit breakers
- (2) Line fuses
- (3) Motor controllers
- (4) Relays
- (5) Transformers
- (6) Ballasts
- (7) Lighting panels
- (8) Power panels

**14.2.7.1.4.1\*** If motors are to be located in the chamber, they shall meet the requirements of 14.2.7.3.14.

**14.2.7.1.5** All electrical equipment connected to, or used in conjunction with, hyperbaric patients shall comply with the requirements of Chapter 10 and with the applicable subparagraphs of 14.2.7.3.

**14.2.7.1.6** In the event of activation of the room sprinkler system, electrical equipment shall be protected from sprinkler water but shall not be required to remain functional if manual means to control and decompress the chamber are provided.

**14.2.7.2 Electrical Service.**

**14.2.7.2.1** All hyperbaric facilities shall contain an electrical service that is supplied from two independent sources of electric power.

**14.2.7.2.1.1** All hyperbaric facilities for human occupancies shall contain an electrical service that is supplied from two independent sources of electric power.

**14.2.7.2.1.2** For hyperbaric facilities using a prime-mover-driven generator set, it shall be designated as the life safety and critical branches and shall meet the requirements of Chapter 6 for hyperbaric systems based in health care facilities.

**14.2.7.2.1.3** Article 700 of *NFPA 70, National Electrical Code*, shall apply to hyperbaric systems located in facilities other than health care facilities.

**14.2.7.2.2** Electrical equipment associated with life-support functions of hyperbaric facilities shall be connected to the critical branch of the life safety and critical branches, which requires that such equipment shall have electrical power restored within 10 seconds of interruption of normal power.

**14.2.7.2.2.1** The equipment specified in 14.2.7.2.2 shall include, but is not limited to, the following:

- (1) Electrical power outlets located within the chamber
- (2) Chamber emergency lighting, whether internally or externally mounted
- (3) Chamber intercommunications
- (4) Alarm systems, including fire detectors
- (5) Chamber fire suppression system equipment and controls
- (6) Other electrical controls used for chamber pressurization and ventilation control
- (7) A sufficient number of chamber room lights (either overhead or local) to ensure continued safe operation of the facility during a normal power outage

**14.2.7.2.2.2** Booster pumps in the chamber fire suppression system shall be on separate branch circuits serving no other loads.

**14.2.7.2.3** Electric motor-driven compressors and auxiliary electrical equipment normally located outside the chamber and used for chamber atmospheric control shall be connected to the equipment system (see Chapter 6) or the life safety and critical branches (see *NFPA 70, National Electrical Code, Article 700*), as applicable.

**14.2.7.2.4** Electric motor-driven compressors and auxiliary electrical equipment shall be arranged for delayed-automatic or manual connection to the alternate power source so as to prevent excessive current draw on the system during restarting.

**14.2.7.2.5** When reserve air tanks or a nonelectric compressor(s) is provided to maintain ventilation airflow within the chamber and supply air for chamber pressurization, the compressor(s) and auxiliary equipment shall not be required to have an alternate source of power.

**14.2.7.2.6** Electrical control and alarm system design shall be such that hazardous conditions (e.g., loss of chamber pressure control, deluge activation, spurious alarms) do not occur during power interruption or during power restoration.

**14.2.7.3\* Wiring and Equipment Inside Class A Chambers.** The general rules of 14.2.7.3.1 through 14.2.7.3.17.6 shall be satisfied in the use of electrical devices and equipment. These requirements are intended to protect against the elevated fire risks known to exist in a pressurized air environment and shall not be construed as classifying the chamber interior as a Class I (as defined in *NFPA 70, National Electrical Code, Article 500*) hazardous location.

**14.2.7.3.1** Equipment or equipment components installed in, or used in, the chamber shall not present an explosion or implosion hazard under the conditions of hyperbaric use.

**14.2.7.3.2** All equipment shall be rated, or tested and documented, for intended hyperbaric conditions prior to use.

**14.2.7.3.3** Only the electrical equipment necessary for the safe operation of the chamber and for required patient care shall be permitted in the chamber.

**14.2.7.3.4** Only portable equipment necessary for the logistical and operational support shall be permitted in the chamber during manned pressurization.

**14.2.7.3.5** Where conformance with Class I, Division 1 requirements is specified in 14.2.7.3.7, conformance with Class I, Division 2 requirements shall be permitted to be substituted.

**14.2.7.3.6 Wires and Cables.** Wires and cables used inside the chamber shall be resistant to the spread of fire by complying with 14.2.7.3.6.1 or shall be contained within equipment described in 14.2.7.3.6.2.

**14.2.7.3.6.1** Wires and cables shall comply with the spread of fire requirements of “UL Flame Exposure, Vertical Tray Flame Test” in UL 1685, *Standard for Vertical-Tray Fire-Propagation and Smoke-Release Test for Electrical and Optical-Fiber Cables*, or shall exhibit damage (char length) not to exceed 1.5 m (4 ft 11 in.) when performing the CSA “Vertical Flame Test — Cables in Cable Trays,” as described in CSAC22.2 No. 0.3-M, *Test Methods for Electrical Wires and Cables*.

**14.2.7.3.6.2** Wires and cables that form an integral part of electrical equipment approved or listed specifically for use inside hyperbaric chambers, including patient leads, shall not be required to comply with the requirements of 14.2.7.3.6.1.

**14.2.7.3.7 Wiring Methods.**

**14.2.7.3.7.1** Fixed wiring shall be installed in threaded RMC or IMC conduit utilizing the following waterproof components:

- (1) Threaded metal joints
- (2) Fittings
- (3) Boxes
- (4) Enclosures

**14.2.7.3.7.2** A continuous ground shall be maintained between all conductive surfaces enclosing electrical circuits and the chamber hull using approved grounding means.

**14.2.7.3.7.3** All threaded conduit shall be threaded with an NPT standard conduit cutting die that provides a 19 mm taper per 0.3 m (0.75 in. taper per 1 ft).

**14.2.7.3.7.4** All threaded conduit shall be made wrench-tight to prevent sparking when fault current flows through the conduit system.

**14.2.7.3.7.5** Wiring classified as intrinsically safe for any group location and installed in accordance with Article 504 of *NFPA 70, National Electrical Code*, shall be permitted.

**14.2.7.3.7.6** Threaded, liquidtight flexible metal conduit installed in accordance with Article 351 of *NFPA 70, National Electrical Code*, shall be permitted when protected from damage by physical barriers such as equipment panels.

**14.2.7.3.8 Drainage.** Means of draining fixed conduit and fixed equipment enclosures shall be provided.

**14.2.7.3.9 Flexible Electrical Cords.** Flexible cords used to connect portable utilization equipment to the fixed electrical supply circuit shall meet all of the following requirements:

- (1) They shall be of a type approved for extra-hard utilization in accordance with Table 400.4 of *NFPA 70, National Electrical Code*.
- (2) They shall include a ground conductor.
- (3) They shall meet the requirements of 501.11 of *NFPA 70, National Electrical Code*.

**14.2.7.3.9.1** The normal cord supplied with the portable utilization equipment shall be permitted when the portable device is rated at less than 2 A and the cord is positioned out of traffic and protected from physical abuse.

**14.2.7.3.10\* Receptacles Installed Inside the Chamber.**

**14.2.7.3.10.1** Receptacles shall be waterproof.

**14.2.7.3.10.2** Receptacles shall be of the type providing for connection to the grounding conductor of the flexible cord.

**14.2.7.3.10.3** Receptacles shall be supplied from isolated power circuits meeting the requirements of 14.2.7.4.2.

**14.2.7.3.10.4** The design of the receptacle shall be such that sparks cannot be discharged into the chamber environment when the plug is inserted or withdrawn under electrical load.

**14.2.7.3.10.5** One of the following shall be satisfied to protect against inadvertent withdrawal of the plug under electrical load:

- (1) The receptacle–plug combination shall be of a locking type.
- (2) The receptacle shall carry a label warning against unplugging under load, and the power cord shall not present a trip hazard for personnel moving in the chamber.

**14.2.7.3.11 Switches.** Switches in the fixed wiring installation shall be waterproof.

**14.2.7.3.11.1\*** Switch make and break contacts shall be housed in the electrical enclosure so that no sparks from arcing contacts can reach the chamber environment.

**14.2.7.3.12\* Temperature.** No electrical equipment installed or used in the chamber shall have an operating surface temperature in excess of 85°C (185°F).

**14.2.7.3.13 Exposed Live Electrical Parts.** No exposed live electrical parts shall be permitted, except as specified in 14.2.7.3.13.1 and 14.2.7.3.13.2.

**14.2.7.3.13.1** Exposed live electrical parts that are intrinsically safe shall be permitted.

**14.2.7.3.13.2** Exposed live electrical parts that constitute patient monitoring leads, which are part of electromedical equipment, shall be permitted, provided that they meet the requirements of 14.2.7.3.17.

**14.2.7.3.14 Motors.** Motors shall meet one of the following requirements:

- (1) They shall comply with 501.8(A)(1) of *NFPA 70, National Electrical Code*, for the chamber pressure and oxygen concentration.
- (2) They shall be of the totally enclosed types meeting 501.8(A)(2) or 501.8(A)(3) of *NFPA 70, National Electrical Code*.

**14.2.7.3.15\* Lighting.**

**14.2.7.3.15.1** Lighting installed or used inside the chamber shall be rated for a pressure of 1½ times the chamber working pressure.

**14.2.7.3.15.2** Permanently installed fixtures shall meet the following requirements:

- (1) They shall be rated and approved for Class I (Division 1 or 2) classified areas.
- (2) They shall have lens guards installed.
- (3) They shall be located away from areas where they would experience physical damage from the normal movement of people and equipment.

**14.2.7.3.15.3** Ballasts and other energy storage components that are part of the lighting circuit shall be installed outside the chamber in accordance with 14.2.7.1.4.

**14.2.7.3.15.4** Portable fixtures intended for spot illumination shall be shatterproof or protected from physical damage.

**14.2.7.3.16 Low-Voltage, Low-Power Equipment.** The requirements of 14.2.7.3.16.1 through 14.2.7.3.16.5 shall apply to sensors and signaling, alarm, communications, and remote-control equipment installed or used in the chamber for operation of the chamber.

**14.2.7.3.16.1\*** Equipment shall be isolated from main power by one of the following means:

- (1) Design of the power supply circuit
- (2) Opto-isolation
- (3) Other electronic isolation means

**14.2.7.3.16.2** Circuits such as headset cables, sensor leads, and so forth, not enclosed as required in 14.2.7.3.7, shall meet one of the following requirements:

- (1) They shall be part of approved intrinsically safe equipment.
- (2) They shall be limited by circuit design to not more than 28 V and 0.5 A under normal or circuit-fault conditions.

**14.2.7.3.16.3** Chamber speakers shall be of a design in which the electrical circuitry and wiring is completely enclosed.

**14.2.7.3.16.4** The electrical rating of chamber speakers shall not exceed 28 V rms and 25 W.

**14.2.7.3.16.5** Battery-operated, portable intercom headset units shall meet the requirements of 14.2.7.3.17.5 for battery-operated devices.

**14.2.7.3.17\* Portable Patient Care–Related Electrical Appliances.**

**14.2.7.3.17.1** The appliance shall be designed and constructed in accordance with Chapter 10.

**14.2.7.3.17.2** The electrical and mechanical integrity of the appliance shall be verified and documented through an ongoing maintenance program as required in Chapter 10.



**14.2.7.3.17.3** The appliance shall conform to the requirements of 14.2.7.3.1 and 14.2.7.3.12.

**14.2.7.3.17.4** Appliances that utilize oxygen shall not allow oxygen accumulation in the electrical portions of the equipment under normal and abnormal conditions.

**14.2.7.3.17.5 Battery-Operated Devices.** Battery-operated devices shall meet the following requirements:

- (1) Batteries shall be fully enclosed and secured within the equipment enclosure.
- (2) Batteries shall not be damaged by the maximum chamber pressure to which they are exposed.
- (3) Batteries shall be of a sealed type that does not off-gas during normal use.
- (4) Batteries or battery-operated equipment shall not undergo charging while located in the chamber.
- (5) Batteries shall not be changed on in-chamber equipment while the chamber is in use.
- (6) The equipment electrical rating shall not exceed 12 V and 48 W.
- (7) Lithium and lithium ion batteries shall be prohibited in the chamber during chamber operations, unless the product has been accepted or listed for use in hyperbaric conditions by the manufacturer or a nationally recognized testing agency.

**14.2.7.3.17.6 Cord-Connected Devices.** Cord-connected devices shall meet the following requirements:

- (1) All portable, cord-connected equipment shall have an on/off power switch.
- (2) The equipment electrical rating shall not exceed 120 V and 2 A, unless the electrical portions of the equipment are inert-gas purged.
- (3) The plug of cord-connected devices shall not be used to interrupt power to the device.

**14.2.7.4 Grounding and Ground-Fault Protection.**

**14.2.7.4.1** All chamber hulls shall be grounded to an electrical ground or grounding system that meets the requirements of Article 250, Grounding and Bonding, Section III, Grounding Electrode System and Grounding Electrode Conductor, of *NFPA 70, National Electrical Code*.

**14.2.7.4.1.1** Grounding conductors shall be secured as required by Article 250, Grounding and Bonding, Section III, Grounding Electrode System and Grounding Electrode Conductor, of *NFPA 70, National Electrical Code*.

**14.2.7.4.1.2** The material, size, and installation of the grounding conductor shall meet the requirements of Article 250, Grounding and Bonding, Section VI, Equipment Grounding and Equipment Grounding Conductors, of *NFPA 70, National Electrical Code*, for equipment grounding conductors.

**14.2.7.4.1.3** The resistance between the grounded chamber hull and the electrical ground shall not exceed 1 ohm.

**14.2.7.4.2** In health care facilities, electrical power circuits located within the chamber shall be supplied from an ungrounded electrical system equipped with a line isolation monitor with signal lamps and audible alarms.

**14.2.7.4.2.1** The circuits specified in 14.2.7.4.2 shall meet the requirements of 517.160 and 517.160(B) of *NFPA 70, National Electrical Code*.

**14.2.7.4.2.2** Branch circuits shall not exceed 125 V or 15 A.

**14.2.7.4.3** Wiring located both inside and outside the chamber, that serves line level circuits and equipment located inside the chamber, shall meet the grounding and bonding requirements of 501.16 of *NFPA 70, National Electrical Code*.

**14.2.7.5 Wiring Outside the Chamber.** Those electrical components that must remain functional for the safe termination of a dive following activation of the room sprinkler system shall be enclosed in waterproof housing.

**14.2.7.5.1** All associated conduits shall meet the following requirements:

- (1) They shall be waterproof.
- (2) They shall meet the requirements of *NFPA 70, National Electrical Code*.
- (3) They shall be equipped with approved drains.

**14.2.7.5.2\*** All other electrical devices outside the chamber shall meet the requirements of *NFPA 70*.

**14.2.7.6 Additional Wiring and Equipment Requirements Inside Class B Chambers.** The requirements in 14.2.7.6 shall apply to Class B chambers whether they are pressurized with oxygen or with air.

**14.2.7.6.1** Electrical equipment inside Class B chambers shall be restricted to communications functions and patient physiological monitoring leads.

**14.2.7.6.1.1\*** Each circuit shall be designed to limit the electrical energy to wire leads into the chamber under normal or fault conditions to not more than 28 V and 4.0 W. This requirement shall not exclude more stringent requirements imposed by other codes governing electromedical apparatus.

**14.2.7.6.1.2** Communications wires shall be protected from physical damage and from coming into contact with flammable materials in the chamber by barriers or conduit.

**14.2.7.6.1.3** Patient monitoring leads shall be part of approved electromedical apparatus meeting the requirements in 14.2.7.3.17.

**14.2.7.6.2** Lighting inside the chamber shall be supplied from external sources.

**14.2.7.6.3** No materials shall be permitted in a Class B chamber whose temperature exceeds 50° C (122° F), nor shall any electrical circuit inside a Class B chamber operate at a temperature exceeding 50° C (122° F).

**14.2.8 Communications and Monitoring.**

**14.2.8.1 General.**

**14.2.8.1.1** Detectors, sensors, transducers, and communications equipment located inside the chamber shall meet the requirements of 14.2.7.3.16.

**14.2.8.1.2** Wiring methods in the chamber shall meet the applicable requirements in 14.2.7.3.

**14.2.8.1.3** The following equipment shall be installed outside the chamber or shall meet the requirements of 14.2.7.3.16:

- (1) Control equipment
- (2) Power amplifiers
- (3) Output transformers
- (4) Monitors associated with communications and monitoring equipment

**14.2.8.2\* Intercommunications.**

**14.2.8.2.1\*** An intercommunications system shall connect all personnel compartments (locks) and the chamber operator's control console.

**14.2.8.2.2** Oxygen mask microphones shall be intrinsically safe at the maximum proposed pressure and  $95 \pm 5$  percent oxygen.

**14.2.8.3 Combustible Gas Detection.**

**14.2.8.3.1** The chamber atmosphere shall be continuously monitored for combustible gas concentrations whenever any volatile agents are used in the chamber. (See 14.2.4.3.3.1.)

**14.2.8.3.1.1** The monitor shall be set to provide audible and visual alarms at 10 percent lower explosive limit (LEL) for the particular gas used.

**14.2.8.4 Oxygen Monitoring.**

**14.2.8.4.1** Oxygen levels shall be continuously monitored in any chamber in which nitrogen or other diluent gas is added to the chamber to reduce the volumetric concentration of oxygen in the atmosphere.

**14.2.8.4.1.1** Oxygen monitors shall be equipped with audible and visual alarms.

**14.2.8.4.2** Oxygen levels shall be continuously monitored in Class A chambers when breathing mixtures containing in excess of 21 percent oxygen by volume are being breathed by patients or attendants or any flammable agents are present in the chamber, or when either of these conditions exists.

**14.2.8.4.2.1** Audible and visual alarms shall indicate volumetric oxygen concentrations in excess of 23.5 percent.

**14.2.8.5 Carbon Dioxide Monitoring.** The chamber atmosphere shall be monitored for carbon dioxide levels during saturation operations whenever ventilation is not used.

**14.2.8.6\* Chamber Gas Supply Monitoring.**

**14.2.8.6.1\*** Air from compressors shall be sampled at least every 6 months and after major repair or modification of the compressor(s).

**14.2.8.6.2\*** As a minimum, the air supplied from compressors to Class A chambers shall meet the requirements for CGA Grade E.

**14.2.8.6.3** As a minimum, the air supplied from compressors to Class B chambers shall meet the requirements for CGA Grade E with the additional limit of no condensable hydrocarbons.

**14.2.8.6.4** When air cylinders are used to provide breathing air in Class A or Class B chambers, the breathing air shall be medical air USP.

**14.2.8.6.5** When cylinders are used to provide oxygen in Class A or Class B chambers, the gas shall be oxygen USP.

**14.2.8.7** Electrical monitoring equipment used inside the chamber shall comply with the applicable requirements of 14.2.7.

**14.2.8.8\*** Closed-circuit television monitoring of the chamber interior shall be employed for chamber operators who do not have direct visual contact with the chamber interior from their normal operating location.

**14.2.9 Other Equipment and Fixtures.**

**14.2.9.1** All furniture permanently installed in the hyperbaric chamber shall be grounded.

**14.2.9.2\*** Exhaust from all classes of chambers shall be piped outside of the building.

**14.2.9.2.1** Each Class B chamber shall have an independent exhaust line.

**14.2.9.2.2** The point of exhaust shall not create a hazard.

**14.2.9.2.3** The point of exhaust shall not allow reentry of gases into the building.

**14.2.9.2.4** The point of exhaust shall be protected by the provision of a minimum of 0.3 cm (0.12 in.) mesh screen and situated to prevent the intrusion of rain, snow, or airborne debris.

**14.2.9.2.5** The point of exhaust shall be identified as an oxygen exhaust by a sign prohibiting smoking or open flame.

**14.2.9.3** The supply piping for all air, oxygen, or other breathing mixtures from certified commercially supplied cylinders and portable containers shall be provided with a particulate filter of 66 microns or finer.

**14.2.9.3.1** The particulate filter shall meet the construction requirements of ANSI/ASME PVHO-1, *Safety Standard for Pressure Vessels for Human Occupancy*, and be located as close as practical to the source.

**14.3 Administration and Maintenance.**

**14.3.1 General.**

**14.3.1.1 Purpose.** Section 14.3 contains requirements for administration and maintenance that shall be followed as an adjunct to physical precautions specified in Section 14.2.

**14.3.1.2\* Recognition of Hazards.** The nature and recognition of hyperbaric hazards are outlined in Annex B of this document and shall be reviewed by the safety director.

**14.3.1.3 Responsibility.**

**14.3.1.3.1** Personnel having responsibility for the hyperbaric facility, and those responsible for licensing, accrediting, or approving institutions or other facilities in which hyperbaric installations are employed, shall establish and enforce programs to fulfill the provisions of this chapter.

**14.3.1.3.2\*** Each hyperbaric facility shall designate an on-site hyperbaric safety director to be in charge of all hyperbaric equipment and the operational safety requirements of this chapter.

**14.3.1.3.2.1** The safety director shall participate with facility management personnel and the hyperbaric physician(s) in developing procedures for operation and maintenance of the hyperbaric facility.

**14.3.1.3.2.2** The safety director shall make recommendations for departmental safety policies and procedures.

**14.3.1.3.2.3** The safety director shall have the authority to restrict or remove any potentially hazardous supply or equipment items from the chamber.

**14.3.1.3.3\*** The governing board shall be responsible for the care and safety of patients and personnel.

**14.3.1.3.4\*** By virtue of its responsibility for the professional conduct of members of the medical staff of the health care facility, the organized medical staff shall adopt and enforce regulations with respect to the use of hyperbaric facilities located in health care facilities.

**14.3.1.3.4.1** The safety director shall participate in the development of these regulations.

**14.3.1.3.5\*** The safety director shall ensure that electrical, monitoring, life-support, protection, and ventilating arrangements in the hyperbaric chamber are inspected and tested as part of the routine maintenance program of the facility.

**14.3.1.4 Rules and Regulations.**

**14.3.1.4.1\* General.** The administrative, technical, and professional staffs shall jointly develop policies for management of the hyperbaric facility.

**14.3.1.4.1.1** Upon adoption, the management policies shall be available in the facility.

**14.3.1.4.2** The medical director of hyperbaric medicine and the safety director shall jointly develop the minimum staff qualifications, experience, and complement based on the following:

- (1) Number and type of hyperbaric chambers in use
- (2) Maximum treatment capacity
- (3) Type of hyperbaric therapy normally provided

**14.3.1.4.3** All personnel, including those involved in maintenance and repair of the hyperbaric facility, shall be trained on the purpose, application, operation, and limitations of emergency equipment.

**14.3.1.4.4** Emergency procedures specific to the hyperbaric facility shall be established.

**14.3.1.4.4.1\*** All personnel shall be trained in emergency procedures.

**14.3.1.4.4.2** Personnel shall be trained to control the chamber and decompress occupants when all powered equipment has been rendered inoperative.

**14.3.1.4.5\*** Emergency procedures and fire training drills shall be conducted at least annually and documented by the safety director.

**14.3.1.4.6** When an inspection, test, or maintenance procedure of the fire suppression system results in the system being placed out of service, a protocol shall be followed that notifies appropriate personnel and agencies of the planned or emergency impairment.

**14.3.1.4.7** A sign indicating the fire suppression system is out of service shall be conspicuously placed on the operating console until the fire suppression system is restored to service.

**14.3.1.4.8** During chamber operations with an occupant(s) in a chamber, the operator shall be physically present and shall maintain visual or audible contact with the control panel or the chamber occupant(s).

**14.3.1.5 General.**

**14.3.1.5.1 Potential Ignition Sources.**

**14.3.1.5.1.1\*** The following shall be prohibited from inside the chamber and the immediate vicinity outside the chamber:

- (1) Smoking
- (2) Open flames
- (3) Hot objects

**14.3.1.5.1.2** The following shall be prohibited from inside the chamber:

- (1) Personal warming devices (e.g., therapeutic chemical heating pads, hand warmers, pocket warmers)
- (2) Cell phones and pagers
- (3) Sparking toys
- (4) Personal entertainment devices

**14.3.1.5.2 Flammable Gases and Liquids.**

**14.3.1.5.2.1** Flammable agents, including devices such as laboratory burners employing bottled or natural gas and cigarette lighters, shall be prohibited inside the chamber and from the proximity of the compressor intake.

**14.3.1.5.2.2** For Class A chambers, flammable agents used for patient care, such as alcohol swabs, parenteral alcohol-based pharmaceuticals, and topical creams, shall be permitted in the chamber if the following conditions are met:

- (1) Such use is approved by the safety director or other authority having jurisdiction.
- (2)\*The quantities of such agents are limited so that they are incapable of releasing sufficient flammable vapor into the chamber atmosphere to exceed the LEL for the material.
- (3) A safety factor is included to account for the localized concentrations, stratification, and the absence of ventilation.
- (4) The oxygen monitoring requirement of 14.2.8.4.2 is observed.

**14.3.1.5.2.3** Flammable liquids, gases, or vapors shall not be permitted inside any Class B chamber.

**14.3.1.5.3\* Personnel.**

**14.3.1.5.3.1** Antistatic procedures, as directed by the safety director, shall be employed whenever atmospheres containing more than 23.5 percent oxygen by volume are used.

**14.3.1.5.3.2** In Class A and Class B chambers with atmospheres containing more than 23.5 percent oxygen by volume, electrical grounding of the patient shall be ensured by the provision of a high-impedance conductive pathway in contact with the patient's skin.

**14.3.1.5.3.3** Shoes having ferrous nails that make contact with the floor shall not be permitted to be worn in Class A chambers.

**14.3.1.5.4\* Textiles.**

**14.3.1.5.4.1** Except where permitted in 14.3.1.5.4.2, silk, wool, or synthetic textile materials, or any combination thereof, shall be prohibited in Class A or Class B chambers.

**14.3.1.5.4.2** Garments fabricated of 100 percent cotton or a blend of cotton and polyester fabric shall be permitted in Class A chambers equipped with fire protection as specified in 14.2.5 and in Class B chambers.

**14.3.1.5.4.3\*** The physician or surgeon in charge, with the concurrence of the safety director, shall be permitted to use one of the following prohibited items in the chamber:

- (1) Suture material
- (2) Alloplastic devices
- (3) Bacterial barriers
- (4) Surgical dressings
- (5) Biological interfaces
- (6) Synthetic textiles

**14.3.1.5.4.4** Physician and safety director approval to use prohibited items shall be stated in writing for all prohibited materials employed. (*See A.14.3.1.3.2.*)

**14.3.1.5.5** The use of flammable hair sprays, hair oils, and skin oils shall be forbidden for all chamber occupants/patients as well as personnel.

**14.3.1.5.5.1** Whenever possible, patients shall be stripped of all clothing, particularly if it is contaminated by dirt, grease, or solvents, and then reclothed. (*See A.14.3.1.5.4.*)

**14.3.1.5.5.2** All cosmetics, lotions, and oils shall be removed from the patient's body and hair.

**14.3.1.5.6** All other fabrics used in the chamber, such as sheets, drapes, and blankets, shall conform to 14.3.1.5.4.1 and 14.3.1.5.4.2.

**14.3.1.5.7** Clothing worn by patients in Class A or Class B chambers and personnel in Class A chambers shall, prior to each treatment, conform to the following:

- (1) They shall be issued by the hyperbaric facility or specifically approved by the safety director for hyperbaric use.
- (2) They shall be uncontaminated.
- (3) They shall be devoid of prohibited articles prior to chamber pressurization.

### **14.3.2 Equipment.**

**14.3.2.1** All equipment used in the hyperbaric chamber shall comply with Section 14.2, including the following:

- (1) All electrical and mechanical equipment necessary for the operation and maintenance of the hyperbaric facility
- (2) Any medical devices and instruments used in the facility

**14.3.2.1.1** Use of unapproved equipment shall be prohibited. (See 14.3.1.5.4.3.)

**14.3.2.1.2** The following devices shall not be operated in the hyperbaric chamber unless approved by the safety director for such use:

- (1) Portable X-ray devices
- (2) Electrocautery equipment
- (3) High-energy devices

**14.3.2.1.3** Photographic equipment employing the following shall not remain in the chamber when the chamber is pressurized:

- (1) Photoflash
- (2) Flood lamps

**14.3.2.1.4** The use of Class 1 or Class 2 lasers as defined by ANSI Z136.3 *American National Standard for the Safe Use of Lasers in Health Care Facilities*, shall be permitted.

**14.3.2.1.5** Equipment known to be, or suspected of being, defective shall not be introduced into any hyperbaric chamber or used in conjunction with the operation of such chamber until repaired, tested, and accepted by qualified personnel and approved by the safety director. (See 14.3.1.3.2.)

**14.3.2.1.6\*** Paper brought into the chamber shall be stored in a closed metal container.

**14.3.2.1.7** Containers used for paper storage shall be emptied after each chamber operation.

**14.3.2.1.8** Equipment that does not meet the temperature requirements of 500.8(A), 500.8(B), and 500.8(C) of *NFPA 70, National Electrical Code*, shall not be permitted in the chamber.

**14.3.2.2\*** The following shall be all-metal to the extent possible:

- (1) Oxygen containers
- (2) Valves
- (3) Fittings
- (4) Interconnecting equipment

**14.3.2.3** The following shall be compatible with oxygen under service conditions:

- (1) Valve seats
- (2) Gaskets
- (3) Hose
- (4) Lubricants

**14.3.2.4** Equipment used inside the chamber requiring lubrication shall be lubricated with oxygen-compatible material.

**14.3.2.4.1** Factory-sealed antifriction bearings shall be permitted to be used with standard hydrocarbon lubricants in Class A chambers that do not employ atmospheres of increased oxygen concentration.

**14.3.2.5\*** Equipment made of the following shall be prohibited from the chamber interior:

- (1) Cerium
- (2) Magnesium
- (3) Magnesium alloys

**14.3.2.6\*** In the event that radiation equipment is introduced into a hyperbaric chamber, hydrocarbon detectors shall be installed.

**14.3.2.6.1** In the event that flammable gases are detected in excess of 1000 ppm, radiation equipment shall not be operated until the chamber atmosphere is cleared.

### **14.3.3 Handling of Gases.**

**14.3.3.1** The institution's administrative personnel shall develop policies for safe handling of gases in the hyperbaric facility. (See 14.3.1.5.2.)

**14.3.3.2** Oxygen and other gases shall not be introduced into the chamber in the liquid state.

**14.3.3.3** Flammable gases shall not be used or stored in the chamber or in the hyperbaric facility.

**14.3.3.4\*** Pressurized containers of gas shall be permitted to be introduced into the hyperbaric chamber, provided that the container and its contents are approved for such use by the safety director.

### **14.3.4 Maintenance.**

#### **14.3.4.1 General.**

**14.3.4.1.1** The hyperbaric safety director shall ensure that all valves, regulators, meters, and similar equipment used in the hyperbaric chamber are compensated for use under hyperbaric conditions and tested as part of the routine maintenance program of the facility.

**14.3.4.1.1.1** Pressure relief valves shall be tested and calibrated as part of the routine maintenance program of the facility.

**14.3.4.1.2** The hyperbaric safety director shall ensure that all gas outlets in the chambers are labeled or stenciled in accordance with CGA C-4, *Standard Method of Marking Portable Compressed Gas Containers to Identify the Material Contained*.

**14.3.4.1.3** The requirements set forth in Section 5.1 and NFPA 55, *Compressed Gases and Cryogenic Fluids Code*, concerning the storage, location, and special precautions required for medical gases shall be followed.

**14.3.4.1.4** Storage areas for hazardous materials shall not be located in the room housing the hyperbaric chamber. (See 14.2.1.)

**14.3.4.1.4.1** Flammable gases, except as provided in 14.3.1.5.2.2(1), shall not be used or stored in the hyperbaric room.

**14.3.4.1.5** All replacement parts and components shall conform to original design specification.

#### 14.3.4.2 Maintenance Logs.

**14.3.4.2.1** Installation, repairs, and modifications of equipment related to a chamber shall be evaluated by engineering personnel, tested under pressure, and approved by the safety director.

**14.3.4.2.1.1** Logs of all tests shall be maintained.

**14.3.4.2.2** Operating equipment logs shall be maintained by engineering personnel.

**14.3.4.2.2.1** Operating equipment logs shall be signed before chamber operation by the person in charge. (See A.14.3.1.3.2.)

**14.3.4.2.3** Operating equipment logs shall not be taken inside the chamber.

#### 14.3.5 Electrical Safeguards.

**14.3.5.1** Electrical equipment shall be installed and operated in accordance with 14.2.7.

**14.3.5.1.1** All electrical circuits shall be tested in accordance with the routine maintenance program of the facility.

**14.3.5.1.1.1** Electrical circuit tests shall include the following:

- (1) Ground-fault check to verify that no conductors are grounded to the chamber
- (2) Test of normal functioning (see 14.2.7.2.2)

**14.3.5.1.2** In the event of fire, all nonessential electrical equipment within the chamber shall be de-energized before extinguishing the fire.

**14.3.5.1.2.1** Smoldering, burning electrical equipment shall be de-energized before extinguishing a localized fire involving only the equipment. (See 14.2.5.)

#### 14.3.6\* Electrostatic Safeguards.

**14.3.6.1 Administration. (Reserved)**

**14.3.6.2 Maintenance.**

**14.3.6.2.1 Furniture Used in the Chamber.**

**14.3.6.2.1.1** Conductive devices on furniture and equipment shall be inspected to ensure that they are free of wax, lint, or other extraneous material that could insulate them and defeat the conductive properties.

**14.3.6.2.1.2\*** Casters or furniture leg tips shall not be capable of impact sparking.

**14.3.6.2.1.3** Casters shall not be lubricated with oils or other flammable materials.

**14.3.6.2.1.4** Lubricants shall be oxygen compatible.

**14.3.6.2.1.5** Wheelchairs and gurneys with bearings lubricated and sealed by the manufacturer shall be permitted in Class A chambers where conditions prescribed in 14.2.8.4 are met.

**14.3.6.2.2 Conductive Accessories.** Conductive accessories shall meet conductivity and antistatic requirements.

**14.3.6.2.3\*** Materials containing rubber shall be inspected as part of the routine maintenance program of the facility, especially at points of kinking.

**14.3.6.3 Fire Protection Equipment Inside Hyperbaric Chambers.**

**14.3.6.3.1** Electrical switches, valves, and electrical monitoring equipment associated with fire detection and extinguishment shall be visually inspected before each chamber pressurization.

**14.3.6.3.2** Fire detection equipment shall be tested each week, and full testing, including discharge of extinguishing media, shall be conducted annually.

**14.3.6.3.3** Testing shall include activation of trouble circuits and signals.

**14.3.6.4\* Housekeeping.** A housekeeping program shall be implemented, whether or not the facility is in regular use.

**14.3.6.4.1** The persons assigned to the task of housekeeping shall be trained in the following:

- (1) Potential damage to the equipment from cleaning procedures
- (2) Potential personal injury
- (3) Specific cleaning procedures
- (4) Equipment not to be cleaned

## Chapter 15 Features of Fire Protection

### 15.1 Applicability.

**15.1.1** This chapter shall apply to all new and existing health care facilities, as specified in Section 1.3.

**15.1.2** An existing system that is not in strict compliance with the provisions of this code shall be permitted to be continued in use, unless the authority having jurisdiction has determined that such use constitutes a distinct hazard to life.

**15.2 Construction and Compartmentation.** Buildings or structures housing a health care facility shall meet the minimum construction and compartmentation requirements of the applicable building code; NFPA 101, *Life Safety Code*; or fire code acceptable to the authority having jurisdiction.

**15.3 Special Hazard Protection for Flammable Liquids and Gases.**

**15.3.1** The storage and handling of flammable liquids or gases shall be in accordance with the following applicable standards:

- (1) NFPA 30, *Flammable and Combustible Liquids Code*
- (2) NFPA 54, *National Fuel Gas Code*
- (3) NFPA 58, *Liquefied Petroleum Gas Code* [101:8.7.3.1]

**15.3.2\*** No storage or handling of flammable liquids or gases shall be permitted in any location where such storage would jeopardize egress from the structure, unless otherwise permitted by 15.3.1. [101:8.7.3.2]

**15.4 Laboratories.** Laboratories using chemicals shall comply with NFPA 45, *Standard on Fire Protection for Laboratories Using Chemicals*, unless otherwise modified by other provisions of this code. [101:8.7.4.1]

### 15.5 Utilities.

**15.5.1 General.** Utilities shall comply with the requirements of 15.5.1.1 through 15.5.1.4. [101:12.5.1]

**15.5.1.1 Gas.** Equipment using gas and related gas piping shall be in accordance with NFPA 54, *National Fuel Gas Code*, or NFPA 58, *Liquefied Petroleum Gas Code*, unless such installations are approved existing installations, which shall be permitted to be continued in service. [101:9.1.1]

**15.5.1.2 Electrical Systems.** Electrical wiring and equipment shall be in accordance with NFPA 70, *National Electrical Code*, unless such installations are approved existing installations, which shall be permitted to be continued in service. [101:9.1.2]

**15.5.1.3 Emergency Generators and Standby Power Systems.**

Emergency generators and standby power systems, where required for compliance with this code, shall be installed, tested, and maintained in accordance with NFPA 110, *Standard for Emergency and Standby Power Systems*.

**15.5.1.4 Stored Electrical Energy Systems.** Stored electrical energy systems shall be installed, tested, and maintained in accordance with NFPA 111, *Standard on Stored Electrical Energy Emergency and Standby Power Systems*. [101:9.1.4]

**15.5.2 Heating, Ventilating, and Air-Conditioning.** [101:9.2]

**15.5.2.1\* Heating, Ventilating, and Air Conditioning.** Air-conditioning, heating, ventilating ductwork, and related equipment shall be in accordance with NFPA 90A, *Standard for the Installation of Air-Conditioning and Ventilating Systems*, unless such installations are approved existing installations, which shall be permitted to be continued in service.

**15.5.2.2 Ventilating or Heat-Producing Equipment.** Ventilating or heat-producing equipment shall be in accordance with NFPA 91, *Standard for Exhaust Systems for Air Conveying of Vapors, Gases, Mists, and Noncombustible Particulate Solids*; NFPA 211, *Standard for Chimneys, Fireplaces, Vents, and Solid Fuel-Burning Appliances*; NFPA 31, *Standard for the Installation of Oil-Burning Equipment*; NFPA 54, *National Fuel Gas Code*, or NFPA 70, *National Electrical Code*, as applicable, unless such installations are approved existing installations, which shall be permitted to be continued in service. [101:9.2.2]

**15.5.2.3 Commercial Cooking Equipment.** Commercial cooking equipment shall be in accordance with NFPA 96, *Standard for Ventilation Control and Fire Protection of Commercial Cooking Operations*, unless such installations are approved existing installations, which shall be permitted to be continued in service. [101:9.2.3]

**15.5.2.4 Ventilating Systems in Laboratories Using Chemicals.** Ventilating systems in laboratories using chemicals shall be in accordance with NFPA 45, *Standard on Fire Protection for Laboratories Using Chemicals*. [101:9.2.4]

**15.5.3 Elevators, Escalators, and Conveyors.** [101:9.4]

**15.5.3.1 Code Compliance.** [101:9.4.2]

**15.5.3.1.1** Except as modified herein, new elevators, escalators, dumbwaiters, and moving walks shall be in accordance with the requirements of ASME A17.1/CSA B44, *Safety Code for Elevators and Escalators*. [101:9.4.2.1]

**15.5.3.1.2** Except as modified herein, existing elevators, escalators, dumbwaiters, and moving walks shall conform to the requirements of ASME A17.3, *Safety Code for Existing Elevators and Escalators*. [101:9.4.2.2]

**15.5.3.2 Fire Fighters' Emergency Operations.** [101:9.4.3]

**15.5.3.2.1** All new elevators shall conform to the fire fighters' emergency operations requirements of ASME A17.1/CSA B44, *Safety Code for Elevators and Escalators*. [101:9.4.3.1]

**15.5.3.2.2** All existing elevators having a travel distance of 25 ft (7620 mm) or more above or below the level that best serves the needs of emergency personnel for firefighting or rescue purposes shall conform to the fire fighters' emergency operations requirements of ASME A17.3, *Safety Code for Existing Elevators and Escalators*. [101:9.4.3.2]

**15.5.3.3\* Elevator Machine Rooms.** Elevator machine rooms that contain solid-state equipment for elevators, other than existing elevators, having a travel distance exceeding 50 ft

(15 m) above the level of exit discharge or exceeding 30 ft (9150 mm) below the level of exit discharge shall be provided with independent ventilation or air-conditioning systems to maintain temperature during fire fighters' emergency operations for elevator operation (see 9.3.3). The operating temperature shall be established by the elevator equipment manufacturer's specifications. When standby power is connected to the elevator, the machine room ventilation or air-conditioning shall be connected to standby power. [101:9.4.5]

**15.5.3.4 Elevator Testing.** Elevators shall be subject to periodic inspections and tests as specified in ASME A17.1, *Safety Code for Elevators and Escalators*. All elevators equipped with fire fighters' emergency operations in accordance with 9.3.3 shall be subject to a monthly operation with a written record of the findings made and kept on the premises as required by ASME A17.1. [101:9.4.6]

**15.6 Rubbish Chutes, Incinerators, and Laundry Chutes.** Rubbish chutes, laundry chutes, and incinerators shall be installed and maintained in accordance with NFPA 82, *Standard on Incinerators and Waste and Linen Handling Systems and Equipment*, unless such installations are approved existing installations, which shall be permitted to be continued in service.

**15.6.1** Any rubbish chute, including pneumatic rubbish and linen systems, shall be provided with automatic extinguishing protection in accordance with Section 9.7. [101:19.5.4.3]

**15.7 Fire Detection, Alarm, and Communications Systems.** [101:9.6]

**15.7.1\* General.** [101:9.6.1]

**15.7.1.1** Buildings or structures housing a health care facility shall meet the fire detection, alarm, and communications systems requirements of the applicable building code; NFPA 101, *Life Safety Code*; or fire code acceptable to the authority having jurisdiction.

**15.7.1.2** A fire alarm system required for life safety shall be installed, tested, and maintained in accordance with the applicable requirements of NFPA 70, *National Electrical Code*, and NFPA 72, *National Fire Alarm and Signaling Code*, unless it is an approved existing installation, which shall be permitted to be continued in use. [101:9.6.1.3]

**15.7.1.3** For the purposes of this code, a complete fire alarm system shall provide functions for initiation, notification, and control, which shall perform as follows:

- (1) The initiation function provides the input signal to the system.
- (2) The notification function is the means by which the system advises that human action is required in response to a particular condition.
- (3) The control function provides outputs to control building equipment to enhance protection of life. [101:9.6.1.7]

**15.7.2 Signal Initiation.**

**15.7.2.1** Buildings or structures housing a health care facility shall meet the minimum signaling and alarm initiation requirements of the applicable building code; NFPA 101, *Life Safety Code*; or fire code acceptable to the authority having jurisdiction.

**15.7.2.2** Manual fire alarm boxes shall be used only for fire-protective signaling purposes.

**15.7.2.2.1** Combination fire alarm and guard's tour stations shall be acceptable.

**15.7.2.3** A manual fire alarm box shall be provided in the natural exit access path near each required exit from an area, unless modified by another section of this code.

**15.7.2.4\*** Additional manual fire alarm boxes shall be located so that, on any given floor in any part of the building, no horizontal distance on that floor exceeding 60 m (200 ft) shall need to be traversed to reach a manual fire alarm box. [101:9.6.2.5]

**15.7.2.5** For fire alarm systems using automatic fire detection or waterflow detection devices, not less than one manual fire alarm box shall be provided to initiate a fire alarm signal.

**15.7.2.5.1** The manual fire alarm box shall be located where required by the authority having jurisdiction.

**15.7.2.6** Each manual fire alarm box on a system shall be accessible, unobstructed, and visible. [101:9.6.2.7]

**15.7.2.7** Where a sprinkler system provides automatic detection and alarm system initiation, it shall be provided with an approved alarm initiation device that operates when the flow of water is equal to or greater than that from a single automatic sprinkler.

### 15.7.3 Smoke Alarms.

**15.7.3.1** Where required by the applicable building code; NFPA 101, *Life Safety Code*, or fire code, single-station and multiple-station smoke alarms shall be in accordance with NFPA 72, *National Fire Alarm and Signaling Code*.

**15.7.3.2** System smoke detectors in accordance with NFPA 72, *National Fire Alarm and Signaling Code*, and arranged to function in the same manner as single-station or multiple-station smoke alarms shall be permitted in lieu of smoke alarms. [101:9.6.2.10.1.4]

**15.7.3.3** The alarms shall sound only within an individual dwelling unit, suite of rooms, or similar area and shall not actuate the building fire alarm system, unless otherwise permitted by the authority having jurisdiction. Remote annunciation shall be permitted. [101:9.6.2.10.4]

### 15.7.4 Occupant Notification. [101:9.6.3]

**15.7.4.1** Where required by the applicable building code; NFPA 101, *Life Safety Code*, or fire code, occupant notification shall be provided to alert occupants of a fire or other emergency.

**15.7.4.2** Occupant notification shall be in accordance with 15.7.4.3 unless otherwise provided in 15.7.4.2.1 and 15.7.4.2.2. [101:9.6.3.2]

**15.7.4.2.1\*** Elevator lobby, hoistway, and associated machine room smoke detectors used solely for elevator recall, and heat detectors used solely for elevator power shutdown, shall not be required to activate the building evacuation alarm if the power supply and installation wiring to such detectors are monitored by the building fire alarm system, and if the activation of such detectors initiates a supervisory signal at a constantly attended location. [101:9.6.3.2.1]

**15.7.4.2.2\*** Smoke detectors used solely for closing dampers or HVAC system shutdown shall not be required to activate the building evacuation alarm, provided that the power supply and installation wiring to the detectors are monitored by the building fire alarm system, and the activation of the detectors initiates a supervisory signal at a constantly attended location. [101:9.6.3.2.2]

**15.7.4.3 Defend in Place.** For new and existing facilities, where the response to a fire is to defend in place within a safe place in the building, occupant notification shall be in accordance with the facility fire plan.

**15.7.4.3.1\*** Where buildings are required to be subdivided into smoke compartments, fire alarm notification zones shall coincide with one or more smoke compartment boundaries or shall be in accordance with the facility fire plan.

**15.7.4.3.2\*** The private operating mode, as defined in NFPA 72, shall be permitted to be used for the placement of notification appliances within the health care and ambulatory health care occupancies of the building.

**15.7.4.3.3** The notification signal shall readily identify the smoke zone or the floor area, floor, and building in need of staff response.

**15.7.4.3.4** The notification signal shall be heard in all locations in accordance with the facility fire plan.

**15.7.4.3.5** In critical care areas, visible alarm notification appliances shall be permitted to be used in lieu of audible alarm signals.

**15.7.4.3.6** Visible signals shall not be required inside surgical operating rooms, patient sleeping rooms, or psychiatric care areas where their operation would interfere with patient treatment.

**15.7.4.3.7** Visible signals shall not be required inside exam rooms, special procedure rooms, dressing rooms, and nonpublic toilet rooms where staff is required to respond to those areas in accordance with the facility fire plan.

## 15.8 Automatic Sprinklers and Other Extinguishing Equipment.

### 15.8.1 Automatic Sprinklers.

**15.8.1.1** Automatic sprinkler system shall be installed in accordance with NFPA 13, *Standard for the Installation of Sprinkler Systems*.

**15.8.1.2\* Defend in Place.** For new and existing facilities, where the response to a fire is to defend in place within a safe place in the building and not to automatically evacuate the building, sprinkler system zones shall coincide with smoke compartment boundaries or shall be in accordance with the facility fire plan.

**15.8.1.3\* Closets.** Sprinklers shall not be required in clothes closets of patient sleeping rooms in hospitals where the area of the closet does not exceed 6 ft<sup>2</sup> (0.55 m<sup>2</sup>) provided the distance from the sprinkler in the patient sleeping room to the back wall of the closet does not exceed the maximum distance permitted by NFPA 13, *Standard for the Installation of Sprinkler Systems*. [101:18.3.5.10]

### 15.9 Manual Extinguishing Equipment.

**15.9.1\*** Portable fire extinguishers shall be selected, installed, inspected, and maintained in accordance with NFPA 10, *Standard for Portable Fire Extinguishers*.

**15.9.2** Where provided, standpipe and hose systems shall be in accordance with NFPA 14, *Standard for the Installation of Standpipe and Hose Systems*.

**15.9.2.1** Where standpipe and hose systems are installed in combination with automatic sprinkler systems, installation shall be in accordance with the appropriate provisions established by NFPA 13, *Standard for the Installation of Sprinkler Systems*, and NFPA 14, *Standard for the Installation of Standpipe and Hose Systems*.

**15.9.2.2\*** Hose or hose outlets shall be permitted to be removed from existing standpipe and hose systems that are not required by the applicable building code; NFPA 101, *Life Safety Code*; and fire code.

**15.10\* Compact Storage.** Compact storage shall be protected by sprinklers in accordance with NFPA 13, *Standard for the Installation of Sprinkler Systems*.

**15.11 Compact Mobile Storage.**

**15.11.1** Rooms with compact mobile storage units greater than 50 ft<sup>2</sup> (4.65 m<sup>2</sup>) shall be protected as a hazardous area in accordance with the applicable building code, NFPA 101, *Life Safety Code*, or fire code.

**15.11.2** Smoke detection shall be installed above compact mobile storage units greater than 50 ft<sup>2</sup> (4.65 m<sup>2</sup>) in accordance with NFPA 72.

**15.11.3\*** Compact mobile storage units greater than 50 ft<sup>2</sup> (4.65 m<sup>2</sup>) shall be protected by automatic sprinklers in accordance with NFPA 13.

**15.12 Maintenance and Testing.**

**15.12.1** All water-based fire protection systems shall be inspected, tested, and maintained in accordance with NFPA 25, *Standard for the Inspection, Testing, and Maintenance of Water-Based Fire Protection Systems*.

**15.12.2** All non-water-based fire protection systems shall be inspected, tested, and maintained in accordance with the applicable NFPA standards.

**15.13\* Fire Loss Prevention in Operating Rooms.**

**15.13.1 Hazard Assessment.**

**15.13.1.1** An evaluation shall be made of hazards that could be encountered during surgical procedures.

**15.13.1.2** The evaluation shall include hazards associated with the properties of electricity, hazards associated with the operation of surgical equipment, and hazards associated with the nature of the environment.

**15.13.1.3** Periodic reviews of surgical operations and procedures shall be conducted with special attention given to any change in materials, operations, or personnel.

**15.13.2 Fire Prevention Procedures.** Fire prevention procedures shall be established.

**15.13.3 Germicides and Antiseptics.**

**15.13.3.1** Medicaments and alcohol-based hand sanitizers, including those dispersed as aerosols, shall be permitted to be used in anesthetizing locations.

**15.13.3.2\*** Flammable liquid germicides or antiseptics used in anesthetizing locations, whenever the use of electrosurgery, cautery, or a laser is contemplated, shall be packaged as follows:

- (1) In a nonflammable package
- (2) To ensure controlled delivery to the patient in unit dose applicators, swabs, and other similar applicators

**15.13.3.3** Whenever the application of flammable liquid germicides or antiseptics is employed in surgeries where the use of electrosurgery, cautery, or a laser is contemplated, time shall be allowed to elapse between application of the germicide or antiseptic and the following:

- (1) Application of drapes, to allow complete evaporation and dissipation of any flammable vehicle remaining
- (2) Use of electrosurgery, cautery, or a laser, to ensure the solution is completely dry and to allow thorough evaporation and dissipation of any flammable vehicle remaining

**15.13.3.4** Any solution-soaked materials shall be removed from the operating room prior to draping or use of electrosurgery, cautery, or a laser.

**15.13.3.5** Pooling of flammable liquid germicides or antiseptics shall be avoided; if pooling occurs, excess solution shall be wicked, and the germicide or antiseptic shall be allowed to completely dry.

**15.13.3.6** A preoperative “time out” period shall be conducted prior to the initiation of any surgical procedure using flammable liquid germicides or antiseptics to verify the following:

- (1) Application site of flammable germicide or antiseptic is dry prior to draping and use of electrosurgery, cautery, or a laser.
- (2) Pooling of solution has not occurred or has been corrected.
- (3) Any solution-soaked materials have been removed from the operating room prior to draping and use of electrosurgery, cautery, or a laser.

**15.13.3.7** Whenever flammable aerosols or antiseptics are employed, sufficient time shall be allowed to elapse between deposition and application of drapes to allow complete evaporation and dissipation of any flammable vehicle remaining.

**15.13.3.8** Health care organizations shall establish policies and procedures outlining safety precautions related to the use of flammable liquid or aerosol germicides or antiseptics used in anesthetizing locations, as required in 15.14.1, whenever the use of electrosurgery, cautery, or a laser is contemplated.

**15.13.3.9 Emergency Procedures.**

**15.13.3.9.1** Procedures for operating room/surgical suite emergencies shall be developed.

**15.13.3.9.2** Procedures shall include alarm actuation, evacuation, and equipment shutdown procedures and provisions for control of emergencies that could occur in the operating room, including specific detailed plans for control operations by an emergency control group within the organization or a public fire department.

**15.13.3.9.3** Emergency procedures shall be established for controlling chemical spills.

**15.13.3.9.4** Emergency procedures shall be established for extinguishing drapery, clothing, or equipment fires.

**15.13.3.10 Orientation and Training.**

**15.13.3.10.1** New operating room/surgical suite personnel, including physicians and surgeons, shall be taught general safety practices for the area and specific safety practices for the equipment and procedures they will use.

**15.13.3.10.2** Continuing safety education and supervision shall be provided, incidents shall be reviewed monthly, and procedures shall be reviewed annually.

**15.13.3.10.3** Fire exit drills shall be conducted annually or more frequently as determined by the applicable building code, NFPA 101, *Life Safety Code*, or fire code.

**Annex A Explanatory Material**

*Annex A is not a part of the requirements of this NFPA document but is included for informational purposes only. This annex contains explanatory material, numbered to correspond with the applicable text paragraphs.*

**A.1.1.10** Because no single model of an emergency management plan is feasible for every health care facility, this chapter is intended to provide criteria for the preparation and implementation of an individual plan. The principles involved are universally applicable; the implementation needs to be tailored to the specific facility.



**A.1.1.12** During the past 20 years, there has been a widespread interest in the use of oxygen at elevated environmental pressure to increase the partial pressure of oxygen in a patient's tissues in order to treat certain medical conditions or to prepare a patient for surgery. These techniques are also employed widely for the treatment of decompression sickness (e.g., bends, caisson worker's disease) and carbon monoxide poisoning.

Recently, however, the level of knowledge and expertise has increased so dramatically that the codes are in need of updating. By the end of 1988, there were 218 hyperbaric facilities in operation in the United States and Canada. These facilities supported hyperbaric medical treatments for 62,548 patients between 1971 and 1987. As these facilities provide therapy for disorders indicated for treatment, these numbers will continue to increase. As the number of facilities increases, the number of patients treated will also increase.

Such treatment involves placement of the patient, with or without attendants, in a hyperbaric chamber or pressure vessel, the pressure of which is raised above ambient pressure. In the course of the treatment, the patient breathes up to 100 percent oxygen.

In addition to being used for patient care, these chambers also are being employed for research purposes using experimental animals and, in some instances, humans.

The partial pressure of oxygen present in a gaseous mixture is the determinate factor in the amount of available oxygen. This pressure will rise if the volume percentage of oxygen present increases, if the total pressure of a given gas mixture containing oxygen increases, or if both these factors increase. Because the sole purpose of the hyperbaric technique of treatment is to raise the total pressure within the treatment chamber, an increased partial pressure of oxygen always is available during treatment, unless positive means are taken to limit the oxygen content. In addition, the patient is often given an oxygen-enriched atmosphere to breathe.

The need for human diligence in the establishment, operation, and maintenance of hyperbaric facilities is continual. The chief administrator of the facility possessing the hyperbaric chamber is responsible to adopt and enforce appropriate regulations for hyperbaric facilities. In formulating and administering the program, full use should be made of technical personnel highly qualified in hyperbaric chamber operations and safety.

It is essential that personnel having responsibility for the hyperbaric facility establish and enforce appropriate programs to fulfill the provisions of Chapter 14.

Potential hazards can be controlled only when continually recognized and understood by all pertinent personnel.

The purpose of Chapter 14 is to set forth minimum safeguards for the protection of patients or others subject to, and personnel who administer, hyperbaric therapy and experimental procedures. Its purpose is also to offer some guidance for rescue personnel who are not ordinarily involved in hyperbaric chamber operation, but who could become so involved in an emergency.

Requirements cited in 1.1.12 are minimum requirements. Discretion on the part of chamber operators and others might dictate the establishment of more stringent regulations.

**A.1.5** Although it is common practice for medical appliances to use metric units on their dials, gauges, and controls, many components of systems within the scope of this document are

manufactured and used in the United States and employ non-metric dimensions. Since these dimensions (such as nominal pipe sizes) are not established by the National Fire Protection Association, the Technical Correlating Committee on Health Care Facilities cannot independently change them. Accordingly, this document uses dimensions that are presently in common use by the building trades in the United States. Trade units vary from SI to U.S. customary units, depending on the equipment devices or material.

**A.2.1** The documents referenced in this chapter or portions of such documents are referenced within this code and are considered part of the requirements of this document.

Documents referenced in this chapter or portions of such documents are only applicable to the extent called for within other chapters of this code.

Where the requirements of a referenced code or standard differ from the requirements of this code, the requirements of this code govern.

**A.3.2.1 Approved.** The National Fire Protection Association does not approve, inspect, or certify any installations, procedures, equipment, or materials; nor does it approve or evaluate testing laboratories. In determining the acceptability of installations, procedures, equipment, or materials, the authority having jurisdiction may base acceptance on compliance with NFPA or other appropriate standards. In the absence of such standards, said authority may require evidence of proper installation, procedure, or use. The authority having jurisdiction may also refer to the listings or labeling practices of an organization that is concerned with product evaluations and is thus in a position to determine compliance with appropriate standards for the current production of listed items.

**A.3.2.2 Authority Having Jurisdiction (AHJ).** The phrase "authority having jurisdiction," or its acronym AHJ, is used in NFPA documents in a broad manner, since jurisdictions and approval agencies vary, as do their responsibilities. Where public safety is primary, the authority having jurisdiction may be a federal, state, local, or other regional department or individual such as a fire chief; fire marshal; chief of a fire prevention bureau, labor department, or health department; building official; electrical inspector; or others having statutory authority. For insurance purposes, an insurance inspection department, rating bureau, or other insurance company representative may be the authority having jurisdiction. In many circumstances, the property owner or his or her designated agent assumes the role of the authority having jurisdiction; at government installations, the commanding officer or departmental official may be the authority having jurisdiction.

**A.3.2.3 Code.** The decision to designate a standard as a "code" is based on such factors as the size and scope of the document, its intended use and form of adoption, and whether it contains substantial enforcement and administrative provisions.

**A.3.2.6 Listed.** The means for identifying listed equipment may vary for each organization concerned with product evaluation; some organizations do not recognize equipment as listed unless it is also labeled. The authority having jurisdiction should utilize the system employed by the listing organization to identify a listed product.

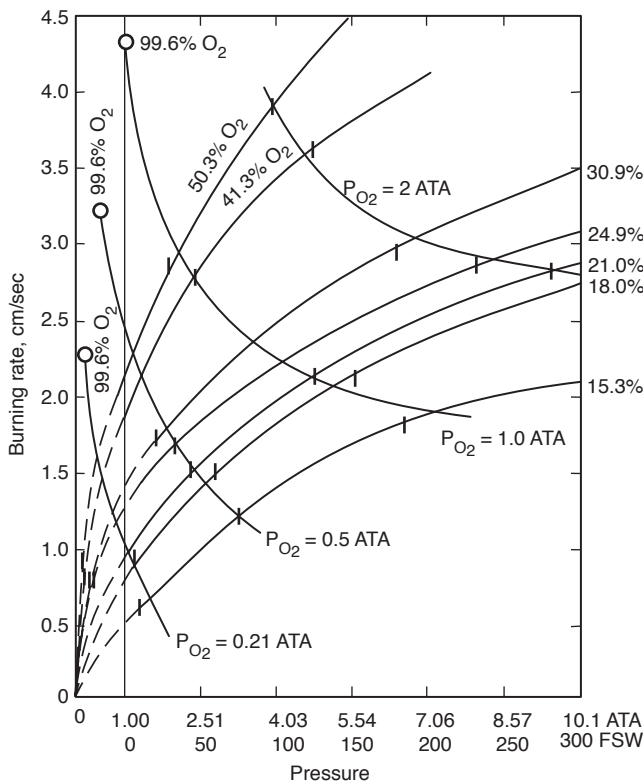
**A.3.3.9 Anesthetizing Location.** Areas used exclusively for sedation are not included in this definition.

**A.3.3.12 Applicator.** In the given sense, an applicator is not an electrode, because it does not use a conductive connection to the patient in order to function. A radio frequency “horn” of a diathermy machine is a typical applicator.

**A.3.3.14 Atmosphere.** As employed in this code, the term *atmosphere* can refer to the environment within or outside of a hyperbaric facility. When used as a measure of pressure, atmosphere is expressed as a fraction of standard air pressure [101.4 kPa (14.7 psi)]. (See the first column of Table D.1 in NFPA 99B.)

**A.3.3.14.3 Atmosphere of Increased Burning Rate.** The degree of fire hazard of an oxygen-enriched atmosphere varies with the concentration of oxygen and diluent gas and the total pressure. The definition contained in the current edition of NFPA 53, *Recommended Practice on Materials, Equipment, and Systems Used in Oxygen-Enriched Atmospheres*, and in editions of NFPA 56D, *Standard for Hyperbaric Facilities*, prior to 1982 did not necessarily reflect the increased fire hazard of hyperbaric and hypobaric atmospheres.

The definition of *atmosphere of increased burning rate* used in Chapter 14 and in NFPA 99B, *Standard for Hypobaric Facilities*, defines an oxygen-enriched atmosphere with an increased fire hazard as it relates to the increased burning rate of material in the atmosphere. It is based on a 1.2 cm/sec (0.47 in./sec) burning rate (at 23.5 percent oxygen at 1 atmosphere absolute) as described in Figure A.3.3.14.3.



ATA = Atmospheres absolute  
FSW = Feet of sea water

**FIGURE A.3.3.14.3 Burning Rates of Filter Paper Strips at an Angle of 45 Degrees in N<sub>2</sub>-O<sub>2</sub> Mixtures. (Adapted from Figure 4 of “Technical Memorandum UCRI-721, Chamber Fire Safety.”)**

This rate can be determined as follows:

$$\frac{23.45}{\sqrt{TP_{atmos}}}$$

where:

$TP_{atmos}$  = total pressure in atmospheres

**A.3.3.21.3 Bulk Oxygen System.** The oxygen containers can be stationary or movable, and the oxygen can be stored as gas or liquid. The bulk oxygen system terminates at the point where oxygen at service pressure first enters the supply line.

**A.3.3.26 Combustible Liquid.** See NFPA 30, *Flammable and Combustible Liquids Code*, for further information on flash point test procedures.

**A.3.3.27 Combustion.** Combustion is not limited to a chemical reaction always involving oxygen. Certain metals, such as calcium and aluminum, will burn in nitrogen; nitrous oxide will support the combustion of phosphorus and carbon; and so on. However, this document deals with the more common process of fuels burning in air.

**A.3.3.35 Defend in Place.** The concept of the term *defend in place* includes, but is not limited to, elements related to moving building occupants from an area of immediate danger to a safe location in the building and containment of the emergency or dangerous condition.

**A.3.3.38 Direct Electrical Pathway to the Heart.** Electrodes, such as those used for pacing the heart, and catheters filled with conductive fluids, are examples of direct electrical pathways to the heart.

**A.3.3.39 Disaster.** A disaster can be either an event that causes, or threatens to cause, physical damage and injury to facility personnel or patients within the facility, or an event that requires expansion of facilities to receive and care for a large number of casualties resulting from a disaster that produces no damage or injury to the health care facility and staff, or a combination thereof.

Such a situation creates the need for emergency expansion of facilities, as well as operation of this expanded facility in an unfamiliar environment. Under this definition, the recognition of a disaster situation will vary greatly from one facility to another and from time to time in any given facility. Such recognition and concomitant activation of the Health Care Emergency Preparedness Plan is dependent on mutual aid agreements, facility type, geographic location, bed capacity, bed occupancy at a given time, staff size, staff experience with disaster situations, and other factors. For example, the routine workload of the emergency department of a large metropolitan general hospital would constitute a disaster, requiring activation of the Health Care Emergency Preparedness Plan, were this same workload to be suddenly applied to a small community hospital.

Disasters have a variety of causes, all of which should be considered for effective emergency preparedness planning. Among the most common are natural disasters such as earthquakes, hurricanes, tornadoes, and floods; mass food poisoning; industrial accidents involving explosion or environmental release of toxic chemicals; transportation accidents involving crashes of trains, planes, or automobiles with resulting mass casualties; civil disturbances; building fires; extensive or prolonged utility failure; collapse of buildings or other occupied structures; and toxic smogs in urban areas. Arson attempts and bomb threats have been made on health care facilities and should, therefore, be considered. Potential admission to the

facility of high profile persons should be addressed. Although a high profile admission does not involve mass casualties or the potential for mass casualties, the degree of disruption of normal routine will be sufficient to qualify it as a disasterlike situation.

Disaster plans should reflect a facility's location from potential internal and external disasters. As an example, areas subject to frequent wildland fires should invoke countermeasures for smoke management and air quality maintenance.

**A.3.3.41 Double-Insulated Appliances.** Double-insulated appliances can be identified by a symbol consisting of a square within a square or wording such as "double-insulated" marked on the appliance. Appliance packaging and documents can also provide identification. Although double-insulated appliances do not require a third wire or pin, some double-insulated appliances have a third conductor or pin solely for purposes of electromagnetic compatibility (EMC).

**A.3.3.43.3 Dispersive Electrode.** A dispersive electrode is often called the grounding electrode, the "indifferent electrode," the "return electrode," the "patient ground plate," or the "neutral electrode."

**A.3.3.48 Essential Electrical System.** The essential electrical system can be comprised of three branches: life safety branch, critical branch, and equipment branch.

**A.3.3.51 Failure.** Failure includes failure of a component; loss of normal protective paths, such as grounding; and short circuits or faults between energized conductors and the chassis.

**A.3.3.54 Flammable.** Flammables can be solids, liquids, or gases exhibiting these qualities. Many substances that are non-flammable in air become flammable if the oxygen content of the gaseous medium is increased above 0.235 ATA.

**A.3.3.57 Flash Point.** Note that the flash point temperature is heavily dependent on the test used to determine it. (See also B.11.1.2.)

**A.3.3.60 Frequency.** Formerly, the unit of frequency was cycles per second, a terminology no longer preferred. The waveform can consist of components having many different frequencies, in which case it is called a complex or nonsinusoidal waveform.

**A.3.3.61 Fume Hood.** Laboratory fume hoods prevent toxic, flammable, or noxious vapors from entering the laboratory; present a physical barrier from chemical reactions; and serve to contain accidental spills.

This definition does not include canopy hoods or recirculation laminar-flow biological-safety cabinets that are not designed for use with flammable materials.

**A.3.3.63 General Anesthesia and Levels of Sedation/Analgesia.** It should be noted that these are not static conditions. Minimal sedation can easily become moderate sedation, and moderate sedation can progress to deep sedation or general anesthesia.

**A.3.3.68 Grounding System.** It coordinates with, but can be locally more extensive than, the grounding system described in Article 250 of *NFPA 70, National Electrical Code*.

**A.3.3.70 Hazardous Chemical.** For hazard ratings of many chemicals, see NFPA 49, *Hazardous Chemicals Data*, and NFPA 325, *Guide to Fire Hazard Properties of Flammable Liquids, Gases, and Volatile Solids*, both available in NFPA's *Fire Protection Guide to Hazardous Materials*.

**A.3.3.71 Health Care Facilities.** Health care facilities include, but are not limited to, hospitals, nursing homes, limited care facilities, clinics, medical and dental offices, and ambulatory health care centers, whether permanent or movable. This definition applies to normal, regular operations and does not pertain to facilities during declared local or national disasters. A health care facility is not a type of occupancy classification as defined by NFPA 101, *Life Safety Code*. Therefore, the term *health care facility* should not be confused with the term *health care occupancy*. All health care occupancies (and ambulatory health care occupancies) are considered health care facilities; however, not all health care facilities are considered health care occupancies, as health care facilities also include ambulatory health care occupancies and business occupancies.

**A.3.3.82 Impedance.** The circuit element can consist of any combination of resistance, capacitance, or inductance.

**A.3.3.86 Intrinsically Safe.** "Abnormal conditions" can include accidental damage to any part of the equipment or wiring, damage to insulation or other failure of electrical components, application of overvoltage, adjustment and maintenance operations, and other similar conditions.

**A.3.3.89 Isolated Power System.** See *NFPA 70, National Electrical Code*.

**A.3.3.91 Laboratory.** These laboratories are not intended to include isolated frozen section laboratories; areas in which oxygen is administered; blood donor rooms in which flammable, combustible, or otherwise hazardous materials normally used in laboratory procedures are not present; and clinical service areas not using hazardous materials.

**A.3.3.92 Laboratory Work Area.** See NFPA 45, *Standard on Fire Protection for Laboratories Using Chemicals*.

**A.3.3.96 Limited-Combustible (Material).** Material subject to increase in combustibility or flame spread index beyond the limits herein established through the effects of age, moisture, or other atmospheric condition is considered combustible.

See NFPA 259, *Standard Test Method for Potential Heat of Building Materials*, and NFPA 220, *Standard on Types of Building Construction*.

**A.3.3.98 Liquid.** When not otherwise identified, the term *liquid* includes both flammable and combustible liquids. (See also B.11.1.1.)

**A.3.3.99 Local Signal.** Examples would include a gauge, a flag, a light, or some other possible manifestation that allows a maintenance person to stand at the equipment and know what conditions are present (e.g., which header of cylinders is in service). The elements to be displayed are typically those that will also be monitored at the master alarm, but the local signal is visible at the equipment rather than remotely.

**A.3.3.102 Manufactured Assembly.** Examples are headwalls, columns, ceiling columns, ceiling-hung pendants, movable track systems, and so on.

**A.3.3.104 Medical Air.** Air supplied from on-site compressors and associated air treatment systems (as opposed to medical air USP supplied in cylinders) that complies with the specified limits is considered medical air. Hydrocarbon carryover from the compressor into the pipeline distribution system could be detrimental to the safety of the end user and to the integrity of the piping system. Mixing of air and oxygen is a common clinical practice, and the hazards of fire are increased if the air is thus contaminated. Compliance with these limits is thus considered important to fire and patient safety. The quality of local ambient air should be determined prior to its selection for compressors and air treatment equipment.

**A.3.3.106 Medical/Dental Office.** Examples include a dental office/clinic, a medical office/clinic, an immediate care facility, and a podiatry office.

**A.3.3.125 Nonflammable Anesthetic Agent.** It is possible to halogenate a compound and render it partially or totally nonflammable by the substitution of one or more halogens (e.g., fluorine, chlorine, bromine) for hydrogen. Thus, halothane ( $\text{CF}_3\text{CHClBr}$ ) is almost completely halogenated and is nonflammable. Methoxyflurane ( $\text{CHF}_2\text{CCl}_2\text{OCH}_3$ ) is partially halogenated and is nonflammable in conditions encountered during clinical anesthesia (if it is heated, its vapor concentration will increase enough to burn). Fluroxene ( $\text{CF}_3\text{CH}_2\text{OCHCH}_2$ ) is halogenated even less; it is flammable in concentrations of 4 percent or greater.

The following agents are considered flammable during conditions of clinical use in anesthesia:

- (1) Cyclopropane
- (2) Divinyl ether
- (3) Ethyl chloride
- (4) Ethylene
- (5) Ethyl ether

Fluroxene is an agent that is flammable during use in clinical anesthesia in higher concentrations. Because fluroxene is flammable under certain conditions of use, it is listed as a flammable agent. Concentrations required for induction of anesthesia generally exceed 4 percent and are flammable. However, maintenance of fluroxene anesthesia can be accomplished with concentrations of less than 4 percent.

The following agents are nonflammable during conditions of use in clinical anesthesia:

- (1) Chloroform
- (2) Halothane
- (3) Methoxyflurane
- (4) Nitrous oxide
- (5) Trichloroethylene
- (6) Enflurane

**A.3.3.126 Nonflammable Medical Gas System.** See Chapter 5, Gas and Vacuum Systems.

**A.3.3.128 Oxidizing Gas.** Oxygen and nitrous oxide are examples of oxidizing gases. There are many others, including halogens.

**A.3.3.129 Oxygen.** Oxygen's outstanding property is its ability to sustain life and to support combustion. Although oxygen is nonflammable, materials that burn in air will burn much more vigorously and create higher temperatures in oxygen or in oxygen-enriched atmospheres.

**A.3.3.129.2 Liquid Oxygen.** If spilled, the liquid can cause frostbite on contact with skin.

**A.3.3.130 Oxygen Delivery Equipment.** If an enclosure such as a mask, hood, incubator, canopy, or tent is used to contain the oxygen-enriched atmosphere, that enclosure is considered to be oxygen-delivery equipment.

**A.3.3.132 Oxygen Hood.** For additional information, see A.3.3.14.3 and Figure A.3.3.14.3.

**A.3.3.134 Oxygen Toxicity (Hyperbaric).** Under the pressures and times of exposure normally encountered in hyperbaric treatments, toxicity is a direct function of concentration and time of exposure.

**A.3.3.138 Patient Care Room.** Business offices, corridors, lounges, day rooms, dining rooms, or similar areas typically are not classified as patient care rooms.

**A.3.3.138.1 Basic Care Room.** These rooms are typically where basic medical or dental care, treatment, or examinations are performed. Examples include, but are not limited to, examination or treatment rooms in clinics, medical and dental offices, nursing homes, and limited care facilities. (MED)

**A.3.3.138.2 Critical Care Room.** These rooms are typically where patients are intended to be subjected to invasive procedures and connected to line-operated, patient care-related appliances. Examples include, but are not limited to, special care patient rooms used for critical care, intensive care, and special care treatment rooms such as angiography laboratories, cardiac catheterization laboratories, delivery rooms, operating rooms, post-anesthesia care units, trauma rooms, and other similar rooms.

**A.3.3.138.3 General Care Room.** Examples include, but are not limited to, inpatient bedrooms, dialysis rooms, in vitro fertilization rooms, procedural rooms, and similar rooms.

**A.3.3.138.4 Support Room.** Examples of support rooms include, but are not limited to, anesthesia work rooms, sterile supply, laboratories, morgues, waiting rooms, utility rooms, and lounges.

**A.3.3.141 Patient Lead.** A patient lead can be a surface contact (e.g., an ECG electrode), an invasive connection (e.g., implanted wire or catheter), or an incidental long-term connection (e.g., conductive tubing).

It is not intended to include adventitious or casual contacts, such as a push button, bed surface, lamp, hand-held appliance, and so forth.

*(Also see 3.3.85, Isolated Patient Lead.)*

**A.3.3.147.5 Partial Pressure.** The pressure contributed by other gases in the mixture is ignored. For example, oxygen is one of the constituents of air; the partial pressure of oxygen in standard air, at a standard air pressure of 14.7 psia, is 3.06 psia or 0.208 ATA or 158 mm Hg.

**A.3.3.147.7 Working Pressure.** A pipeline working pressure of  $2.9 \text{ kg/cm}^2$  to  $3.2 \text{ kg/cm}^2$  (50 psig to 55 psig) is conventional because medical gas equipment is generally designed and calibrated for use at this pressure.

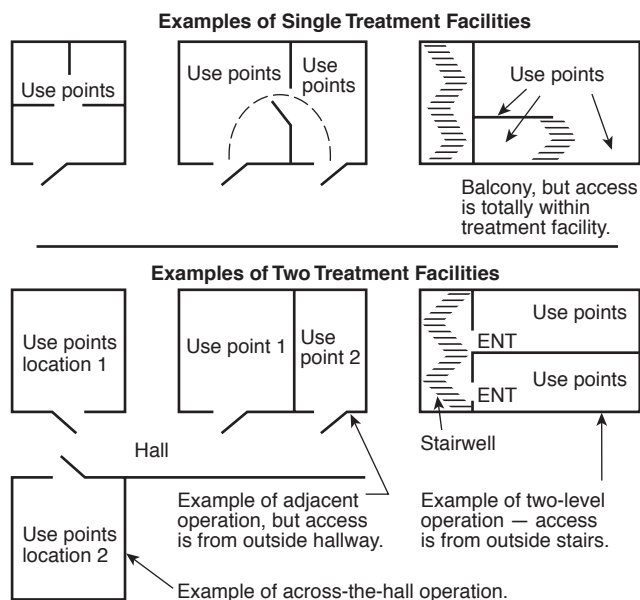
**A.3.3.148 Pressure-Reducing Regulator.** In hospitals, the term *regulator* is frequently used to describe a regulator that incorporates a flow-measuring device.

**A.3.3.151 psig.** Under standard conditions, 0 psig is equivalent to 14.7 psia.

**A.3.3.156 Refrigerating Equipment.** Refrigerating equipment includes refrigerators, freezers, and similar equipment.

**A.3.3.157 Remote.** A gas storage supply system can be remote from the single treatment facility, but all use points must be contiguous within the facility.

**A.3.3.167 Single Treatment Facility.** The definition of single treatment facility was established to take into consideration principally single-level installations or those of a practice that could be two-level, but are reached by open stairs within the confines of the single treatment facility. (See Figure A.3.3.167.)



**FIGURE A.3.3.167** Examples of Treatment Facilities.

**A.3.3.168 Site of Intentional Expulsion.** This definition addresses the site of intended expulsion. Actual expulsion can occur at other sites remote from the intended site due to disconnections, leaks, or rupture of gas conduits and connections. Vigilance on the part of the patient care team is essential to ensure system integrity.

For example, for a patient receiving oxygen via a nasal cannula or face mask, the site of expulsion normally surrounds the mask or cannula; for a patient receiving oxygen while enclosed in a canopy or incubator, the site of intentional expulsion normally surrounds the openings to the canopy or incubator; for a patient receiving oxygen while on a ventilator, the site of intentional expulsion normally surrounds the venting port on the ventilator.

**A.3.3.172 Surface-Mounted Medical Gas Rail Systems.** It is the intent that surface-mounted medical gas rail systems would be permitted in individual patient rooms but would not be permitted to go directly through room walls to adjacent patient rooms. However, it is the intent to permit surface-mounted medical gas rails to be used in a given critical care area where there can be a partition separating certain patient care functions, essentially leaving the system within the given critical care area. As an example, two adjacent patient rooms outside of a critical care unit would not be permitted to have a surface-mounted medical gas rail interconnect between the two rooms through the wall. However, in a nursery where there might be one or two segregated areas for isolation, a medical gas rail system supplying more than one isolation room, but within the nursery area, would be permitted to be interconnected with the nursery system.

**A.3.3.177.1 Endotracheal Tube.** An endotracheal tube can be equipped with an inflatable cuff.

**A.3.3.177.2 Tracheotomy Tube.** A tracheotomy tube can be equipped with an inflatable cuff.

**A.3.3.178 Unattended Laboratory Operation.** Absence for lunch, telephone calls, and so forth, without coverage by a

knowledgeable person, constitutes an unattended laboratory operation. [45, 2011]

**A.3.3.180 Utility Center (J Box).** A utility center typically includes an electrical receptacle(s), compressed air, nitrogen, vacuum, and water.

**A.3.3.182 WAGD Interface.** Interfaces are provided with overpressure, underpressure, overflow, and underflow compensation to ensure the breathing circuit is isolated from the WAGD system.

**A.3.3.184 Wet Procedure Locations.** Routine housekeeping procedures and incidental spillage of liquids do not define a wet procedure location.

**A.4.1** Four levels of systems categories are defined in this code, based on the risks to patients and caregivers in the facilities. The categories are as follows:

- (1) Category 1: Systems are expected to work or be available at all times to support patient needs.
- (2) Category 2: Systems are expected to provide a high level of reliability; however, limited short durations of equipment downtime can be tolerated without significant impact on patient care. Category 2 systems support patient needs but are not critical for life support.
- (3) Category 3: Normal building system reliabilities are expected. Such systems support patient needs, but failure of such equipment would not immediately affect patient care. Such equipment is not critical for life support.
- (4) Category 4: Such systems have no impact on patient care and would not be noticeable to patients in the event of failure.

The category definitions apply to equipment operations and are not intended to consider intervention by caregivers or others. Potential examples of areas/systems and their categories of risk follow. A risk assessment should be conducted to evaluate the risk to the patients, staff, and visitors.

- (1) Ambulatory surgical center, two patients with full OR services, Category 1
- (2) Reconstructive surgeon's office with general anesthesia, Category 1
- (3) Procedural sedation site for outpatient services, Category 2
- (4) Cooling Towers in Houston, TX, Category 2
- (5) Cooling Towers in Seattle, WA, Category 3
- (6) Dental office, no general anesthesia, Category 3
- (7) Typical doctor's office/exam room, Category 4
- (8) Lawn sprinkler system, Category 4

**A.4.1.1** Major injury can include the following:

- (1) Any amputation
- (2) Loss of the sight of an eye (whether temporary or permanent)
- (3) Chemical or hot metal burn to the eye or any penetrating injury to the eye
- (4) Any injury that results in electric shock and electric burns leading to unconsciousness and that requires resuscitation or admittance to a hospital for 24 hours or more
- (5) Any other injury leading to hypothermia, heat induced illness, or unconsciousness requiring resuscitation or admittance to a hospital for 24 hours or more
- (6) Loss of consciousness caused by asphyxia or lack of oxygen or exposure to a biological agent or harmful substance
- (7) Absorption of any substance by inhalation, skin, or ingestion causing loss of consciousness or acute illness requiring medical treatment
- (8) Acute illness requiring medical treatment where there is reason to believe the exposure was to biological agents, its toxins, or infected materials

**A.4.1.2** A minor injury means *not serious* or *involving risk of life*.

**A.4.2** Risk assessment should follow procedures such as those outlined in ISO/IEC 31010, *Risk Management — Risk Assessment Techniques*, NFPA 551, *Guide for the Evaluation of Fire Risk Assessments*, SEMI S10-0307E, *Safety Guideline for Risk Assessment and Risk Evaluation Process*, or other formal process. The results of the assessment procedure should be documented and records retained.

**A.5.1.1** Section 5.1 covers requirements for Category 1 piped gas and vacuum systems; Section 5.2 covers Category 2 piped gas and vacuum systems; and Section 5.3 covers Category 3 piped gas and vacuum systems. Laboratory systems are no longer covered by Chapter 5 (2002 edition).

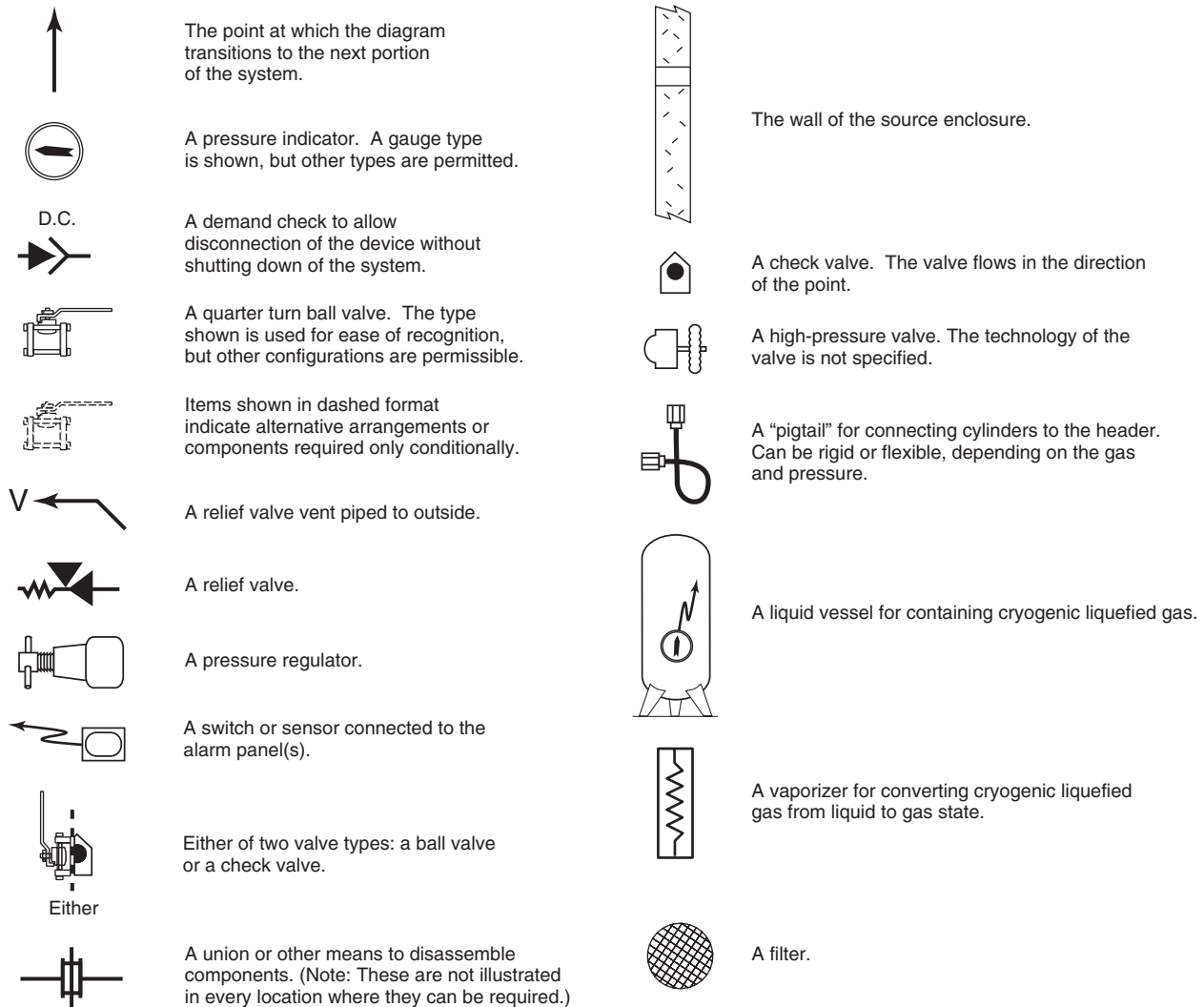
**A.5.1.1.2** These requirements do not restrict the distribution of other inert gases through piping systems.

**A.5.1.1.3** See Figure A.5.1.3. Category 1 source drawings in this annex are representational, demonstrating a possible arrange-

ment of components required by the text. The diagrams are not intended to imply method, materials of construction, or more than one of many possible and equally compliant arrangements. Alternative arrangements are permitted if they meet the intent of the text. Listed paragraphs might not be the only paragraphs that apply.

**A.5.1.3.1.1** Regulations of the U.S. Department of Transportation (formerly U.S. Interstate Commerce Commission) outline specifications for transportation of explosives and dangerous articles (49 CFR 171–190). In Canada, the regulations of the Canadian Transport Commission, Union Station, Ottawa, Ontario, apply.

**A.5.1.3.3** The bulk supply system should be installed on a site that has been prepared to meet the requirements of NFPA 55, *Compressed Gases and Cryogenic Fluids Code*, or CGA G-8.1, *Standard for Nitrous Oxide Systems at Consumer Sites*. A storage unit(s), reserve, pressure regulation, and a signal actuating switch(es)



**FIGURE A.5.1.3** Legend for Typical Category 1 Source Drawings.

are components of the supply system. Shutoff valves, piping from the site, and electric wiring from a signal switch(es) to the master signal panels are components of the piping system.

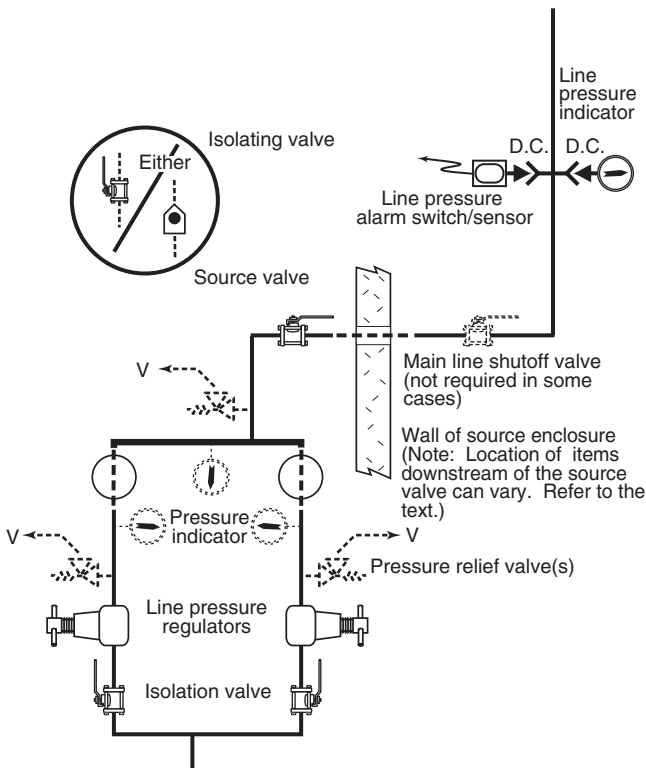
The bulk supply system is normally installed on the site by the owner of this equipment. The owner or the organization responsible for the operation and maintenance of the bulk supply system is responsible for ensuring that all components of the supply system — main supply, reserve supply, supply system signal-actuating switch(es), and delivery pressure regulation equipment — function properly before the system is put in service.

**A.5.1.3.3.1.13** Examples of inert gases include but are not limited to helium and nitrogen.

**A.5.1.3.3.2** Electric wiring and equipment in storage rooms for oxygen and nitrous oxide are not required to be explosion-proof.

**A.5.1.3.3.2(5)** Electrical devices should be physically protected, such as by use of a protective barrier around the electrical devices, or by location of the electrical device such that it will avoid causing physical damage to the cylinders or containers. For example, the device could be located at or above 1.5 m (5 ft) above finished floor or other location that will not allow the possibility of the cylinders or containers to come into contact with the electrical device as required by this section.

**A.5.1.3.3.2(8)** Chapter 6 specifies medical gas equipment that should be powered by the essential electrical systems. Electrical equipment that is not essential for the operation of the supply system can be powered by nonessential power (e.g., telemetry, site lighting).



**FIGURE A.5.1.3.5** Typical Arrangement for Line Controls at Pressure Sources.

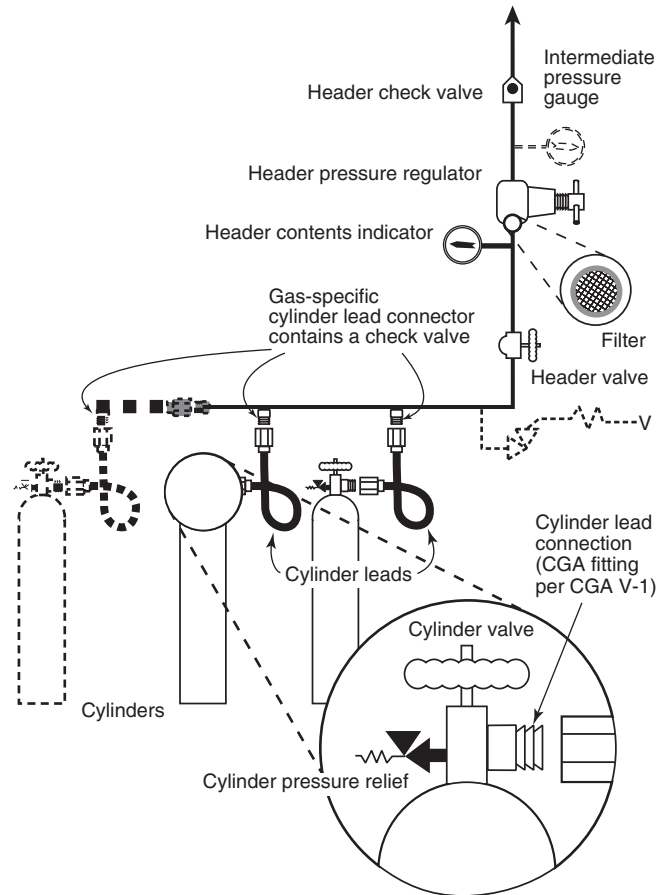
**A.5.1.3.5** See Figure A.5.1.3.5. A four-valve bypass arrangement is illustrated. Three-way valves are permitted in lieu of the four valves shown.

**A.5.1.3.5.4** Components include, but are not limited to, containers, valves, valve seats, lubricants, fittings, gaskets, and interconnecting equipment, including hose. Easily ignitable materials should be avoided.

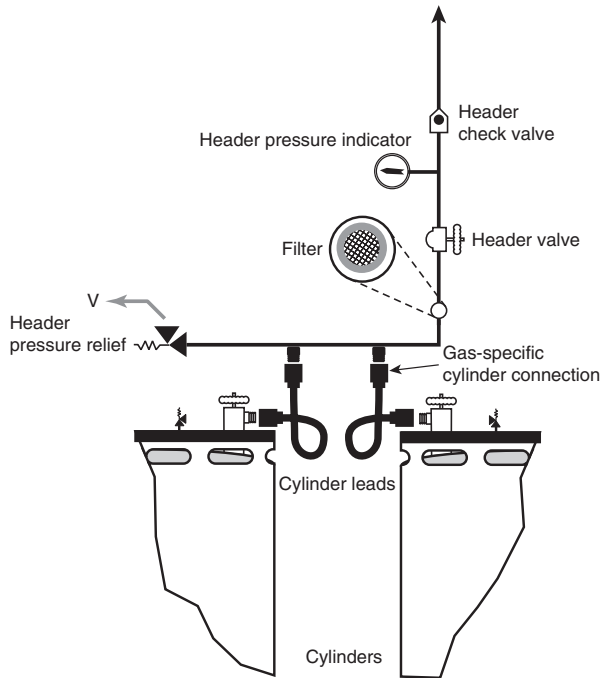
Compatibility involves both combustibility and ease of ignition. Materials that burn in air will burn violently in pure oxygen at normal pressure and explosively in pressurized oxygen. Also, many materials that do not burn in air will do so in pure oxygen, particularly under pressure. Metals for containers and piping have to be carefully selected, depending on service conditions. The various steels are acceptable for many applications, but some service conditions can call for other materials (usually copper or its alloys) because of their greater resistance to ignition and lower rate of combustion.

Similarly, materials that can be ignited in air have lower ignition energies in oxygen. Many such materials can be ignited by friction at a valve seat or stem packing or by adiabatic compression produced when oxygen at high pressure is rapidly introduced into a system initially at low pressure.

**A.5.1.3.5.9** See Figure A.5.1.3.5.9(a) and Figure A.5.1.3.5.9(b). Connection to the gas outlet connection is illustrated. If the liquid outlet connection were used, an external vaporizer could be required.



**FIGURE A.5.1.3.5.9(a)** Header for Gas in Cylinders.



**FIGURE A.5.1.3.5.9(b) Header for Cryogenic Gas in Containers.**

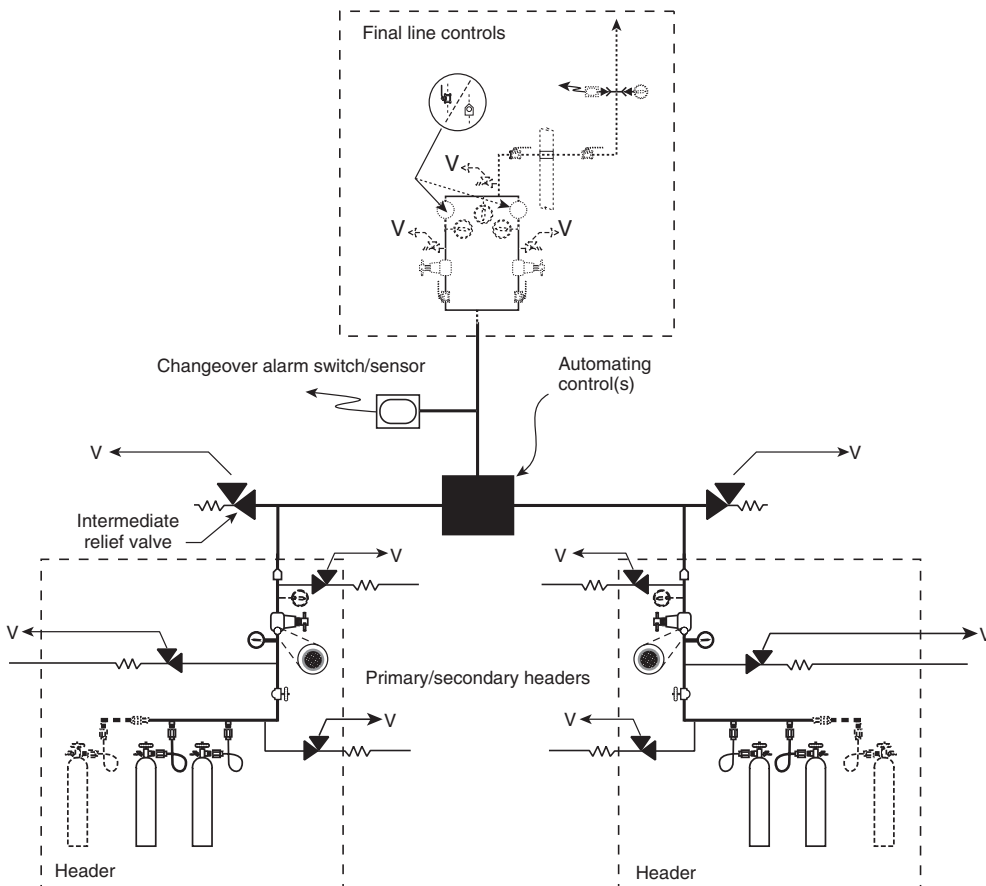
**A.5.1.3.5.9(1)** The appropriate number of cylinders should be determined after consideration of delivery schedules, proximity of the facility to alternate supplies, and the emergency plan.

**A.5.1.3.5.10** See Figure A.5.1.3.5.10.

**A.5.1.3.5.11** See Figure A.5.1.3.5.11.

**A.5.1.3.5.12** For bulk oxygen systems, see NFPA 55, *Compressed Gases and Cryogenic Fluids Code*. See Figure A.5.1.3.5.12(a) and Figure A.5.1.3.5.12(b). Two possible choices of reserves are illustrated. Both are not required.

**A.5.1.3.5.12.4** The local signal arose from the simple need of a maintenance person to know what is going on with any given piece of source equipment. Note that it is not an alarm in the sense of a local or master alarm. It is simply an indicator, which might be a gauge, a flag, a light, or some other possible manifestation that allows a maintenance person to stand at the equipment and know what conditions are present (e.g., which header of cylinders is in service). The elements to be displayed are typically those that will also be monitored at the master alarm, but the local signal is visible at the equipment rather than remotely.



**FIGURE A.5.1.3.5.10 Manifold for Gas Cylinders.**



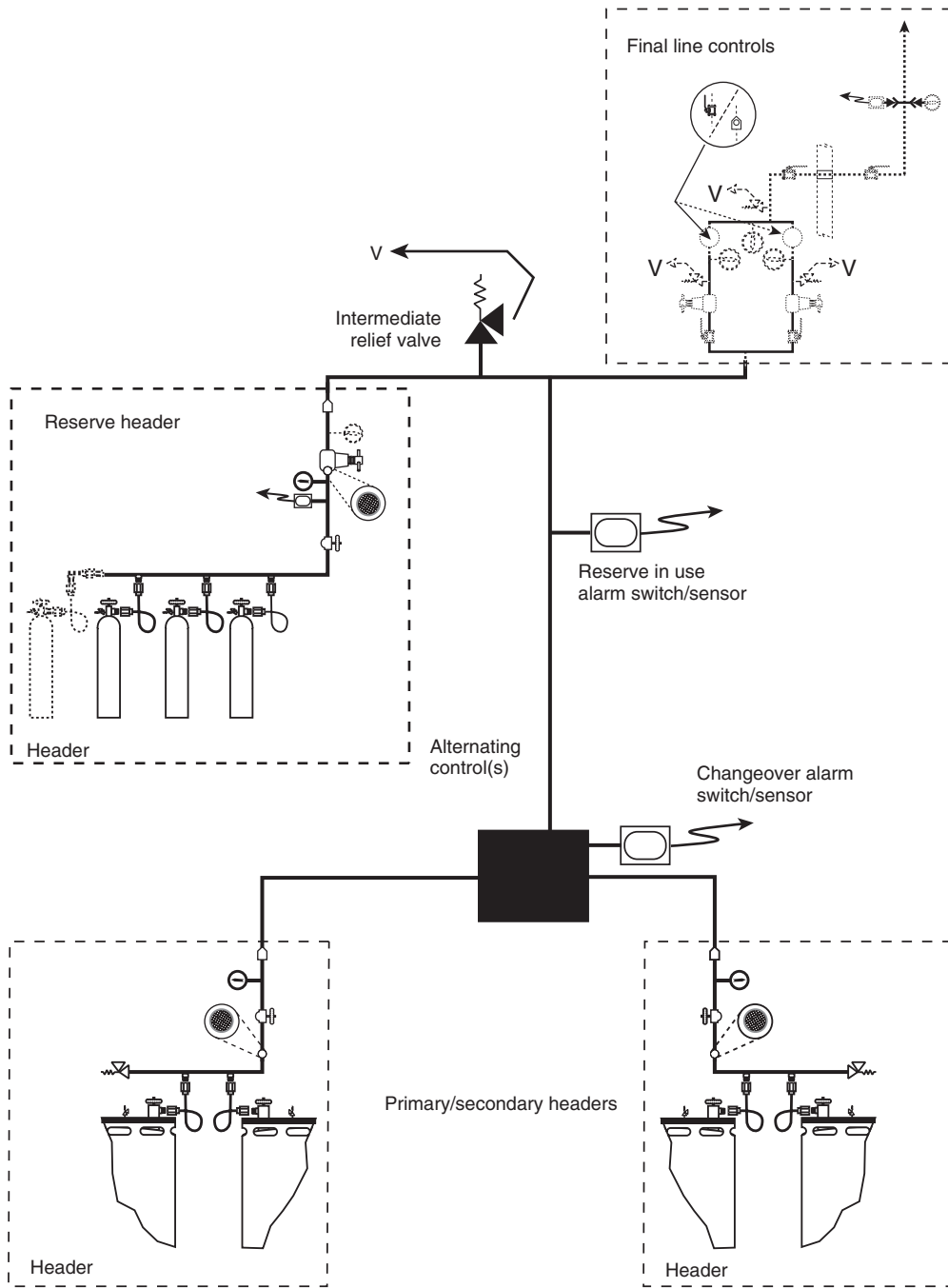


FIGURE A.5.1.3.5.11 Typical Source of Supply for Cryogenic Gas in Containers.

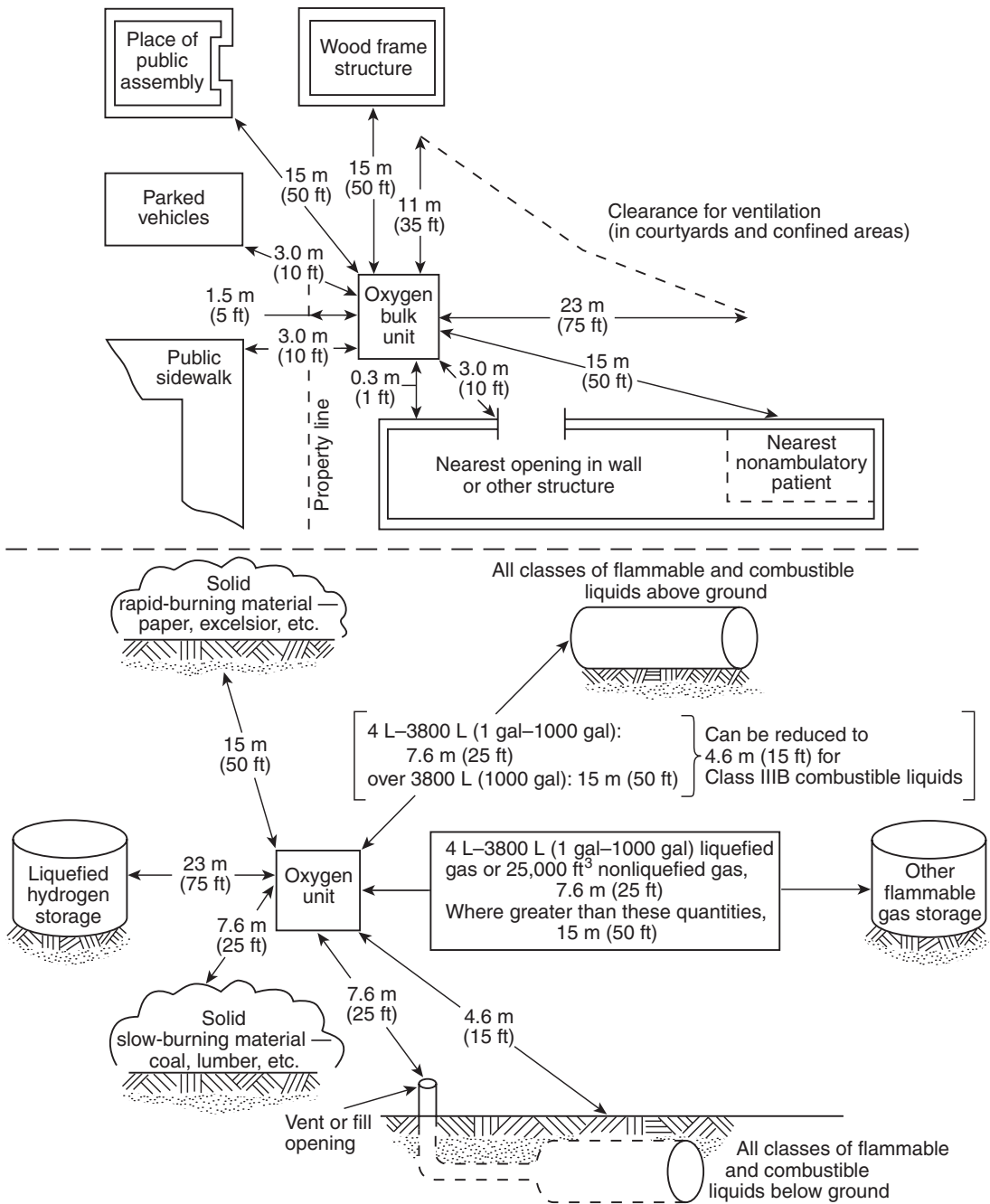


FIGURE A.5.1.3.5.12(a) Distance Between Bulk Oxygen Systems and Exposures.

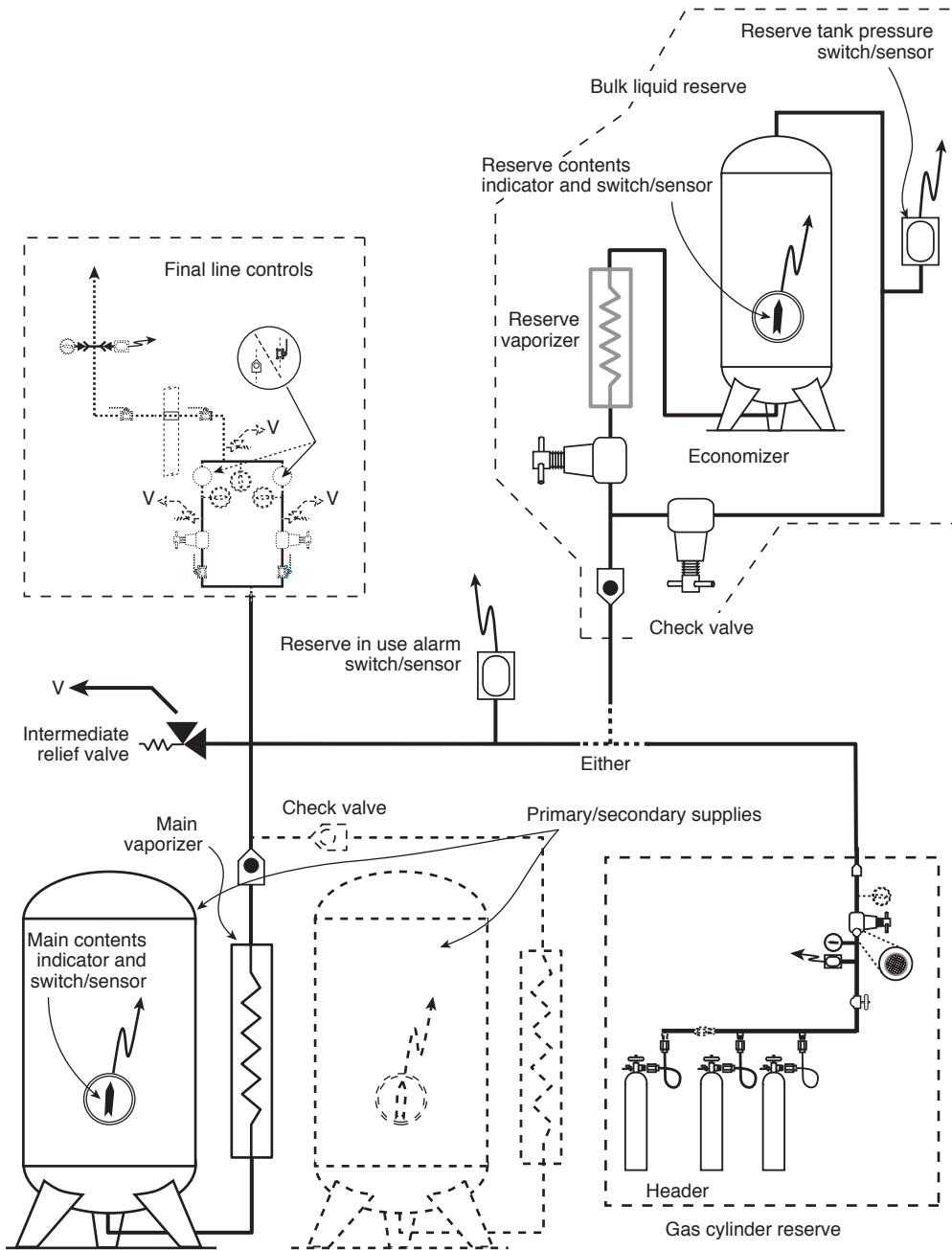
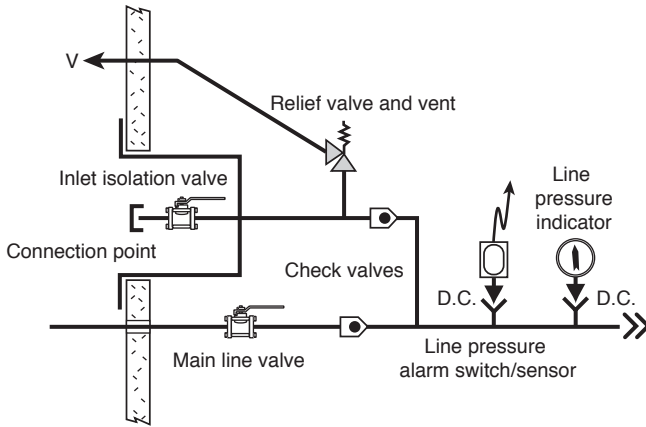


FIGURE A.5.1.3.5.12(b) Typical Source of Supply for Cryogenic Gas in Bulk.

**A.5.1.3.5.13** See Figure A.5.1.3.5.13.

If the relief valve on the emergency oxygen supply connection is moved downstream from the check valve in the emergency oxygen line, it should be connected to the system with a demand check fitting.



**FIGURE A.5.1.3.5.13** Emergency Oxygen Supply Connection.

**A.5.1.3.6** Air supplied from on-site compressor and associated air treatment systems (as opposed to medical air USP supplied in cylinders) that complies with the specified limits is considered medical air. Hydrocarbon carryover from the compressor into the pipeline distribution system could be detrimental to the safety of the end user and to the integrity of the piping system. Mixing of air and oxygen is a common clinical practice, and the hazards of fire are increased if the air is contaminated. Compliance with these limits is thus considered important to fire and patient safety. The quality of local ambient air should be determined prior to its selection for compressors and air treatment equipment. See Figure A.5.1.3.6.

**A.5.1.3.6.1** Supply systems for medical air using compressors draw air of the best available quality from a source of clean local ambient air; add no contaminants in the form of particulate matter, odor, or other gases; and dry, filter, regulate, and supply that air only via the medical air piping distribution system for use exclusively in the application of human respiration.

The utilization of an air treatment system is the joint responsibility of the system designer, the hospital clinical and engineering staffs, and the authority having jurisdiction. Different types of compressors have characteristics that affect the selection of the type of air treatment system. Some air treatment systems impose an additional load upon the compressors that has to be accounted for in the sizing of the system (usable capacity). The compressor duty cycle has to be chosen in accordance with the manufacturer's recommendation.

The type of air compressor and air condition at the intake will govern the type of filter provided for the air compressor supply system. All filters should be examined quarterly for the presence of liquids or excessive particulates and replaced according to the manufacturer's instructions.

One procedure for reaching a decision on the quality of the medical air is the following:

- (1) Test at the intake and at the sample connection valve.
- (2) If the two purities agree within the limits of accuracy of the test, the compressor system can be accepted.

- (3) If the air is found to exceed the values for medical compressed air as defined in 5.1.3.6.1, the facility can elect to install purification apparatus for the contaminants in question.

**A.5.1.3.6.2** It is the intent that the medical air piping distribution system support only the intended need for breathable air for such items as intermittent positive pressure breathing (IPPB) and long-term respiratory assistance needs, anesthesia machines, and so forth. The system is not intended to be used to provide engineering, maintenance, and equipment needs for general hospital support use. It is the intent that the life safety nature of the medical air be protected by a system dedicated solely for its specific use.

As a compressed air supply source, a medical air compressor should not be used to supply air for other purposes, because such use could increase service interruptions, reduce service life, and introduce additional opportunities for contamination.

**A.5.1.3.6.3** See Figure A.5.1.3.6.

**A.5.1.3.6.3.4(A)** Examples of 5.1.3.6.3.4(A)(1) are liquid ring and permanently sealed bearing compressors.

An example of 5.1.3.6.3.4(A)(2) is an extended head reciprocating compressor with an atmospheric vent between the compression chamber and the crankcase.

An example of 5.1.3.6.3.4(A)(3) is a rotating element compressor with the compression chamber being nonlubricated and separated from the lubricated gears by at least one shaft seal with an atmospheric vent on both sides. The vent on the lubricated side is provided with a gravity drain to atmosphere.

**A.5.1.3.6.3.9** Other functions can be added at the request of the facility, such as low water pressure, and so forth.

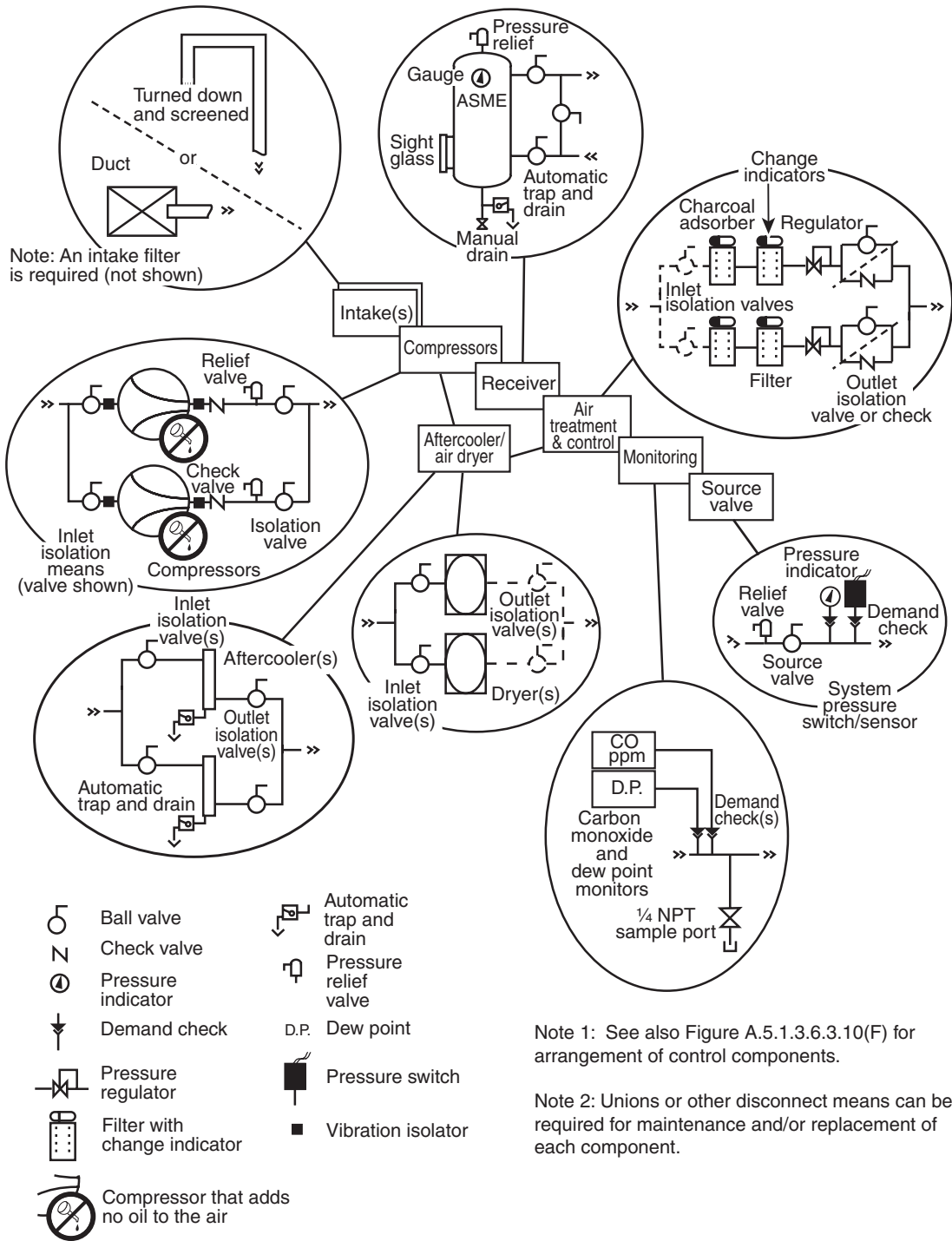
**A.5.1.3.6.3.10(D)** A typical example of valving the receiver is shown in Figure A.5.1.3.6.3.10(D).

**A.5.1.3.6.3.10(F)** The two configurations are equally acceptable. The components can be arranged in either of the arrangements shown in Figure A.5.1.3.6.3.10(F).

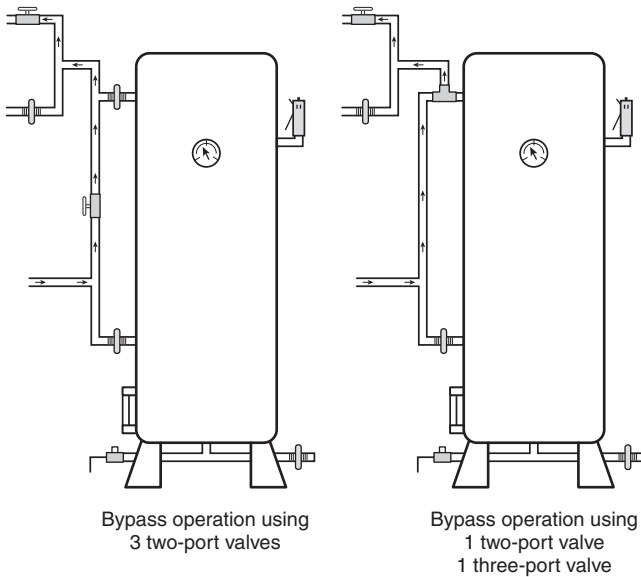
**A.5.1.3.6.3.15(A)(9)** The proportioning system should be monitored for conditions that can affect air quality during use or in the event of failure, based on the type of proportioning system design used in the system, including monitoring for the following systems and conditions:

- (1) Where proportioning systems used are configured with a primary proportioning system and a reserve medical air manifold per 5.1.3.5.10
- (2) Where proportioning systems used are configured with a primary proportioning system and a reserve proportioning system
- (3) Where proportioning systems used are configured with a primary proportioning system and a reserve medical air compressor per 5.1.3.5.3
- (4) Alarm at a predetermined set point, before the reserve supply begins to supply the system, indicating reserve supply in use
- (5) Alarm at a predetermined set point, before the reserve supply contents fall to one day's average supply, indicating reserve low

Water-in-receiver alarms are not required for a proportioning system.



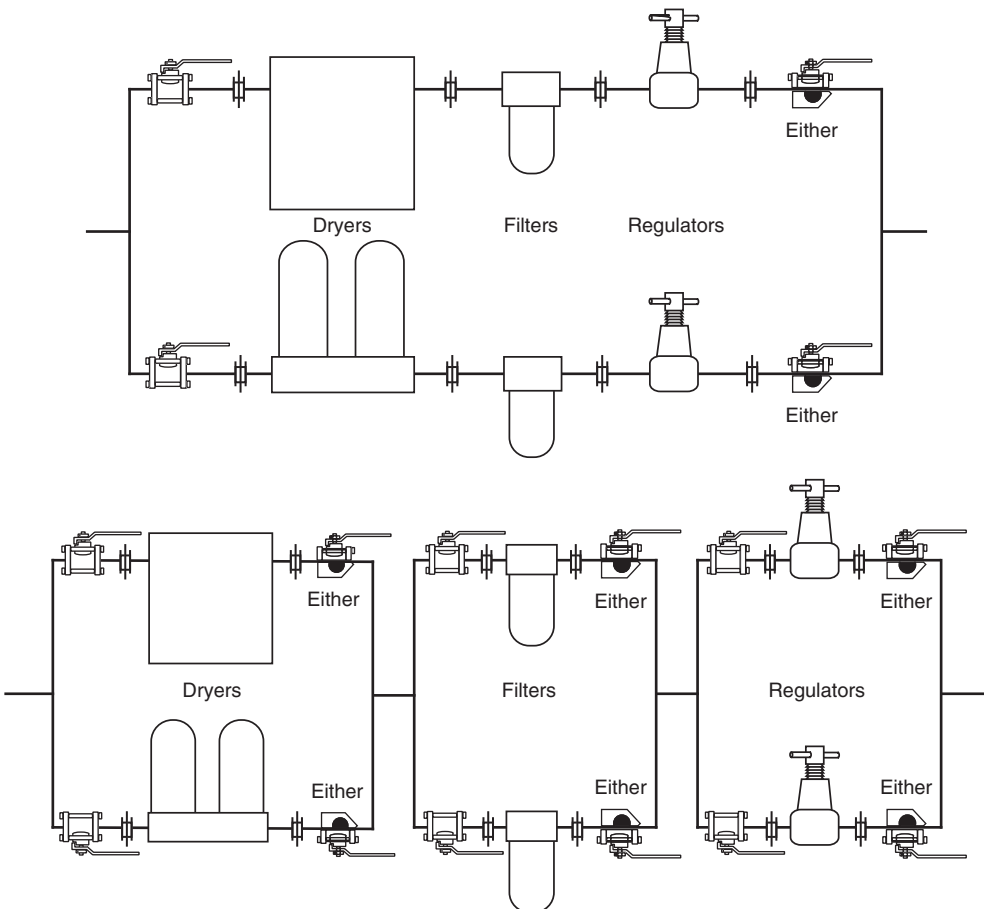
**FIGURE A.5.1.3.6 Elements of a Typical Duplex Medical Air Compressor Source System (Category 1 Gas Systems).**



**FIGURE A.5.1.3.6.3.10(D) Receiver Valving Arrangement.**

The engineering controls should include, as a minimum, the following:

- (1) Engineering controls should be in place when the sources of oxygen USP or nitrogen NF, or both, are the same sources as those supplying the oxygen USP or nitrogen NF pipelines, or both, for other uses within the health care facility, and the following should apply:
  - (a) In cases where a new supply system is installed, or in cases where one or more bulk supplies are used to supply the mixer, bulk systems and vaporizers should be sized for total peak demand flow, including peak demand flow to the mixer and any other areas of utilization.
  - (b) Operating limits should be established, at a minimum, for the oxygen and nitrogen source pressures, both high and low, and for the medical air oxygen concentration, both high and low, based upon USP specifications. A process upset can be defined as an excursion in the process windows established for oxygen and nitrogen source pressures or medical air oxygen concentration, or both. A means to detect excursion from these process limits and power failure should be provided.
  - (c) At least one dedicated valve or other control should be installed in the proportioning system and/or the line(s) between the oxygen and/or nitrogen supply system(s) and proportioning system. The purpose of the dedicated control(s) is to prevent the cross contamination



**FIGURE A.5.1.3.6.3.10(F) Alternate Valving Sequences for Line Controls in Medical Air.**

of the oxygen and nitrogen lines due to product back-flow as follows:

- i. The control(s) should be separate from the valve(s) or other device(s) used to control oxygen flow and nitrogen flow in normal operation.
  - ii. The control(s) should not cycle in normal operation.
  - iii. If installed in the line(s) between the oxygen or nitrogen supply system(s), or both, and proportioning system, upon activation of the control(s), an alarm should be sent to the facility. The control(s) cannot exist exclusively via the use of check valves.
- (d) In the event of a process upset, the dedicated control(s) should either positively isolate the supply of oxygen or nitrogen, or both, from the mixer, or the dedicated control(s) should reduce the mixer pressure to less than half of the minimum final line pressure values, each, for the oxygen and nitrogen lines. In the event of a process upset, the control(s) should operate. Manual reset should be required to restart the proportioning system.

in the event of failure, based on the type of proportioning system design used in the system, including the following situations:

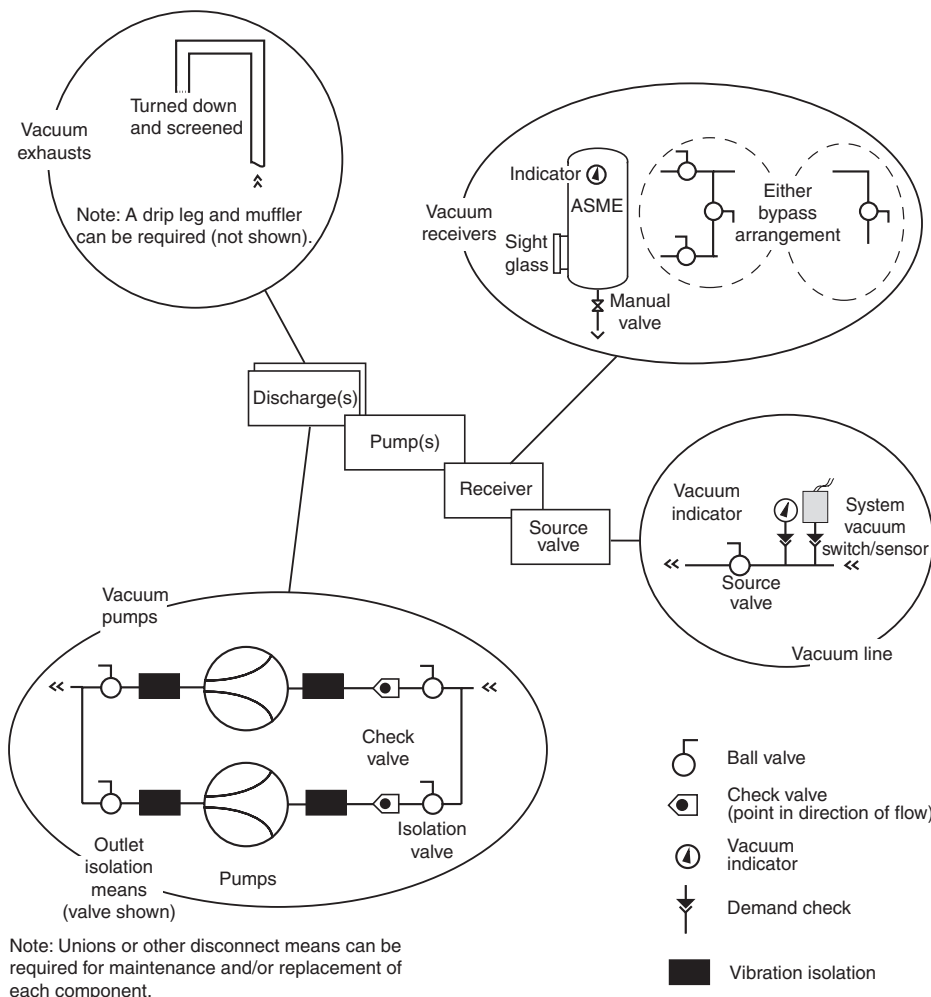
- (1) Where proportioning systems that are configured with a primary proportioning system and a reserve medical air manifold per 5.1.3.5.10 are used
- (2) Where proportioning systems that are configured with a primary proportioning system and a reserve proportioning system are used
- (3) Where proportioning systems that are configured with a primary proportioning system and a reserve medical air compressor per 5.1.3.5.10 are used
- (4) When proportioning systems are configured to alarm at a predetermined set point before the reserve supply begins to supply the system, indicating reserve supply in use
- (5) When proportioning systems are configured to alarm at a predetermined set point before the reserve supply contents fall to one day's average supply, indicating reserve low

Water-in-receiver alarms are not required for proportioning systems.

**A.5.1.3.7** See Figure A.5.1.3.7.

**A.5.1.3.8** A functioning WAGD system allows the facility to comply with occupational safety requirements by preventing the accumulation of waste anesthetic gases in the work environment.

**A.5.1.3.6.3.15(C)(9)** The proportioning system should be monitored for conditions that can affect air quality during use or



**FIGURE A.5.1.3.7** Elements of Typical Duplex Vacuum Source System (Category 1 Vacuum Systems).

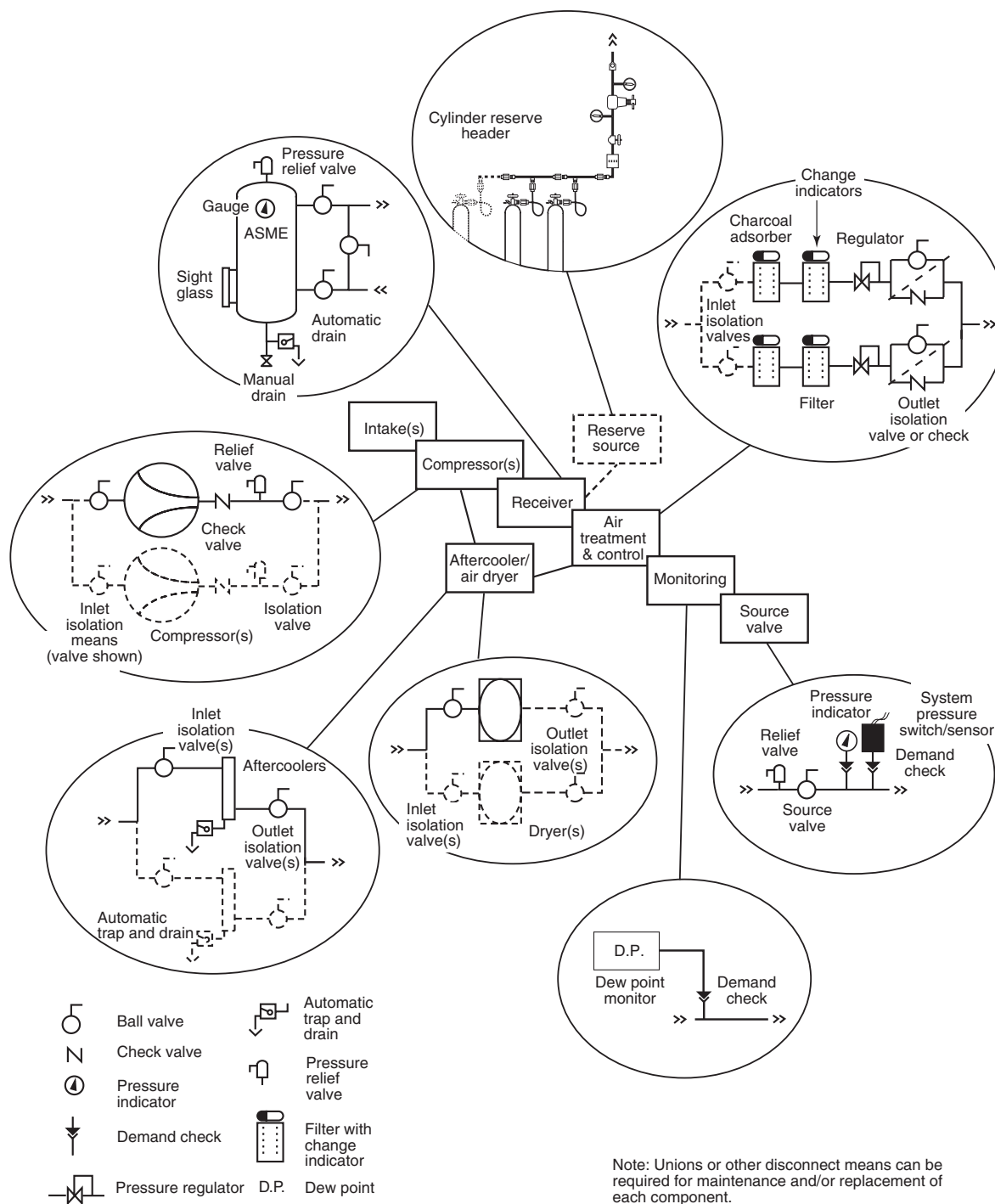
WAGD using an HVAC (heating, ventilation, and air-conditioning) system are not within the scope of Chapter 5.

Flammable and nonflammable gases are known to be incompatible with some seals and piping used in medical-surgical vacuum systems. If WAGD is to be included as part of the medical-surgical vacuum system, it should be recognized that this activity might cause deterioration of the vacuum system. The station inlet performance tests outlined in 5.1.12.3.10 are ex-

remely important in maintaining the integrity of the medical-surgical vacuum system, and they should be made at more frequent intervals if WAGD is included in the vacuum system.

**A.5.1.3.8.1** Interfaces are provided with overpressure, underpressure, overflow, and underflow compensation to ensure the breathing circuit is isolated from the WAGD system.

**A.5.1.3.9** See Figure A.5.1.3.9.



**FIGURE A.5.1.3.9** Elements of Typical Instrument Air Source.

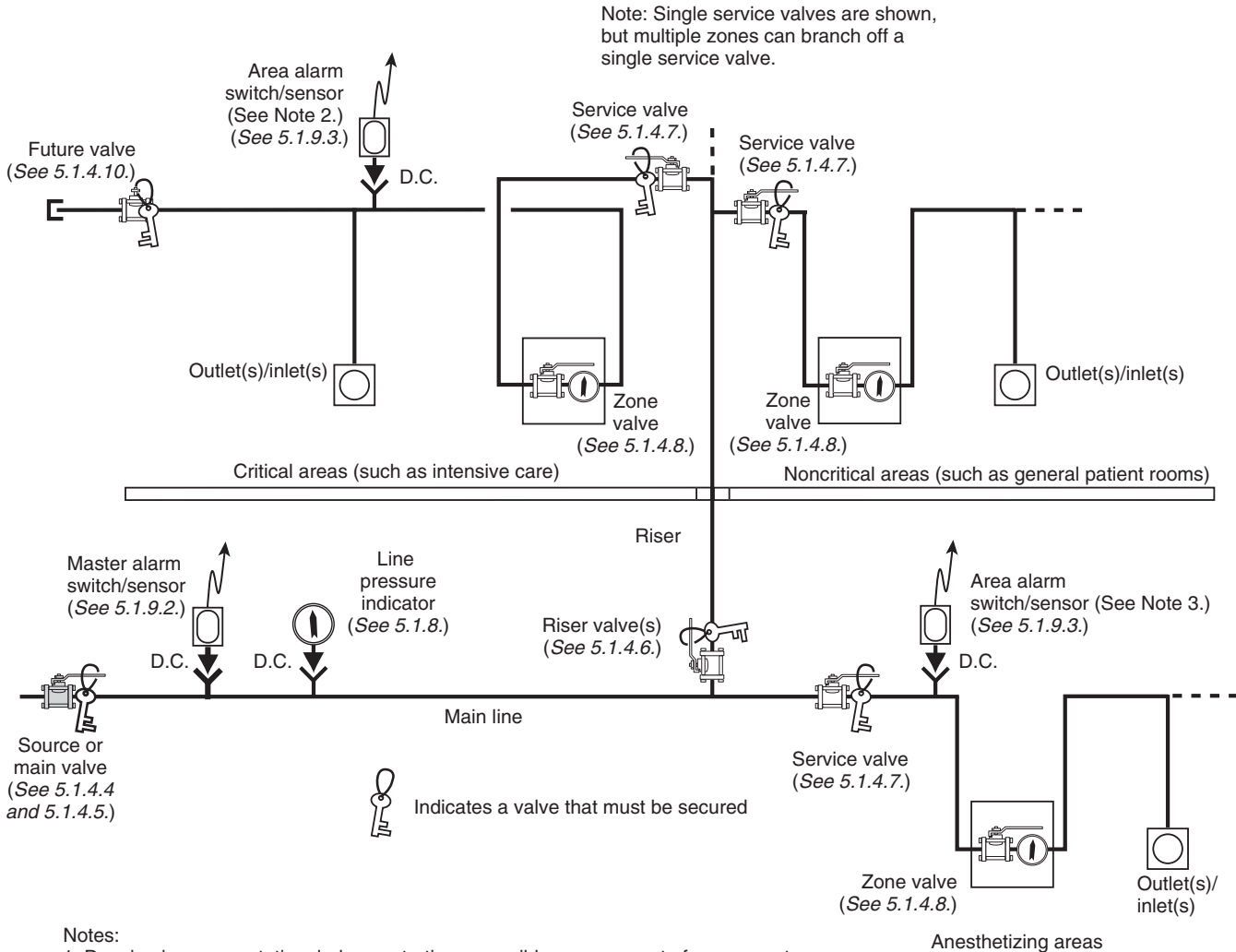


**A.5.1.3.9.6** Drawing intake air from outside in compliance with 5.1.3.6.3.12 is recommended.

**A.5.1.4** See Figure A.5.1.4.

Area alarms are required in critical care locations (e.g., intensive care units, coronary care units, angiography laboratories, cardiac catheterization laboratories, post-anesthesia recovery rooms, and emergency rooms) and anesthetizing locations (e.g., operating rooms and delivery rooms). Refer to definitions for these areas.

**A.5.1.4.5** The presence of a main line shutoff valve is optional where the source valve can equally or more effectively perform the same function. An example is a case where the source is within the building or just on the outside of the building and, therefore, there would be no great distance separating the two valves. A source that was physically separate from the building would require both valves to ensure the intervening piping could be controlled.



**Notes:**

1. Drawing is representational, demonstrating a possible arrangement of components required by the text. The diagram is not intended to imply a method, materials of construction, or more than one of many possible and equally compliant arrangements. Alternative arrangements are permitted if they meet the intent of the text.
2. Area alarms are required in critical care locations (examples might include intensive care units, coronary care units, angiography laboratories, cardiac catheterization laboratories, post-anesthesia recovery rooms, and emergency rooms) and anesthetizing locations (examples might include operating rooms and delivery rooms). Refer to definitions for these areas.
3. Locations for switches/sensors are not affected by the presence of service or in-line valves.

**FIGURE A.5.1.4** Arrangement of Pipeline Components.

**A.5.1.5** Station outlets/inlets should be located at an appropriate height above the floor to prevent physical damage to equipment attached to the outlet.

**A.5.1.6** Manufactured assembly examples include headwalls, columns, ceiling columns, ceiling-hung pendants, movable track systems, and so forth. See Figure A.5.1.6.

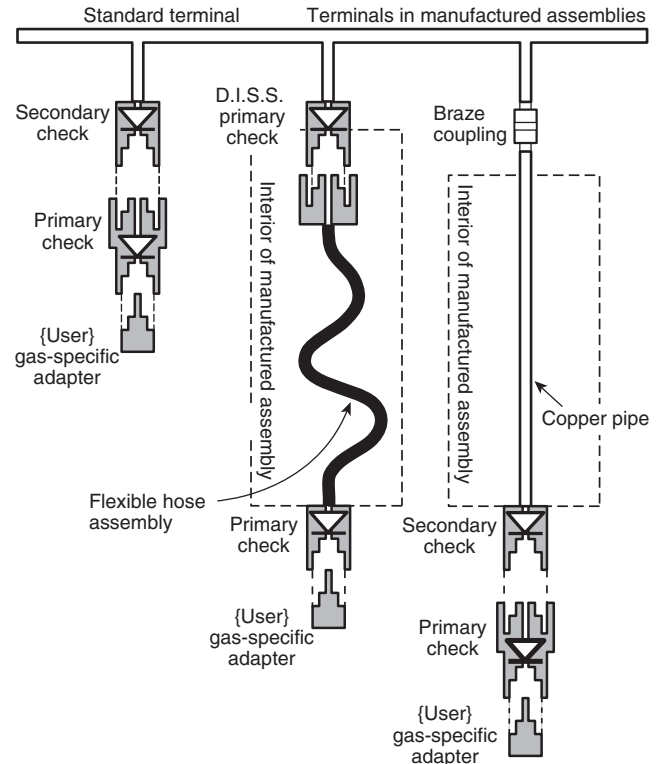
**A.5.1.7** It is the intent that surface-mounted medical gas rail systems would be permitted in individual patient rooms but would not be permitted to go directly through room walls to adjacent patient rooms. However, it is the intent to permit surface-mounted medical gas rails to be used in a given critical care area where there can be a partition separating certain patient care functions, essentially leaving the system within the given critical care area. As an example, two adjacent patient rooms outside of a critical care unit would not be permitted to have a surface-mounted medical gas rail interconnect between the two rooms through the wall. However, in a nursery where there might be one or two segregated areas for isolation, a medical gas rail system supplying more than one isolation room, but within the nursery area, would be permitted to be interconnected with the nursery system.

**A.5.1.7.9** Typical plating would be nickel plating over copper or brass per Federal Specification QQ-N290, Class I, Type 7.

**A.5.1.8.1.3** This gauge would therefore be suitable for any operating pressure of 690 kPa to 1380 kPa (100 psig to 200 psig).

**A.5.1.9** See Figure A.5.1.4.

**A.5.1.9.2** See Table A.5.1.9.2.



**FIGURE A.5.1.6** Terminals in Manufactured Assemblies.

**Table A.5.1.9.2** Requirements for Category 1 Master Alarms for Gas and Vacuum Systems

Alarm Condition	Manifold for Gas Cylinders Without Reserve (5.1.3.5.10)	Manifold for Cryogenic Liquid Cylinders with Reserve (5.1.3.5.11)	Cryogenic Bulk with Cryogenic Reserve (5.1.3.5.12)	Cryogenic Bulk with Cylinder Reserve (5.1.3.5.12)	Medical Air Compressors (5.1.3.6)	Instrument Air Compressors (5.1.3.9)	Medical-Surgical Vacuum Pumps (5.1.3.7)	WAGD Producers (5.1.3.7)
Nitrogen main line pressure high	5.1.9.2.4(7)							
Nitrogen main line pressure low	5.1.9.2.4(7)							
Nitrogen changeover to secondary supply	5.1.3.5.10.6 5.1.9.2.4(1)							
Carbon dioxide main line pressure high	5.1.9.2.4(7)							
Carbon dioxide main line pressure low	5.1.9.2.4(7)							
Carbon dioxide changeover to secondary supply	5.1.3.5.10.6 5.1.9.2.4(1)							
Medical air main line pressure high	5.1.9.2.4(7)				5.1.9.2.4(7)			
Medical air main line pressure low	5.1.9.2.4(7)				5.1.9.2.4(7)			
Medical air changeover to secondary supply	5.1.3.4.5.6 5.1.9.2.4(1)							
Medical air dew point high					5.1.3.6.3.14(1) 5.1.9.2.4(10)			
Oxygen main line pressure high	5.1.9.2.4(7)	5.1.9.2.4(7)	5.1.9.2.4(7)	5.1.9.2.4(7)				
Oxygen main line pressure low	5.1.9.2.4(7)	5.1.9.2.4(7)	5.1.9.2.4(7)	5.1.9.2.4(7)				
Oxygen changeover to secondary supply	5.1.3.5.10.6 5.1.9.2.4(1)	5.1.3.5.11.9 5.1.9.2.4(1)	5.1.9.2.4(1)	5.1.9.2.4(1)				
Oxygen main supply less than 1 day (low contents)			5.1.9.2.4(2)	5.1.9.2.4(2)				
Oxygen reserve in use		5.1.3.5.11.9(3) 5.1.3.5.14.5 5.1.9.2.4(3)	5.1.9.2.4(3)	5.1.3.5.14.5 5.1.9.2.4(3)				

(continues)

**Table A.5.1.9.2** *Continued*

Alarm Condition	Manifold for Gas Cylinders Without Reserve (5.1.3.4.10)	Manifold for Cryogenic Liquid Cylinders with Reserve (5.1.3.4.12)	Cryogenic Bulk with Cryogenic Reserve (5.1.3.4.13)	Cryogenic Bulk with Cylinder Reserve (5.1.3.4.13)	Medical Air Compressors (5.1.3.5)	Instrument Air Compressors (5.1.3.8)	Medical-Surgical Vacuum Pumps (5.1.3.6)	WAGD Producers (5.1.3.7)
Oxygen reserve supply less than 1 day (low contents)		5.1.3.5.11.9(4) 5.1.9.2.4(5)	5.1.9.2.4(5)					
Oxygen reserve pressure low (not functional)			5.1.9.2.4(6)					
Nitrous oxide main line pressure high	5.1.9.2.4(7)	5.1.9.2.4(7)	5.1.9.2.4(7)	5.1.9.2.4(7)				
Nitrous oxide main line pressure low	5.1.9.2.4(7)	5.1.9.2.4(7)	5.1.9.2.4(7)	5.1.9.2.4(7)				
Nitrous oxide changeover to secondary supply	5.1.3.5.10.6 5.1.9.2.4(1)	5.1.3.5.11.9(1) 5.1.9.2.4(1)	5.1.9.2.4(1)	5.1.9.2.4(1)				
Nitrous oxide main supply less than 1 day (low contents)			5.1.9.2.4(2)	5.1.9.2.4(2)				
Nitrous oxide reserve in use		5.1.3.5.14.5 5.1.9.2.4(3)	5.1.3.5.11.9(3) 5.1.9.2.4(3)	5.1.3.5.11.9(3) 5.1.3.5.14.5 5.1.9.2.4(3)				
Nitrous oxide reserve supply less than 1 day (low contents)		5.1.3.5.12.4(3) 5.1.9.2.4(5)	5.1.9.2.4(5)					
Nitrous oxide reserve pressure low (not functional)			5.1.9.2.4(6)					
Medical-surgical main line vacuum low							5.1.9.2.4(8)	
WAGD main line vacuum low								5.1.9.2.4(11)
Local alarm					5.1.3.6.3.13 5.1.9.2.4(9) 5.1.9.5.2	5.1.3.9.10 5.1.9.2.4(9) 5.1.9.5.2	5.1.3.7.8 5.1.9.2.4(9) 5.1.9.5.2	5.1.3.8.4.1 5.1.9.2.4(9) 5.1.9.5.2
Instrument air main line pressure high						5.1.9.2.4(7)		
Instrument air main line pressure low						5.1.9.2.4(7)		
Instrument air dew point high						5.1.3.9.10.1 5.1.9.2.4(12) 5.1.3.9.10.2(1)		
Instrument air cylinder reserve in use (if provided)						5.1.3.9.10.2(1)		
Instrument air cylinder reserve less than 1 hour supply						5.1.3.9.10.2(2)		

**A.5.1.9.3** See Table A.5.1.9.3.

**A.5.1.9.3(2)** Examples of critical care areas include post-anesthesia recovery, intensive care units, and emergency departments.

**A.5.1.9.3.1** Area alarm panels should be placed in a location that will most closely fulfill the following criteria (recognizing that no existing location might fulfill all criteria):

- (1) Near or within the location where the staff will most often be present (e.g., a staff base, a nurses' station)
- (2) Where the audible alert will best carry throughout the unit being surveilled
- (3) Where the panel is visible from the largest number of rooms, beds, or stations within the zone
- (4) Where visualization of the panel will not be blocked (e.g., by cabinet doors, carts, room doors, curtains, supplies)
- (5) At a height above the floor at which the panel can be comfortably viewed and at which the mute button can be conveniently accessed

**A.5.1.9.3.4(1)** This signal is intended to provide immediate warning for loss of, or increase in, system pressure for each individual vital life support and critical care area.

**A.5.1.9.3.4(2)** This signal is intended to provide immediate warning for loss of, or increase in, system pressure for all anesthetizing locations supplied from a single branch line — not for each individual operating or delivery room.

**Table A.5.1.9.3** Requirements for Category 1 Area Alarms

Alarm Condition	Requirement Location
High line pressure (for each gas piped to the area)	5.1.9.3
	5.1.9.3.1
	5.1.9.3.2 5.1.9.3.4
Low line pressure (for each gas piped to the area)	5.1.9.3
	5.1.9.3.1
	5.1.9.3.2 5.1.9.3.4
Low medical-surgical vacuum (if piped to the area)	5.1.9.3
	5.1.9.3.1
	5.1.9.3.3
	5.1.9.3.4
Low WAGD vacuum (if piped to the area)	5.1.9.3
	5.1.9.3.1
	5.1.9.3.3
	5.1.9.3.4

**A.5.1.9.5** Activation of any of the warning signals should immediately be reported to the department of the facility responsible for the medical gas piping system involved. If the medical gas is supplied from a bulk supply system, the owner or the organization responsible for the operation and maintenance of that system, usually the supplier, should also be notified. As much detail as possible should be provided. See Table A.5.1.9.5.

**A.5.1.10.1.4** Operation of piped medical gas systems at gauge pressures in excess of 1275 kPa (185 psi) involves certain restrictions because of the limitations in materials.

**A.5.1.10.3.1** A distinction is made between deep-socket solder-joint fittings (ASME B16.22, *Wrought Copper and Copper Alloy Solder Joint Pressure Fitting*) and those having shallow sockets for brazing (ANSI/ASME B16.50, *Wrought Copper and Copper Alloy Braze Joint Pressure Fitting*). The use of shallow-socket brazing fittings improves the quality of the brazement without decreasing its strength, particularly in larger sizes, which are difficult to heat. See Table A.5.1.10.3.1 for socket depths conforming to ANSI/ASME B16.50. The installer can use ANSI/ASME B16.50 fittings (if available) or have the sockets on ASME B16.22 fittings cut down to ASME B16.50 depths. Where shallow-socket fittings are used for the medical gas piping, care should be taken to avoid their use in other piping systems where joints could be soldered instead of brazed.

**A.5.1.10.4.5** The intent is to provide an oxygen-free atmosphere within the tubing and to prevent the formation of copper oxide scale during brazing. This is accomplished by filling the piping with a low-volume flow of low pressure inert gas.

**A.5.1.10.4.5.12** This is to ensure a quality joint and to prevent the formation of copper oxide on the inside and outside surfaces of the joint.

**A.5.1.10.5.1.5** Gas mixtures are commonly used in GTAW autogenous fusion welding. The identification of a gas mixture as “75He 25Ar” is a common industry term to define a commercially available grade from gas suppliers. If test welding results lead to questions about the mixture percentage or gas quality, another bottle should be substituted and test welds performed.

**A.5.1.10.8(3)** One example of this type of tape is Teflon™.

**A.5.1.11** It is recommended that the facility’s normal operating pressure of nitrous oxide be initially set and continually maintained at least 34.5 kPa (5 psig) below the normal operating pressures of the oxygen and medical air.

Piping systems that are connected though blending devices are in effect cross-connected through the device. In the rare event of a failure of the safeties inside the equipment, the possibility of having the gases flow across the device exists. When the device is an anesthesia machine, and one of the gases is nitrous oxide, a pressure in the nitrous oxide pipeline greater than the pressure in the medical air or oxygen system opens the possibility of nitrous oxide flowing into the other pipelines. A patient could then receive a lethal quantity of nitrous oxide from a labeled and indexed medical air or oxygen outlet. Adjusting the pressure as recommended can reduce the likelihood of the causative equipment failure and also reduce the severity of the problem in the event it does occur.

**A.5.1.12** All testing should be completed before putting a new piping system, or an addition to an existing system, into service. Test procedures and the results of all tests should be made part of the permanent records of the facility of which the piping system forms a part. They should show the room and area designations, dates of the tests, and name(s) of the person(s) conducting the tests.

**Table A.5.1.9.5 Requirements for Category 1 Local Alarms**

Alarm Condition	Medical Air Compressors					
	Oilless (Sealed Bearing) 5.1.3.6.3.4(A)(1)	Oil-Free (Separated) 5.1.3.6.3.4(A)(2)	Liquid Ring (Water-Sealed) 5.1.3.6.3.4(A)(1)	Instrument Air Compressors	Medical-Surgical Vacuum Pumps	WAGD Producers
Backup (lag) compressor in operation	5.1.3.6.3.13(E) 5.1.9.5.4(1)	5.1.3.6.3.13(E) 5.1.9.5.4(1)	5.1.3.6.3.13(E) 5.1.9.5.4(1)			
Backup (lag) medical-surgical vacuum pump in operation					5.1.3.7.8 5.1.9.5.4(4)	
Backup (lag) WAGD producer in operation						5.1.3.8.4.2 5.1.9.5.4(5)
Backup (lag) instrument air compressor in operation				5.1.3.9.10.1(1) 5.1.9.5.4(1)		
Carbon monoxide high	5.1.3.6.3.14(2) 5.1.9.5.1(2)	5.1.3.6.3.14(2) 5.1.9.5.1(2)	5.1.3.6.3.14(2) 5.1.9.5.1(2)			
High discharge air temperature	5.1.3.6.3.13(C) 5.1.9.5.4(9)	5.1.3.6.3.13(D)(1) 5.1.9.5.4(9)				
High water in receiver	5.1.3.6.3.13(A) 5.1.9.5.4(7)	5.1.3.6.3.13(A) 5.1.9.5.4(7)	5.1.3.6.3.13(A) 5.1.9.5.4(7)			
High water in separator			5.1.3.6.3.13(B) 5.1.9.5.4(8)			
Medical air dew point high	5.1.3.5.15(1) 5.1.9.5.4(3)	5.1.3.6.3.14(1) 5.1.9.5.4(3)	5.1.3.6.3.14(1) 5.1.9.5.4(3)			
Instrument air dew point high				5.1.3.9.10.1(2) 5.1.9.5.4(6)		

**Table A.5.1.10.3.1 Socket Depths for ASME B16.50 Brazing Fittings**

Tube Size (in.)	Socket Depth (in.)
¼ (⅜ O.D.)	0.17
⅜ (½ O.D.)	0.2
½ (⅝ O.D.)	0.22
¾ (7⁄8 O.D.)	0.25
1 (1½ O.D.)	0.28
1¼ (1⅝ O.D.)	0.31
1½ (1⅞ O.D.)	0.34
2 (2½ O.D.)	0.40
2½ (2⅝ O.D.)	0.47
3 (3⅝ O.D.)	0.53
4 (4⅝ O.D.)	0.64
5 (5⅝ O.D.)	0.73
6 (6⅝ O.D.)	0.83

**A.5.1.12.2.3.5** Ammonia is known to cause stress cracking in copper and its alloys.

**A.5.1.12.2.6.5** The effect of temperature changes on the pressure of a confined gas is based on the Ideal Gas Law. The final absolute pressure (P2a) equals the initial absolute pressure (P1a) times the final absolute temperature (T2a), divided by the initial absolute temperature (T1a). The relationship is the same for nitrogen, nitrous oxide, oxygen, and compressed air.

Absolute pressure is the gauge pressure reading plus the absolute atmospheric pressure. See Table A.5.1.12.2.6.5 for the absolute atmospheric pressures for elevations at and above sea level.

Absolute temperature K (°R) is the temperature gauge reading °C (°F) plus the absolute zero temperature 273°C (460°F).

Examples of pressure test data at sea level in SI and IP units follow.

The initial test pressure is 415 kPag (60 psig) at 27°C (80°F). A temperature decrease to 18°C (65°F) will cause the test pressure to drop to 400 kPag (57.9 psig).

$$P1g = 415 \text{ kPag}, T1g = 27^\circ\text{C}, T2g = 18^\circ\text{C}, P1g = 60 \text{ psig}, T1g = 80^\circ\text{F}, T2g = 65^\circ\text{F}$$

$$\begin{aligned} P1a &= 415 + 101 = 516 \text{ kPa} & P1a &= 60 + 14.7 = 74.7 \text{ psia} \\ T1a &= 27 + 273 = 300\text{K} & T1a &= 80 + 460 = 540^\circ\text{R} \\ T2a &= 18 + 273 = 291\text{K} & T2a &= 65 + 460 = 525^\circ\text{R} \\ P2a &= 516 \times 291/300 = & P2a &= 74.7 \times 525/540 = \\ & 501 \text{ kPa} & & 72.6 \text{ psia} \\ P2g &= 501 - 101 = 400 \text{ kPag} & P2g &= 72.6 - 14.7 = 57.9 \text{ psig} \end{aligned}$$

**A.5.1.12.2.7.5** The effect of temperature changes on the vacuum of a confined gas is based on the Ideal Gas Law. The final absolute vacuum (V2a) equals the initial absolute vacuum (V1a) times the final absolute temperature (T2a), divided by the initial absolute temperature (T1a).

Absolute vacuum is the absolute zero pressure 101 kPa (30 inHg) less the vacuum reading below atmospheric. See Table A.5.1.12.2.6.5 for the absolute atmospheric pressures for elevations at and above sea level.

Absolute temperature K (°R) is the temperature gauge reading °C (°F) plus the absolute zero temperature 273°C (460°F).

Examples of vacuum test data at sea level in SI and IP units follow.

The initial test vacuum is 54 kPa or 16 inHg at 18°C (65°F). A temperature increase to 27°C (80°F) will cause the test vacuum to decrease to 52.5 kPa (15.6 inHg).

$$V1g = 54 \text{ kPa}, T1g = 18^\circ\text{C}, T2g = 27^\circ\text{C}, V1g = 16 \text{ inHg}, T1g = 65^\circ\text{F}, T2g = 80^\circ\text{F}$$

$$\begin{aligned} V1a &= 101 - 54 = +47 \text{ kPaV} & V1a &= 30 - 16 = +14 \text{ inHgV} \\ T1a &= 18 + 273 = 291\text{K} & T1a &= 65 + 460 = 525^\circ\text{R} \\ T2a &= 27 + 273 = 300\text{K} & T2a &= 80 + 460 = 540^\circ\text{R} \\ V2a &= 47 \times 300/291 = +48.5 & V2a &= 14 \times 540/525 = \\ & \text{kPaV} & & +14.4 \text{ inHgV} \\ V2g &= 101 - 48.5 = 52.5 \text{ kPa} & V2g &= 30 - 14.4 = 15.6 \text{ inHg} \end{aligned}$$

**A.5.1.12.3.2** This is the final pressure test of the completely installed system and is intended to locate any leaks that would be more likely to occur at lower pressure (e.g., leaks in station outlet valve seals).

**Table A.5.1.12.2.6.5 Pressure Corrections for Elevation**

Elevation (ft)	Absolute Atmospheric Pressure			
	kPa	psia	mmHg	inHg
0	101.33	14.70	760.0	29.92
500	99.49	14.43	746.3	29.38
1000	97.63	14.16	733.0	28.86
1500	95.91	13.91	719.6	28.33
2000	94.19	13.66	706.6	27.82
2500	92.46	13.41	693.9	27.32
3000	90.81	13.17	681.2	26.82
3500	89.15	12.93	668.8	26.33
4000	87.49	12.69	656.3	25.84
4500	85.91	12.46	644.4	25.37
5000	84.33	12.23	632.5	24.90

**A.5.1.12.3.8** The detector used for total hydrocarbons is calibrated with a gas that has a known quantity of methane. When a sample is run with this calibrated detector, the result will be total hydrocarbons as methane. Since methane is the one hydrocarbon that does not interact with the body and is present in all air and most oxygen, the actual amount of methane in the sample is subtracted from the total hydrocarbon result to give total non-methane hydrocarbons.

**A.5.1.12.3.11(3)** The committee recognizes that current clinical practice is to use analyzers that might not be able to analyze oxygen to current USP requirements of 99 percent and that these analyzers frequently have an error of up to 3 percent.

**A.5.1.13.1** Support gas systems are subject to the same hazards as are present in any piped medical gas system, with the additional hazard of operating at higher pressures.

**A.5.1.14** All cylinders containing compressed gases, such as anesthetic gases, oxygen, or other gases used for medicinal purposes, whether these gases are flammable or not, should comply with the specifications and be maintained in accordance with regulations of the U.S. Department of Transportation.

Cylinder and container temperatures greater than 52°C (125°F) can result in excessive pressure increase. Pressure relief devices are sensitive to temperature and pressure. When relief devices actuate, contents are discharged.

**A.5.1.14.1.1** Piping systems for the distribution of flammable gases (e.g., hydrogen, acetylene, natural gas) are outside the scope of this chapter.

**A.5.1.14.1.3** Vacuum systems from station inlets to the exhaust discharge should be considered contaminated unless proven otherwise. Methods exist to disinfect the system or portions thereof.

Clogging of regulators, for example, with lint, debris, or dried body fluids, reduces vacuum system performance.

**A.5.1.14.1.4** Other examples of prohibited use of medical-surgical vacuum would be scope cleaning, decontamination, and laser plume.

**A.5.1.14.2.1** The facility should retain a written or an electronic copy of all findings and any corrections performed.

**A.5.1.14.2.2.2** In addition to the minimum inspection and testing in 5.1.14, facilities should consider annually inspecting equipment and procedures and correcting any deficiencies.

**A.5.1.14.2.3.1(1)** Additional inspections for medical air sources include the following:

- (1) Aftercoolers (condition, operation of automatic drains)
- (2) Operating pressures (cut-in, cut-out, and control pressures)
- (3) Electrical operation
- (4) Receiver elements (auto drain, manual drain, sight glass, pressure gauge)
- (5) Pressure regulators (condition)
- (6) Dryer (operation, outlet dew point, condition, housekeeping)
- (7) Dew point calibration
- (8) Housekeeping around compressors

**A.5.1.14.2.3.1(2)** Additional inspections for medical vacuum sources and WAGD sources include the following:

- (1) Operating vacuum (cut-in, cut-out, and control pressures)
- (2) Electrical operation

- (3) Receiver elements (manual drain, sight glass, vacuum gauge)
- (4) Housekeeping around pump

**A.5.1.14.2.3.1(4)** Additional inspections for instrument air sources include the following:

- (1) Aftercoolers (condition, operation of drains)
- (2) Operating pressures (cut in, cut out, and control pressures)
- (3) Electrical operation
- (4) Receiver elements (auto drain, manual drain, sight glass, pressure gauge)
- (5) Pressure regulators (condition)
- (6) Housekeeping around compressors

**A.5.1.14.2.3.1(5)** Additional inspections for manifold sources include the following:

- (1) Cylinder leads (condition)
- (2) Cascade (switching from one header to another)
- (3) Source valve (labeling)
- (4) Relief valves (discharge location and condition)
- (5) Leaks
- (6) Security (door or gate locks and signage)
- (7) Housekeeping around manifolds

**A.5.1.14.2.3.1(8)** Additional inspections for zone valves include the following:

- (1) Locations (relationship to terminals controlled)
- (2) Leaks
- (3) Labeling
- (4) Housekeeping around alarm

**A.5.1.14.2.3.1(9)** Additional inspections for alarms include the following:

- (1) Dew point monitor (operation and calibration)
- (2) Carbon monoxide monitor (operation and calibration)
- (3) All local alarms on medical air, vacuum, WAGD, manifolds, medical support gas sources (verify presence of required alarms, perform electrical test, test lag alarm)
- (4) Locations (visible to staff)
- (5) Housekeeping around alarms

**A.5.1.14.2.3.1(11)** An additional inspection for station outlets/inlets is a general condition (noninterchangeable indexing).

**A.5.1.15** Medical gas and vacuum systems should be surveyed at least annually for the items that follow and deficient items corrected. Survey of medical air and instrument air sources should include, but not be limited to, the following:

- (1) Dew point monitor (operation and calibration)
- (2) Carbon monoxide monitor (medical air only) (operation and calibration)
- (3) Aftercoolers (condition, operation of drains)
- (4) Operating pressures (cut-in, cut-out, and control pressures)
- (5) All local alarms (verify presence of required alarms, perform electrical test, test lag alarm)
- (6) Receiver elements (auto drain, manual drain, sight glass, pressure gauge)
- (7) Filters (condition)
- (8) Pressure regulators (condition, output pressure)
- (9) Source valve (labeling)
- (10) Intake (location and condition)
- (11) Housekeeping around compressors

Survey of the medical vacuum and the WAGD source(s) should include, but not be limited to, the following:

- (1) Operating vacuum (cut-in, cut-out, and control pressures)
- (2) All local alarms (verify presence of required alarms, perform electrical test, test lag alarm)
- (3) Receiver elements (manual drain, sight glass, vacuum gauge)
- (4) Source valve (labeling)
- (5) Exhaust (location and condition)
- (6) Housekeeping around pump

Survey of the medical gas manifold source(s) should include, but not be limited to, the following:

- (1) Number of cylinders (damaged connectors)
- (2) Cylinder leads (condition)
- (3) Cascade (switching from one header to another)
- (4) All local alarms (verify presence of required alarms, perform electrical test, test all alarms)
- (5) Source valve (labeling)
- (6) Relief valves (discharge location and condition)
- (7) Leaks
- (8) Security (door or gate locks and signage)
- (9) Ventilation (general operation, housekeeping)
- (10) Housekeeping around manifolds

Survey of medical gas area alarms should include, but not be limited to, the following:

- (1) Locations (visible to staff)
- (2) Signals (audible and visual, use test function)
- (3) Activation at low pressure
- (4) Housekeeping around alarm

Survey of medical gas master alarms should include, but not be limited to, the following:

- (1) Locations (visible to appropriate staff)
- (2) Signals (audible and visual, use test function)
- (3) Activation at low pressure
- (4) Housekeeping around alarm

Survey of zone valves should include, but not be limited to, the following:

- (1) Locations (relationship to terminals controlled)
- (2) Leaks
- (3) Labeling
- (4) Housekeeping around alarm

Survey of medical gas outlet/inlets should include, but not be limited to, the following:

- (1) Flow and function
- (2) Latching/delatching
- (3) Leaks
- (4) General condition (noninterchangeable indexing)

The facility should retain a written or an electronic copy of all findings and any corrections performed.

**A.5.2.1** Section 5.1 covers requirements for Category 1 piped gas and vacuum systems; Section 5.2 covers Category 2 piped gas and vacuum systems; and Section 5.3 covers Category 3 piped gas and vacuum systems. Laboratory systems are no longer covered by Chapter 5 (2002 edition).

**A.5.2.14** Medical gas and vacuum systems should be surveyed at least annually for the items that follow and deficient items corrected. Survey of medical air and instrument air sources should include, but not be limited to, the following:

- (1) Dew point monitor (operation and calibration)
- (2) Carbon monoxide monitor (medical air only) (operation and calibration)

- (3) Aftercoolers (condition, operation of drains)
- (4) Operating pressures (cut-in, cut-out, and control pressures)
- (5) All local alarms (verify presence of required alarms, perform electrical test, test lag alarm)
- (6) Receiver elements (auto drain, manual drain, sight glass, pressure gauge)
- (7) Filters (condition)
- (8) Pressure regulators (condition, output pressure)
- (9) Source valve (labeling)
- (10) Intake (location and condition)
- (11) Housekeeping around compressors

Survey of the medical vacuum and the WAGD source(s) should include, but not be limited to, the following:

- (1) Operating vacuum (cut-in, cut-out, and control pressures)
- (2) All local alarms (verify presence of required alarms, perform electrical test, test lag alarm)
- (3) Receiver elements (manual drain, sight glass, vacuum gauge)
- (4) Source valve (labeling)
- (5) Exhaust (location and condition)
- (6) Housekeeping around pump

Survey of the medical gas manifold source(s) should include, but not be limited to, the following:

- (1) Number of cylinders (damaged connectors)
- (2) Cylinder leads (condition)
- (3) Cascade (switching from one header to another)
- (4) All local alarms (verify presence of required alarms, perform electrical test, test all alarms)
- (5) Source valve (labeling)
- (6) Relief valves (discharge location and condition)
- (7) Leaks
- (8) Security (door or gate locks and signage)
- (9) Ventilation (general operation, housekeeping)
- (10) Housekeeping around manifolds

Survey of medical gas area alarms should include, but not be limited to, the following:

- (1) Locations (visible to staff)
- (2) Signals (audible and visual, use test function)
- (3) Activation at low pressure
- (4) Housekeeping around alarm

Survey of medical gas master alarms should include, but not be limited to, the following:

- (1) Locations (visible to appropriate staff)
- (2) Signals (audible and visual, use test function)
- (3) Activation at low pressure
- (4) Housekeeping around alarm

Survey of zone valves should include, but not be limited to, the following:

- (1) Locations (relationship to terminals controlled)
- (2) Leaks
- (3) Labeling
- (4) Housekeeping around alarm

Survey of medical gas outlet/inlets should include, but not be limited to, the following:

- (1) Flow and function
- (2) Latching/delatching
- (3) Leaks
- (4) General condition (noninterchangeable indexing)

The facility should retain a written or an electronic copy of all findings and any corrections performed.

**A.5.3** A Category 3 vacuum system is not intended for Category 1 medical-surgical vacuum applications. A Category 3 wet piping system is designed to accommodate liquid, air-gas, and solids through the service inlet. A Category 3 dry piping system is designed to accommodate air-gas only through the service inlet, with liquids and solids being trapped before entering the system.

**A.5.3.1** Section 5.1 covers requirements for Category 1 piped gas and vacuum systems; Section 5.2 covers Category 2 piped gas and vacuum systems; and Section 5.3 covers Category 3 piped gas and vacuum systems. Laboratory systems are no longer covered by Chapter 5 (2002 edition).

**A.5.3.1.5** Category 3 medical gas systems are intended to be used where minimal or moderate sedation is administered. Deep sedation and general anesthesia are not allowed in Category 3; therefore, WAGD is not required. (See *Scavenging*, 5.3.8.)

**A.5.3.6.8** The intent is to provide an oxygen-free atmosphere within the tubing and to prevent the formation of copper oxide scale during brazing. This is accomplished by filling the piping with a low-volume flow of low pressure inert gas.

**A.5.3.6.11.2** One of the major concerns is the cross connection of piping systems of different gases. The reason for different sizes is to prevent cross connections, not for capacity concerns.

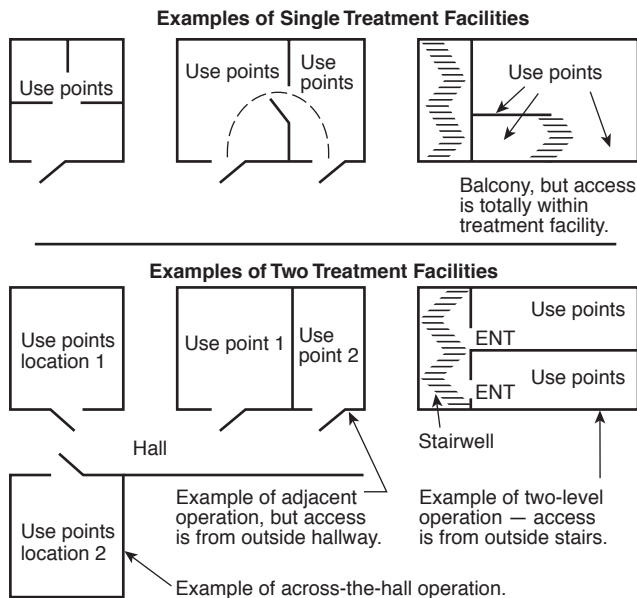
**A.5.3.6.17** Service outlets can be recessed or otherwise protected from damage.

**A.5.3.6.17.1** This configuration will ensure that the required pressure and flow meet the secondary equipment manufacturer's requirements.

**A.5.3.6.19.1** See Figure A.5.3.6.19.1 for an illustration of single treatment locations.

**A.5.3.6.23.2.3(E)** Ammonia is known to cause stress cracking in copper and its alloys.

**A.5.3.6.23.3.9** The detector used for total hydrocarbons is calibrated with a gas that has a known quantity of methane. When a sample is run with this calibrated detector, the result



**FIGURE A.5.3.6.19.1** Examples of Single Treatment Locations.

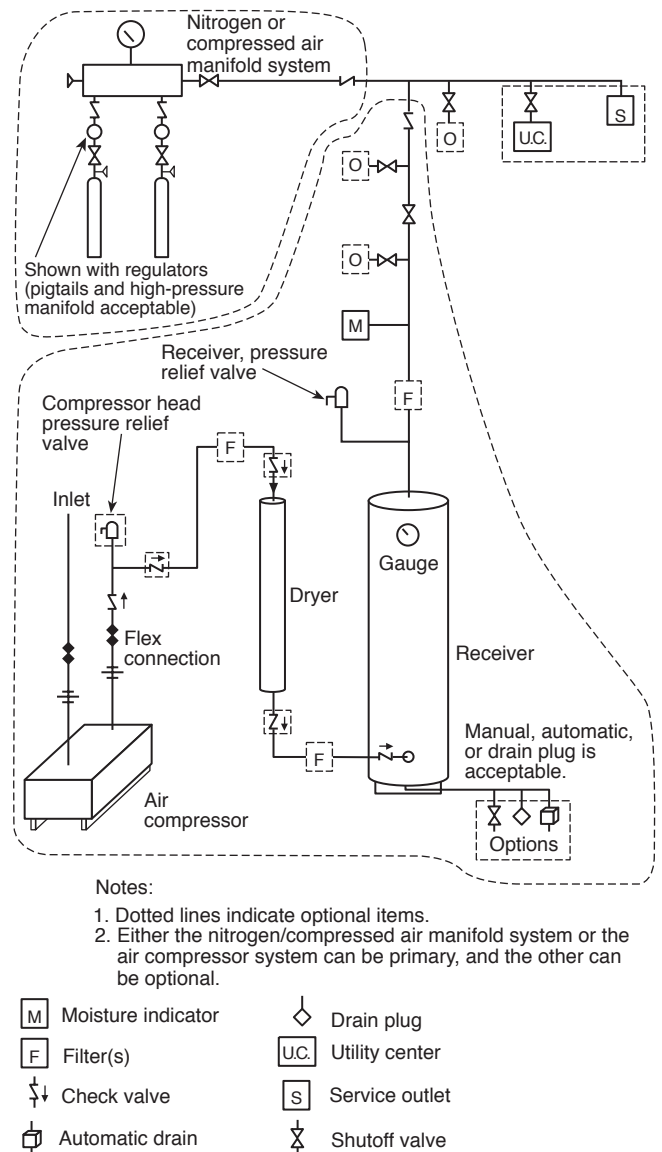
will be total hydrocarbons as methane. Since methane is the one hydrocarbon that does not interact with the body and is present in all air and most oxygen, the actual amount of methane in the sample is subtracted from the total hydrocarbon result to give total non-methane hydrocarbons.

**A.5.3.6.23.3.11** The committee recognizes that current clinical practice is to use analyzers that might not be able to analyze oxygen to current USP requirements of 99 percent and that these analyzers frequently have an error of up to 3 percent.

**A.5.3.7** Category 3 drive gas systems are supplied by one or more of the following:

- (1) Compressed air from compressors
- (2) Compressed air from cylinders
- (3) Nitrogen from cylinders

These systems are used primarily to drive gas-powered power devices. See Figure A.5.3.7 for an illustration of this type



**FIGURE A.5.3.7** Category 3 Drive Gas Supply System.



of system. Similar applications are found in podiatry and plastic surgery. Examples of these are air used to drive turbine-powered drills and air used to dry teeth and gums. Some dental hand pieces have an internal self-contained air return system, while other hand pieces discharge air into the atmosphere. Some discharge a mixture of air and water. Nitrogen is often piped as an alternate or reserve supply to the compressor system.

Dental compressed air is not used for life-support purposes, such as respirators, intermittent positive pressure breathing (IPPB) machines, analgesia, anesthesia, and so forth. Air discharged into the oral cavity is incidental and not a primary source of air to sustain life.

A dental compressed air system should not be used to provide power for an air-powered evacuation system without specific attention paid to the discharge of the evacuated gases and liquids. An open discharge of evacuated gases into the general environment of an operatory could compromise the quality of breathing air in the treatment facility. Air discharge should be vented to the outside of the building through a dedicated vent.

An air-powered evacuation system might require significant quantities of air to operate.

Manufacturer's recommendations should be followed regarding proper sizing of the air compressor. Inadequate sizing can result in overheating, premature compressor failures, and inadequate operating pressures and flows.

**A.5.3.7.1.3** Drive gas quality can be compromised, and the expected life of system components can be shortened if an undersized system is installed. Manufacturer's recommendations should be followed regarding proper sizing of the air compressor(s).

**A.5.3.7.6.3** A color dew point monitor downstream of the receiver indicating the quality of air coming into the receiver is desirable.

A color dew point monitor in the main treatment facility is appropriate to help the staff promptly identify when the system is being degraded with air of a dew point higher than is acceptable.

The design of the color monitor should be such that the normal tolerance of variations will limit the maximum moisture at 3.9°C at 690 kPag (39°F at 100 psig) at activation.

**A.5.3.7.6.5** The environmental air source for the compressor inlet should take into consideration possible contamination by particulates, concentrations of biological waste contaminants, ozone from nearby brush-type electric motors, and exhaust fumes from engines.

Air taken from an outside atmosphere could cause harmful condensation problems in the compressor. Long runs of inlet tube should also be avoided, as they will degrade compressor performance. The compressor manufacturer's recommendations should be followed regarding appropriate pipe size to prevent possible degradation of system performance.

A dental air compressor and dental vacuum system can be in the same equipment room as long as the inlet for the dental air compressor does not draw air from a room or space containing an open discharge for the dental vacuum system.

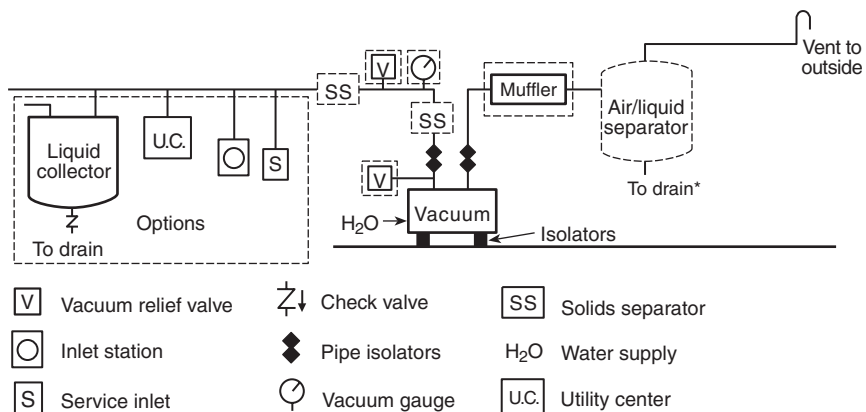
Atmospheric air from an operatory can have traces of mercury vapor, nitrous oxide, and other contaminants. A compressor inlet location that would draw its supply directly from an operatory should be avoided.

**A.5.3.7.8** If nitrogen is used as a backup supply to a compressed gas system, the nitrogen operating pressure should be regulated so as not to exceed the operating pressure of the Category 3 compressed air system.

**A.5.3.8.3.9** A Category 3 vacuum system is not intended for Category 1 vacuum applications. A wet piping system is designed to accommodate liquid, air-gas, and solids through the service inlet. A dry piping system is designed to accommodate air-gas only through the service inlet, with liquids and solids being trapped before entering the system. [See Figure A.5.3.8.3.9(a) through Figure A.5.3.8.3.9(d).]

**A.5.3.8.3.10.4** Improper design allows gas pressure to build up in the ventilation system, which might blow the trap on liquid seals. See Figure A.5.3.8.3.10.4(a) and Figure A.5.3.8.3.10.4(b).

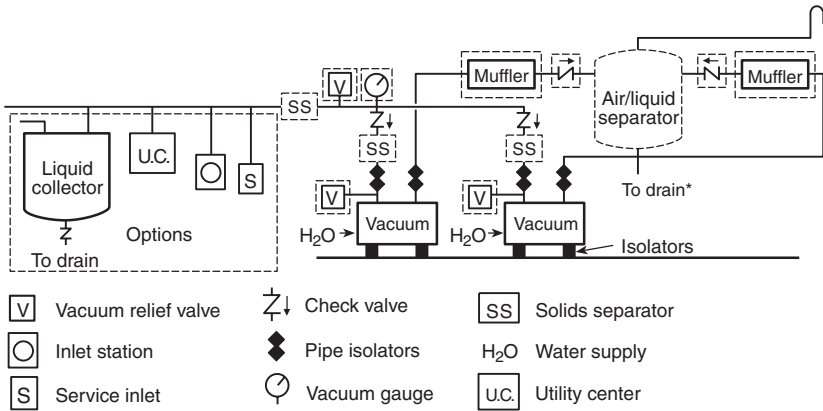
**A.5.3.8.3.11(8)** Care should be taken to ensure the dual exhaust systems do not develop excessive back pressure when using a common exhaust line.



Note: Dotted lines indicate optional items.

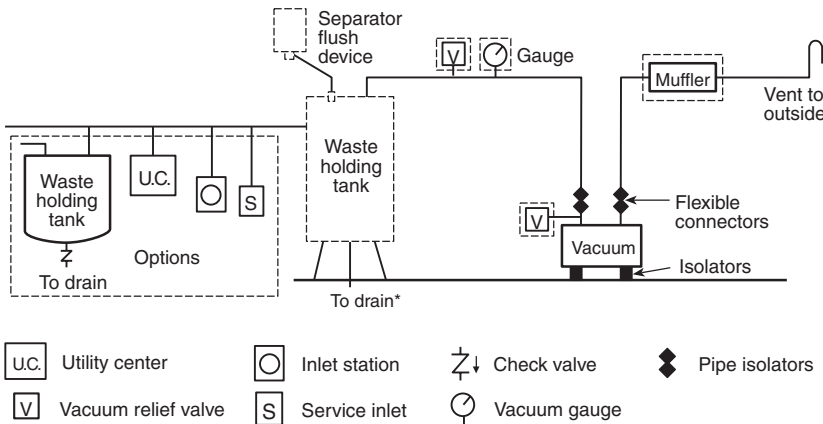
\*Does not have to be below floor.

**FIGURE A.5.3.8.3.9(a) Typical Category 3 Wet or Dry Piping System with Single Vacuum Pump Source.**



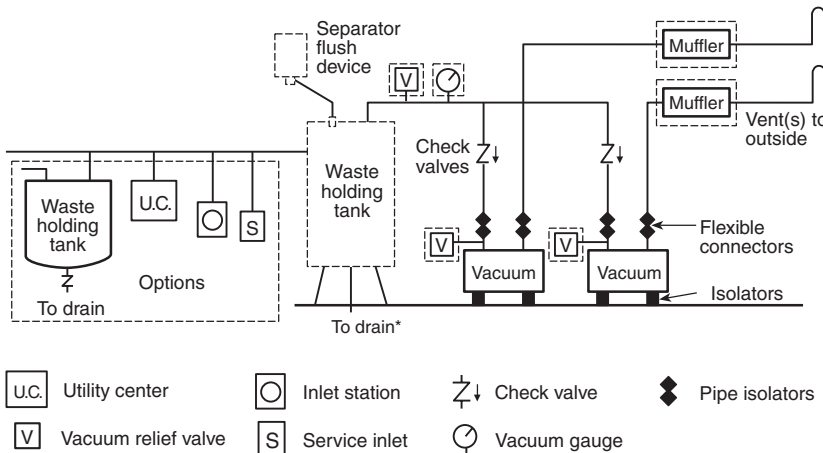
Note: Dotted lines indicate optional items.  
\*Does not have to be below floor.

**FIGURE A.5.3.8.3.9(b) Typical Category 3 Wet or Dry Piping System with Duplex Vacuum Source with Air/Liquid Separator.**



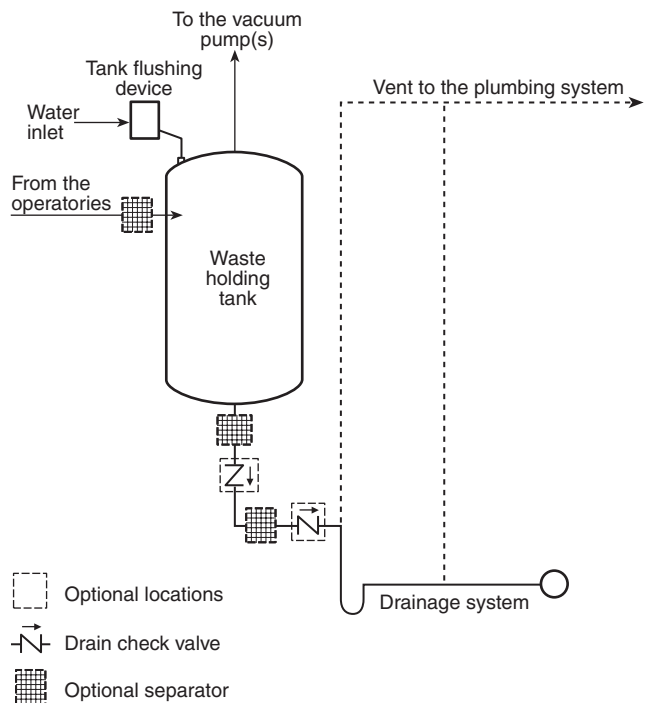
Note: Dotted lines indicate optional items.  
\*Does not have to be below floor.

**FIGURE A.5.3.8.3.9(c) Typical Category 3 Wet or Dry Piping System with Single Vacuum Source.**

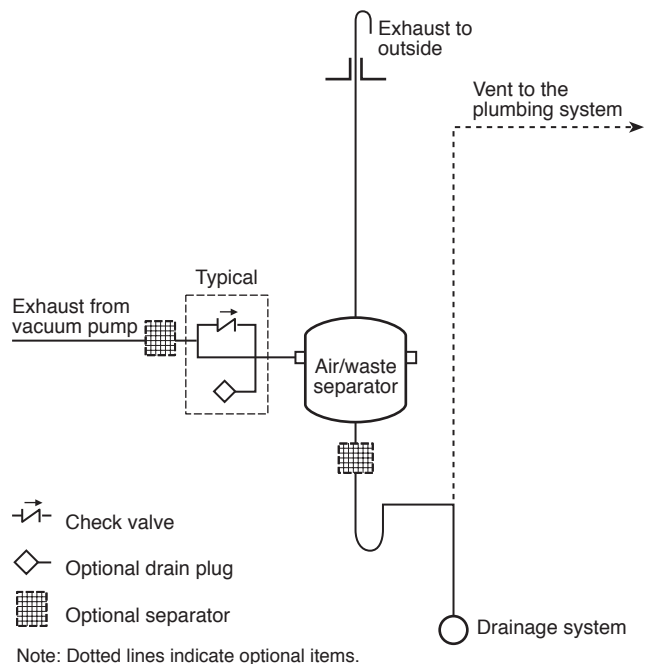


Note: Dotted lines indicate optional items.  
\*Does not have to be below floor.

**FIGURE A.5.3.8.3.9(d) Typical Category 3 Wet or Dry Piping System with Duplex Vacuum Source with Waste Holding Tank.**

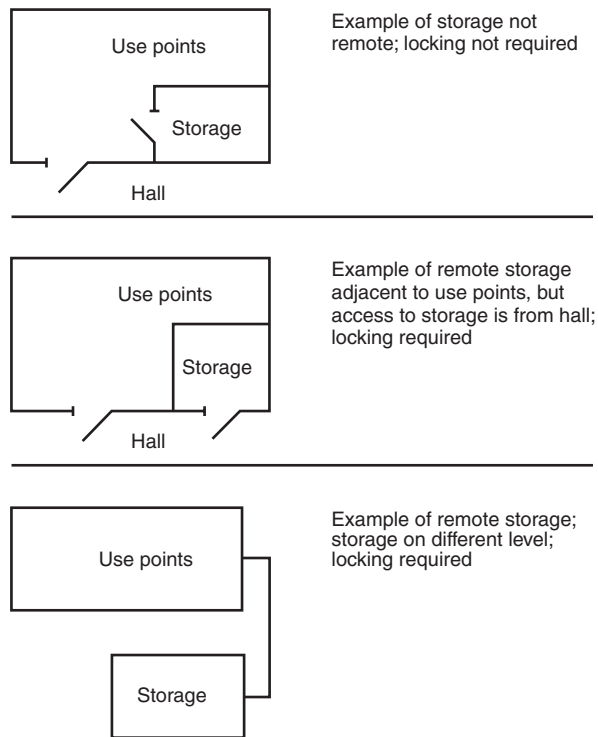


**FIGURE A.5.3.8.3.10.4(a) Drainage from Gravity Drained Liquid Collector Tank.**



**FIGURE A.5.3.8.3.10.4(b) Drainage from Positive Discharge Vacuum Pump Through Air/Liquid Separator.**

**A.5.3.12** When the storage/supply enclosure is remote from the single treatment facility, it should be locked for security reasons to prevent tampering. Access should be via only authorized staff or fire department. When the enclosure is within the single treatment facility, it is left to the discretion of the single treatment facility management as to whether greater benefit is achieved by immediate access or by security. An enclosure with direct access from a public hallway should be locked. If the door to the enclosure opens onto an exit access corridor, see Figure A.5.3.12.



**FIGURE A.5.3.12 Examples of Storage/Supply Enclosures.**

**A.6.1** Although complete compliance with this chapter is desirable, variations in existing health care facilities should be considered acceptable in instances where wiring arrangements are in accordance with prior editions of this document or afford an equivalent degree of performance and reliability. Such variations could occur, particularly with certain wiring in separate or common raceways, with certain functions connected to one or another system or branch, or with certain provisions for automatically or manually delayed restoration of power from the alternate (emergency) source of power.

**A.6.2.1** Electrical systems can be subject to the occurrence of electrical fires. Grounding systems, overcurrent protective devices, and other subjects discussed in this code could be intended for fire prevention as well as other purposes. This aspect of electrical systems is the primary focus of other NFPA standards and will not be emphasized herein.

**A.6.3.2.2** For additional wiring requirements for anesthetizing locations, see 13.3.1.

**A.6.3.2.2.1** At the time of installation of regular voltage wiring, steps should be taken to ensure that the insulation on each conductor intended to be energized, and on the equipment grounding conductor in systems containing isolated ground receptacles, has not been damaged in the process of installation. When disconnected and unenergized, the resistance should be at least 20 megohms when measured with an ohmmeter having an open-circuit test voltage of at least 500 V dc.

Consideration should be given to providing reasonable accessibility to branch-circuit switching and overcurrent protection devices by the hospital staff in the patient care room. Consideration should also be given to providing labels at each receptacle and on installed equipment indicating the location and identity of the distribution panel serving that power outlet or equipment, especially where the location or identity might not be readily apparent.

**A.6.3.2.2.1.1** The requirement that branch circuits be fed from not more than one distribution panel was introduced for several reasons. A general principle is to minimize possible potential differences between the grounding pins of receptacles in one area by bringing the grounding conductors to a common point. A specific reason is to simplify maintenance by making it easier to find the source for the receptacles in a room. This is particularly a problem in hospitals where emergency conditions might require rapid restoration of power.

**A.6.3.2.2.2.2** This requirement is usually met by appropriate mounting hardware and not by wire jumpers.

**A.6.3.2.2.3** The requirement for grounding interconnection between the normal and essential power systems follows the principle of minimizing possible potential differences between the grounding pins of receptacles in one area by bringing the grounding conductors to a common point.

**A.6.3.2.2.4.1** Within the constraints of the equipment provided, consideration should be given to coordinating circuit breakers, fuses, and other overcurrent protective devices so that power interruption in that part of the circuit that precedes the interrupting device closest to a fault is not likely to occur.

**A.6.3.2.2.4.2** Listed Class A ground-fault circuit interrupters trip when a fault current to ground is 6 mA or more.

**A.6.3.2.2.6.1** It is best, if possible, to employ only one type of receptacle (standard three-prong type) for as many receptacles being served by the same line voltage to avoid the inability to connect life-support equipment in emergencies. The straight-blade, three-prong receptacle is now permitted in all locations in a hospital. Previously, special receptacles were specified in operating room locations and have caused compatibility problems.

**A.6.3.2.2.7.1** Care should be taken in specifying a system containing isolated ground receptacles, because the grounding impedance is controlled only by the grounding wires and does not benefit from any conduit or building structure in parallel with it.

**A.6.3.2.2.7.3** Special grounding methods could be required in patient vicinities immediately adjacent to rooms containing high-power or high-frequency equipment that causes electrical interference with monitors or other electromedical devices. In extreme cases, electromagnetic induction can cause the voltage limits of 6.3.3.1 to be exceeded.

Electromagnetic interference problems can be due to a variety of causes, some simple, others complex. Such problems are best solved one at a time. In some locations, grounding of

stretchers, examining tables, or bed frames will be helpful. Where necessary, a patient equipment grounding point should be installed. This can usually be accomplished even after completion of construction by installing a receptacle faceplate fitted with grounding posts. Special grounding wires should not be used unless they are found to be essential for a particular location, because they can interfere with patient care procedures or present trip hazards.

**A.6.3.2.2.8.1** Moisture can reduce the contact resistance of the body, and electrical insulation is more subject to failure.

**A.6.3.2.2.8.2(2)** Class A GFCIs trip at currents between 4 mA and 6 mA.

**A.6.3.2.2.8.4** In conducting a risk assessment, the health care governing body should consult with all relevant parties, including, but not limited to, clinicians, biomedical engineering staff, and facility safety engineering staff.

**A.6.3.2.2.8.7** The health care governing body and designer of record should evaluate the type of protection to be provided against electrical shock to patients and caregivers in wet procedure locations. The application considerations should include but not be limited to the reliability of power to critical equipment and systems.

**A.6.3.2.6** Patient protection is provided primarily by an adequate grounding system. The ungrounded secondary of the isolation transformer reduces the cross-sectional area of grounding conductors necessary to protect the patient against voltage resulting from fault current by reducing the maximum current in case of a single probable fault in the grounding system. The line isolation monitor is used to provide warning when a single fault occurs. Excessive current in the grounding conductors will not result in a hazard to the patient unless a second fault occurs. If the current in the grounding system does not exceed 10 mA, even under fault conditions, the voltage across 3 m (9.84 ft) of No. 12 AWG wire will not exceed 0.2 mV, and the voltage across 3 m (9.84 ft) of No. 18 AWG grounding conductor in a flexible cord will not exceed 0.8 mV. Allowing 0.1 mV across each connector, the voltage between two pieces of patient-connected equipment will not exceed 2 mV.

The reference grounding point is intended to ensure that all electrically conductive surfaces of the building structure, which could receive heavy fault currents from ordinary (grounded) circuits, are grounded in a manner to bypass these heavy currents from the operating room.

**A.6.3.2.6.2.1** It is desirable to limit the size of the isolation transformer to 10 kVA or less and to use conductor insulation with low leakage to meet the impedance requirements. Keeping branch circuits short and using insulation with a dielectric constant less than 3.5 and insulation resistance constant greater than 6100 megohmmeters at 16°C (20,000 megohm-ft at 60°F) reduces leakage from line to ground.

To correct milliammeter reading to line impedance, use the following equation:

$$\text{Line impedance (in ohms)} = \frac{V \times 100}{I}$$

where:

*V* = isolated power system voltage

*I* = milliammeter reading made during impedance test

**A.6.3.2.6.3.1** Protection for the patient is provided primarily by a grounding system. The ungrounded secondary of the isolation transformer reduces the maximum current in the grounding system in case of a single fault between either isolated power conductor and ground. The line isolation monitor provides warning when a single fault occurs, or when excessively low impedance to ground develops, which might expose the patient to an unsafe condition if an additional fault occurs. Excessive current in the grounding conductors will not result from a first fault. A hazard exists if a second fault occurs before the first fault is cleared.

**A.6.3.2.6.3.3** It is desirable to reduce this monitor hazard current, provided that this reduction results in an increased “not alarm” threshold value for the fault hazard current.

**A.6.3.2.6.3.4** It is desirable to locate the ammeter such that it is conspicuously visible to persons in the anesthetizing location.

The line isolation monitor can be a composite unit, with a sensing section cabled to a separate display panel section on which the alarm and test functions are located, if the two sections are within the same electric enclosure.

**A.6.3.3.1.1** In a conventional grounded power distribution system, one of the line conductors is deliberately grounded, usually at some distribution panel or the service entrance. This grounded conductor is identified as the neutral conductor. The other line conductor (s) is the high side of the line. The loads to be served by this distribution system are fed by the high and neutral conductors.

In addition to the high and neutral conductors, a grounding conductor is provided. One end is connected to the neutral at the point where the neutral is grounded, and the other end leads out to the connected loads. For purposes here, the load connection point will be considered to be a convenience receptacle, with the grounding conductor terminating at the grounding terminal of that receptacle.

This grounding conductor can be a separate wire running from the receptacle back to the remote grounding connection (where it joins the neutral conductor). If that separate conductor does not make any intermediate ground contacts between the receptacle and the remote ground, then the impedance of the connection between the receptacle and the remote ground is primarily the resistance of the grounding conductor itself and is, therefore, predictable.

If, however, the receptacle is also interconnected with the remote ground point by metallic conduit or other metallic building structures, the impedance of the circuit between the receptacle and remote ground is not easily predictable; nor is it easy to measure accurately, although one can be sure that the impedance will be less than that of the grounding wire itself because of the additional parallel paths.

Fortunately, as will become apparent in the paragraphs that follow, the absolute value of the apparent impedance between the grounding contact of an outlet and the remote ground point need not be known or measured with great accuracy.

Ideally, and under no-fault conditions, the grounding system described earlier is supposed to be carrying no current at all. If this were true, then no voltage differences would be found between exposed conductive surfaces of any electrical appliances that were grounded to the grounding contacts of the receptacles that powered them. Similarly, there would be no voltage differences between these appliances and any other exposed metal surface that was also interconnected with the grounding system, provided that no currents were flowing in that interconnection.

Ideal conditions, however, do not prevail, and even when there are no “faults” within an appliance, residual “leakage” current does flow in the grounding conductor of each of the appliances, producing a voltage difference between the chassis of that appliance and the grounding contact of the receptacle that feeds it. Furthermore, this current can produce voltage differences among other appliances plugged into various receptacles on the system.

Fortunately, these leakage currents are small, and for reasonably low grounding-circuit impedances, the resulting voltage differences are entirely negligible.

If, however, a breakdown of insulation between the high side of the line and the chassis of an appliance occurs, the leakage condition becomes a fault condition, the magnitude of which is limited by the nature of the breakdown, or, in the case of a dead short circuit in the appliance, the magnitude of the fault current is limited only by the residual resistance of the appliance power cord conductors and that of the power distribution system.

In the event of such a short circuit, the impedance of the grounding circuit, as measured between the grounding contact of the receptacle that feeds the defective appliance and the remote ground point where the neutral and grounding conductors are joined, should be so small that a large enough fault current will flow to ensure a rapid breaking of the circuit by the overcurrent protective device that serves that receptacle.

For a 20-A branch circuit, a fault current of 40 A or more would be required to ensure a rapid opening of the branch-circuit overcurrent protective device. This corresponds to a circuit impedance of 3 ohms or less, of which the grounding system should contribute 1 ohm or less.

During the time this large fault current flows in the grounding system, the chassis of the defective appliance is raised many volts above other grounded surfaces in the same vicinity. The hazard represented by this condition is minimized by the fact that it exists for only a short time, and, unless a patient simultaneously contacts both the defective appliance and some other grounded surface during this short time interval, there is no hazard. Furthermore, the magnitude of an applied voltage required to produce a serious shock hazard increases as its duration decreases, so the rapidity with which the circuit is interrupted helps reduce shock hazard even if such a patient contact occurs.

If, however, the defect in the appliance is not such as to cause an immediate circuit interruption, then the effect of this intermediate level of fault current on the voltages appearing on various exposed conductive surfaces in the patient care vicinity should be considered.

Because all of this fault current flows in the grounding conductor of the defective appliance’s power cord, the first effect is to raise the potential of this appliance above that of the receptacle that feeds it by an amount proportional to the power cord grounding conductor resistance. This resistance is required to be less than 0.15 ohm, so fault currents of 20 A or less, which will not trip the branch-circuit overcurrent protective device, will raise the potential of the defective appliance above the grounding contact of its supply receptacle by only 3 V or less. This value is not hazardous for casual contacts.

The fault current that enters the grounding system at the grounding contact of any receptacle in the patient care vicinity could affect the potential at the grounding contacts of all the other receptacles, and, more importantly, it could produce significant voltage differences between them and other grounded surfaces, such as exposed piping and building structures.

If one grounded point is picked as a reference (a plumbing fixture in or near the patient care vicinity, for example), and the voltage difference is then measured between that reference and the grounding contact of a receptacle, produced by driving some known current into that contact, a direct measure of the effectiveness of the grounding system within the patient care vicinity is obtained. The “figure of merit” can be stated as so many volts per ampere of fault current. The ratio volts per ampere is, of course, impedance; but because the exact path taken by the fault current is not known, and because the way in which the reference point is interconnected with the grounding system is not known, it cannot be stated that this value is the impedance between the receptacle and some specific point, such as the joining of the neutral and grounding conductors. However, it can be stated that this measured value of “effective impedance” is indicative of the effectiveness with which the grounding system minimizes voltage differences between supposedly grounded objects in the patient care vicinity that are produced by ground faults in appliances used in that vicinity. This impedance, which characterizes the ability of the grounding system to maintain nearly equipotential conditions within the patient care vicinity, is of prime importance in assessing shock hazard; but this impedance is not necessarily the same as the impedance between receptacle and remote ground point, which controls the magnitude of the short-circuit current involved in tripping the branch-circuit overcurrent protective device.

Fault currents on the grounding system can also come from neutral-to-ground faults, which allow some current to flow in the neutral and some in the ground. This type of fault is often the cause of interference on EEG and ECG equipment. It is often not recognized easily because, except for 60 Hz interference, the equipment works perfectly properly. It is most easily found by causing a substantial change in the line-to-line load and noting changes in the ground-to-reference voltage.

**A.6.3.3.1.1.4** The grounding system (reference ground and conduit) is to be tested as an integral system. Lifting of grounds from receptacles and fixed equipment is not required or recommended for the performance of this test.

**A.6.3.3.1.3** Effective grounding to safely handle both fault and leakage currents requires following the requirements of both Chapter 6 of NFPA 99 and Article 250 of *NFPA 70, National Electrical Code*, having good workmanship; and using some techniques that are not found in these documents.

The performance of the grounding system is made effective through the existence of the green grounding wire, the metal raceway, and all of the other building metal. Measurements have shown that it is the metal raceway and building steel that provide most of the effective grounding path of less than 10 milliohms at the receptacle, including plug-to-receptacle impedance. The green grounding wire becomes a backup, not a primary grounding path performer.

Good practice calls for each receptacle to have a good jumper grounding connection to the metal raceway at the receptacle location in addition to having the green grounding wire connecting these points to the grounding bus in the distribution panel. Good workmanship includes seeing that these grounding connections are tight at each receptacle and that all metal raceway joints are secure and tight.

The voltage difference measurements listed in 6.3.3.1.3 in connection with power distribution grounding systems should ideally be made with an oscilloscope or spectrum analyzer in order to observe and measure components of leakage current and voltage differences at all frequencies.

For routine testing, such instruments could be inconvenient. An alternative is to use a metering system that weighs the contribution to the meter reading of the various components of the signal being measured in accordance with their probable physiological effect.

A meter specifically designed for this purpose would have an impedance of approximately 1000 ohms, and a frequency characteristic that was flat to 1 kHz, dropped at the rate of 20 decibels per decade to 100 kHz, and then remaining flat to 1 MHz or higher. This frequency response characteristic could be achieved by proper design of the internal circuits of the amplifier that probably precedes the indicating instrument or by appropriate choice of a feedback network around the amplifier. These details are, of course, left to the instrument designer.

If a meter specifically designed for these measurements is not available, a general-purpose laboratory millivoltmeter can be adapted for the purpose by adding a frequency response-shaping network ahead of the meter. One such suggested network is shown in Figure A.6.3.3.1.3(a).

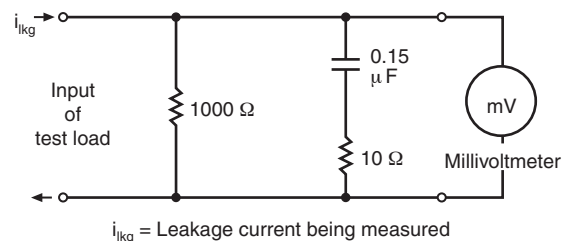
The circuit shown in Figure A.6.3.3.1.3(a) is especially applicable to measurements of leakage current, where the current being measured is derived from a circuit whose source impedance is high compared to 1000 ohms. Under these conditions, the voltage developed across the millivoltmeter will be proportional to the impedance of the network. The network impedance will be 1000 ohms at low frequencies and 10 ohms at high frequencies, and the transition between these two values will occur in the frequency range between 1 kHz and 100 kHz.

The basic low-frequency sensitivity will be 1 mV of meter reading for each 1 mA of leakage current.

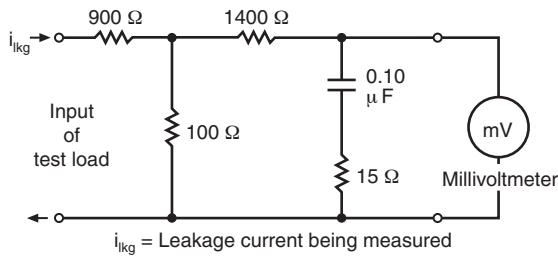
The millivoltmeter’s own input impedance needs to be very large compared to 1000 ohms (100 kilohms), and the meter should have a flat frequency response to well beyond 100 kHz. (If the meter impedance is lower than 100 kilohms, then the 1000 ohm resistor can be raised to a higher value, such that the impedance of that resistor in parallel with the meter will still be 1000 ohms.)

The circuit in Figure A.6.3.3.1.3(a) can be used for the voltage difference measurements required in Section 6.5, but, because the source impedance will be very low compared to 1000 ohms, the frequency response of the measurement system will remain flat. If any high-frequency components produced, for example, by pickup from nearby radio frequency transmitters appear on the circuit being measured, then they will not be attenuated, and the meter reading will be higher than it should be.

For meter readings below any prescribed limits, this possible error is of no consequence. For borderline cases, it could be significant. To avoid this uncertainty when making voltage-difference measurements, a slightly more elaborate version of a frequency response-shaping network is given in Figure A.6.3.3.1.3(b).



**FIGURE A.6.3.3.1.3(a) Circuit Used to Measure Leakage Current with High Source Impedance.**



**FIGURE A.6.3.3.1.3(b) Circuit Used to Measure Leakage Current with Low Source Impedance.**

Here the source being measured is separated from the frequency response-shaping network by the combination of the 900 ohm and 100 ohm resistors. The frequency response characteristic is now independent of the circuit being tested.

This independence is achieved, however, at a loss in signal delivered to the millivoltmeter. The basic low-frequency sensitivity of this metering circuit is 1 mV of meter reading for 10 A of leakage current or, on a voltage basis, 1 mV of meter reading for 10 mV at the input terminals of the network.

The millivoltmeter should have an input impedance of 150 kilohms and a frequency response that is flat to well beyond 100 kHz.

For either of the suggested networks, the resistors and capacitors should be mounted in a metal container close to the millivoltmeter to avoid stray pickup by the leads going to the meter.

**A.6.3.3.1.4** It is not the intent that each receptacle be tested. It is intended that compliance be demonstrated through random testing. The 10 percent random testing should include a mixture of both normal and emergency receptacles.

**A.6.3.4** Administration is in conjunction with 6.3.4.1.

**A.6.3.4.2.1** Although several approaches to documentation exist in hospitals, the minimum acceptable documentation should identify what was tested, when it was tested, and whether it performed successfully. Adopting a system of exception reporting can be the most efficient form of record keeping for routine rechecks of equipment or systems, thereby minimizing technicians' time in recording the value of each measurement taken. For example, once a test protocol is established, which simply means testing the equipment or system consistent with Chapter 6, the only item (value) that needs to be recorded is the failure or the deviation from the requirements of the chapter that was detected when a corrective action (repair) was undertaken. This approach can serve to eliminate, for example, the need to keep individual room sheets to record measured results on each receptacle or to record measurement values of all types of leakage current tests.

**A.6.4.1.1.1** *Connection to Dual Source of Normal Power.* For the greatest assurance of continuity of electrical service, the normal source should consist of two separate full-capacity services, each independent of the other. Such services should be selected and installed with full recognition of local hazards of interruption, such as icing and flooding.

Where more than one full-capacity service is installed, they should be connected in such a manner that one will pick up the load automatically upon loss of the other, and should be so arranged that the load of the emergency and equipment systems will be transferred to the alternate source (generator set)

only when both utility services are de-energized, unless this arrangement is impractical and waived by the authority having jurisdiction. Such services should be interlocked in such a manner as to prevent paralleling of utility services on either primary or secondary voltage levels.

Note that, in any installation where it is possible to parallel utility supply circuits (e.g., to prevent interruption of service when switching from one utility source to another) it is imperative to consult the power companies affected as to problems of synchronization.

Facilities whose normal source of power is supplied by two or more separate central station-fed services (dual sources of normal power) experience greater reliability than those with only a single feed.

*Installation of Generator Sets.* For additional material on diesel engines, see National Research Council Publication 1132, *Diesel Engines for Use with Generators to Supply Emergency and Short Term Electric Power* (see Annex D).

**A.6.4.1.1.2(5)** Careful consideration should be given to the location of the spaces housing the components of the essential electrical system to minimize interruptions caused by natural forces common to the area (e.g., storms, floods, or earthquakes; or hazards created by adjoining structures or activities). Consideration should also be given to the possible interruption of normal electrical services resulting from similar causes as well as possible disruption of normal electrical service due to internal wiring and equipment failures.

Consideration should be given to the physical separation of the main feeders of the essential electrical system from the normal wiring of the facility to prevent possible simultaneous destruction as a result of a local catastrophe.

In selecting electrical distribution arrangements and components for the essential electrical system, high priority should be given to achieving maximum continuity of the electrical supply to the load. Higher consideration should be given to achieving maximum reliability of the alternate power source and its feeders rather than protection of such equipment, provided that the protection is not required to prevent a greater threat to human life such as fire, explosion, electrocution, and so forth, than would be caused by the lack of an essential electrical supply.

**A.6.4.1.1.7.3** The intent of 6.4.1.1.7.3 is as follows:

- (1) Contiguous or same-site nonhospital buildings can be served by the generating equipment. However, such loads should not compromise the integrity of the system serving the hospital. Thus, any such contiguous or same-site nonhospital buildings can be served by the generating equipment only if the transfer means operates in accordance with 6.4.1.1.7.3.
- (2) Within a hospital building, 6.4.2.2.4.2(9) permits "additional" loads on the critical branch and 6.4.2.2.5.4(9) permits "other equipment" on the equipment system in order to provide limited flexibility to a facility to add one or two loads not otherwise listed in 6.4.2.2.4.2(1) through (8), 6.4.2.2.5.3, or 6.4.2.2.5.4(1) through (9) to a critical branch panel or an equipment system panel. This is permitted to prevent the need for an additional panel to serve a small number of selected circuits in a particular area. These sections are not intended to permit large blocks of loads not listed in these sections to be on the critical branch or equipment system. The intent of the division of the essential

system loads into systems and branches is to ensure maximum reliability of service to loads considered essential. Every additional load placed onto a system somewhat increases the probability of a failure on the system that threatens the integrity of service to the balance of loads served by the system. Therefore, while “additional” loads and “other equipment” are permitted to be placed onto the critical branch and equipment system in very limited situations, where a facility wants to put large blocks of loads not listed in 6.4.2.2.4.2(1) through (8), 6.4.2.2.5.3, or 6.4.2.2.5.4(1) through (9) onto the generating equipment, the facility is permitted to do so, but only by designating these large blocks of loads as “optional loads” and by complying with 6.4.1.1.7.3.

**A.6.4.1.1.9** It is the intent of 6.4.1.1.9 to mandate generator sizing based upon actual demand likely to be produced by the connected load of the essential electrical system(s) at any one time. It is not the intent that generator sizing be based upon connected load or feeder calculation procedures described in *NFPA 70, National Electrical Code*. Demand calculations should be based upon prudent demand factors and historical data.

**A.6.4.1.1.12** During operation, EPS and related equipment reject considerable heat that needs to be removed by proper ventilation or air-cooling. In some cases, outdoor installations rely on natural air circulation, but enclosed installations need properly sized, properly positioned ventilation facilities, to prevent recirculation of cooling air. The optimum position of air-supply louvers and radiator air discharge is on opposite walls, both to the outdoors. [110: A.7.7.1]

**A.6.4.1.1.17.1** As a supplement to hard-wired alarm annunciations, it is permissible to have Level 1 and Level 2 EPS and ATS functions monitored off-site. Monitoring stations can include pagers, cell phones, and Internet-connected devices.

**A.6.4.2** It should be emphasized that the type of system selected and its area and type of coverage should be appropriate to the medical procedures being performed in the facility. For example, a battery-operated emergency light that switches “on” when normal power is interrupted and an alternate source of power for suction equipment, along with the immediate availability of some portable hand-held lighting, would be advisable where oral and maxillofacial surgery (e.g., extraction of impacted teeth) is performed. On the other hand, in dental offices where simple extraction, restorative, prosthetic, or hygienic procedures are performed, only remote corridor lighting for purposes of egress would be sufficient. Emergency power for equipment would not be necessary. As with oral surgery locations, a surgical clinic requiring use of life-support or emergency devices, such as suction machines, ventilators, cauterizers, or defibrillators, would require both emergency light and power.

**A.6.4.2.1.2** It is important that the various overcurrent devices be coordinated, as far as practicable, to isolate faulted circuits and to protect against cascading operation on short-circuit faults. In many systems, however, full coordination could compromise safety and system reliability. Primary consideration also should be given to prevent overloading of equipment by limiting the possibilities of large current in-

rushes due to instantaneous reestablishment of connections to heavy loads.

**A.6.4.2.1.5.1(A)** Where special loads require more rapid detection of power loss, underfrequency monitoring also might be provided. Upon frequency decay below the lower limit necessary for proper operation of the loads, the transfer switch should automatically initiate transfer to the alternate source. (See A.6.2.15 of *NFPA 110*.) [110: A.6.2.2.1]

**A.6.4.2.1.5.1(A)(2)** See 6.2.5 and 6.2.7 of *NFPA 110*. [110: A.6.2.2.1(2)]

**A.6.4.2.1.5.3** Authorized personnel should be available and familiar with manual operation of the transfer switch and should be capable of determining the adequacy of the alternate source of power prior to manual transfer. [110: A.6.2.4]

**A.6.4.2.1.5.4** For most applications, a nominal delay of 1 second is adequate. The time delay should be short enough so that the generator can start and be on the line within the time specified for the type classification. [110: A.6.2.5]

**A.6.4.2.1.5.7** It is recommended that the timer for delay on retransfer to the primary source be set for 30 minutes. The 30-minute recommendation is to establish a “normalized” engine temperature, when it is beneficial for the engine. *NFPA 70, National Electrical Code*, establishes a minimum time requirement of 15 minutes. [110: A.6.2.8]

**A.6.4.2.1.5.12** For maintenance purposes, consideration should be given to a transfer switch counter. [110: A.6.2.13]

**A.6.4.2.1.5.14** Automatic transfer switches (ATS) can be provided with accessory controls that provide a signal to operate remote motor controls that disconnect motors prior to transfer, and to reconnect them after transfer when the residual voltage has been substantially reduced. Another method is to provide inphase monitors within the ATS in order to prevent retransfer to the primary source until both sources are nearly synchronized. A third method is to use a programmed neutral position transfer switch. See Section 230.95(B) of *NFPA 70, National Electrical Code*. [110: A.6.2.15]

**A.6.4.2.1.5.15** Standards for nonautomatic transfer switches are similar to those for automatic transfer switches, as defined in 3.3.7.1 and 3.3.7.3 of *NFPA 110, Standard for Emergency and Standby Power Systems*, with the omission of automatic controls. [110: A.6.2.16]

**A.6.4.2.1.8.3** Consideration should be given to the effect that load interruption could have on the load during maintenance and service of the transfer switch.

**A.6.4.2.2.1** Type 1 essential electrical systems are comprised of three separate branches capable of supplying a limited amount of lighting and power service that is considered essential for life safety and effective facility operation during the time the normal electrical service is interrupted for any reason. These three separate branches are the life safety, critical, and equipment branches.

**A.6.4.2.2.3.2(3)** Departmental installations such as digital dialing systems used for intradepartmental communications could have impaired use during a failure of electrical service to the area. In the event of such failure, those systems that have lighted selector buttons in the base of the telephone instrument or in the desk units known as “director sets” will be out of service to the extent that the lights



will not function and that the buzzer used to indicate incoming calls will be silenced. The lack of electrical energy will not prevent the use of telephones for outgoing calls, but incoming calls will not be signaled, nor will intercommunicating calls be signaled. This communication failure should be taken into consideration in planning essential electrical systems.

**A.6.4.2.2.4** It is recommended that facility authorities give consideration to providing and properly maintaining automatic battery-powered lighting units or systems to provide minimal task illumination in operating rooms, delivery rooms, and certain special-procedure radiology rooms, where the loss of lighting due to failure of the essential electrical system could cause severe and immediate danger to a patient undergoing surgery or an invasive radiographic procedure.

**A.6.4.2.2.4.2(7)** Departmental installations such as digital dialing systems used for intradepartmental communications could have impaired use during a failure of electrical service to the area. In the event of such failure, those systems that have lighted selector buttons in the base of the telephone instrument or in the desk units known as “director sets” will be out of service to the extent that the lights will not function and that the buzzer used to indicate incoming calls will be silenced. The lack of electrical energy will not prevent the use of telephones for outgoing calls, but incoming calls will not be signaled, nor will intercommunicating calls be signaled. This communication failure should be taken into consideration in planning essential electrical systems.

**A.6.4.2.2.5.3** The equipment in 6.4.2.2.5.3(A) (1) through (3) can be arranged for sequential delayed-automatic connection to the alternate power source to prevent overloading the generator where engineering studies indicate that it is necessary.

**A.6.4.2.2.5.4** For elevator cab lighting control and signal system requirements, see 6.4.2.2.3.1(6).

In instances where interruption of normal power would result in other elevators stopping between floors, throw-over facilities should be provided to allow the temporary operation of any elevator for the release of patients or other persons who are confined between floors.

**A.6.4.2.2.5.4(2)** The outside design temperature is based on the 97½ percent design value, as shown in Chapter 24 of the ASHRAE *Handbook of Fundamentals*.

**A.6.4.2.2.5.4(9)** Consideration should be given to selected equipment in kitchens, laundries, and radiology rooms and to selected central refrigeration.

It is desirable that, where heavy interruption currents can be anticipated, the transfer load be reduced by the use of multiple transfer devices. Elevator feeders, for instance, might be less hazardous to electrical continuity if they are fed through an individual transfer device.

**A.6.4.2.2.6.1** See *NFPA 70, National Electrical Code*, for installation requirements.

**A.6.4.2.2.6.2(C)** If color is used to identify these receptacles, the same color should be used throughout the facility.

**A.6.4.4.1.1.4(A)** When events, such as the issuance of storm warnings, indicate that power outages might be likely, good practice recommends the warming up of generator sets by a regular exercise period. Operation of generator sets for short

intervals should be avoided, particularly with compression ignition engines, since it is harmful to the engines.

Records of changes to the essential electrical system should be maintained so that the actual demand likely to be produced by the connected load will be within the available capacity.

**A.6.4.4.1.2.1** Main and feeder circuit breakers should be periodically tested under simulated overload trip conditions to ensure reliability.

**A.6.5.2.1.1** It is important that the various overcurrent devices be coordinated, as far as practicable, to isolate faulted circuits and to protect against cascading operation on short-circuit faults. In many systems, however, full coordination could compromise safety and system reliability. Primary consideration also should be given to prevent overloading of equipment by limiting the possibilities of large current inrushes due to instantaneous reestablishment of connections to heavy loads.

**A.6.5.2.2.1** Type 2 essential electrical systems are comprised of two separate branches capable of supplying a limited amount of lighting and power service that is considered essential for the protection of life and safety and effective operation of the institution during the time normal electrical service is interrupted for any reason. These two separate branches are the life safety and equipment branches.

The number of transfer switches to be used should be based upon reliability, design, and load considerations. Each branch of the essential electrical system should have one or more transfer switches. One transfer switch should be permitted to serve one or more branches in a facility with a maximum demand on the essential electrical system of 150 kVA (120 kW).

**A.6.5.2.2.2.1(4)** Departmental installations such as digital dialing systems used for intradepartmental communications could have impaired use during a failure of electrical service to the area. In the event of such failure, those systems that have lighted selector buttons in the base of the telephone instrument or in the desk units known as “director sets” will be out of service to the extent that the lights will not function and that the buzzer used to indicate incoming calls will be silenced. The lack of electrical energy will not prevent the use of telephones for outgoing calls, but incoming calls will not be signaled, nor will intercommunicating calls be signaled. This communication failure should be taken into consideration in planning essential electrical systems.

**A.6.5.2.2.3.4** Other selected equipment can be served by the equipment branch.

Note that consideration should be given to selected equipment in kitchens and laundries and to selected central refrigeration.

It is desirable that, where heavy interruption currents can be anticipated, the transfer load be reduced by the use of multiple transfer devices. Elevator feeders, for instance, might be less hazardous to electrical continuity if they are fed through an individual transfer device.

**A.6.5.2.2.3.4(A)(1)** The outside design temperature is based on the 97½ percent design value, as shown in Chapter 24 of the ASHRAE *Handbook of Fundamentals*.

**A.6.5.2.2.3.4(B)** For elevator cab lighting, control, and signal system requirements, see 6.5.2.2.2(6).

**A.6.5.2.2.4.1** See *NFPA 70, National Electrical Code*, for installation requirements.

**A.6.5.2.2.4.2** If color is used to identify these receptacles, the same color should be used throughout the facility.

**A.6.6.2.1.1** It is important that the various overcurrent devices be coordinated, as far as practicable, to isolate faulted circuits and to protect against cascading operation on short-circuit faults. In many systems, however, full coordination could compromise safety and system reliability. Primary consideration also should be given to prevent overloading of equipment by limiting the possibilities of large current inrushes due to instantaneous reestablishment of connections to heavy loads.

**A.6.6.2.2.1** Type 3 essential electrical systems are comprised of a system capable of supplying a limited amount of lighting and power service that is considered essential for life safety and orderly cessation of procedure during the time normal electrical service is interrupted for any reason.

**A.6.6.2.2.3.2** If color is used to identify these receptacles, the same color should be used throughout the facility.

**A.7.1** Additional information on these systems can be found in IEEE 602, *Recommended Practice for Electric Systems in Health Care Facilities*, and FGI *Guidelines for Design and Construction of Health Care Facilities*.

**A.7.3.1.2** Additional information can be found in TIA/EIA 569-B, *Commercial Building Standard for Telecommunications Pathways and Spaces*.

**A.7.3.1.2.1.3(B)** Off-site electronic storage of patient records should also be considered.

**A.7.3.1.2.1.5(B)** Supplying the circuits serving equipment in the telecommunications entrance facility through an uninter-

rupted power system (UPS) provides a desirable level of redundancy.

**A.7.3.1.2.1.6(C)** Consideration should be given to the reliability of power supply to the HVAC equipment because of its important function within the telecommunications entrance facility.

**A.7.3.1.2.2.2** In combined spaces, care should be taken to provide separation of, and adequate service access for, service provider equipment.

**A.8.2.1** There are no interdependencies for each type of system (e.g., medical gas, electrical, potable water, nonpotable water, nonmedical compressed air, heating). A risk assessment of each system should be conducted to evaluate the risk to the patient, staff, and visitors. It is possible when applying this section to identify multiple categories of systems serving a single patient. For example see Table A.8.2.1 and A.4.1.

**A.8.3.3** Another source of maximum hot water temperatures would be FGI *Guidelines for Design and Construction of Health Care Facilities*.

**A.9.2** Table A.9.2 represents a typical analysis for a health care facility. The governing body, or its designate, should complete a system analysis based on its functional program. A table similar to Table A.9.2 can be developed to transfer information from the governing body to designers or authorities having jurisdiction, or both.

**A.9.2.1** There are no interdependencies for each type of system (e.g., medical gas, electrical, potable water, nonpotable water, nonmedical compressed air, plumbing). A risk assessment of each system should be conducted to evaluate the risk to the patient, staff, and visitors. It is possible when applying this section to identify multiple categories of systems serving a single patient. For example see Table A.9.2 and A.4.1.

**Table A.8.2.1 Category Designation by Function — Plumbing**

Function	Potable	Nonpotable	Special Use	Water Conditioning	Water Heating	Process Air	Fuel
Airborne infection isolation room	2	NA	NA	NA	3	NA	NA
Burn patient care rooms	2	NA	NA	NA	3	NA	NA
Business offices/administration	4	4	4	4	4	4	4
Central sterile room	2	NA	NA	NA	3	2	NA
Class A surgical procedures	2	NA	NA	NA	3	NA	NA
Class B surgical procedures	2	NA	NA	NA	3	NA	NA
Class C surgical procedures	2	NA	NA	NA	3	NA	NA
Critical care rooms (Category 1 room)	2	NA	NA	NA	3	NA	NA
Emergency department trauma room	2	NA	NA	NA	3	NA	NA
Hemodialysis	2	NA	2	NA	3	NA	NA
Intensive care	2	NA	NA	NA	3	NA	NA
Medical records	4	4	4	4	4	4	4
Morgue	2	NA	NA	NA	3	NA	NA
PACU	2	NA	NA	NA	3	NA	NA
Patient education	4	4	4	4	4	4	4
Pharmacy	2	NA	NA	NA	3	NA	NA
Protective environment room	2	NA	NA	NA	3	NA	NA
Radiology	2	NA	NA	NA	3	NA	NA
Speech therapy	4	4	4	4	4	4	4
Waiting rooms	4	4	4	4	4	4	4

NA: Not applicable

Note: This is a sample table. The numbers represented in this table might not be consistent with the health care facility scenario.

**Table A.9.2 Category Designation by Function — Heating**

Function	Category			
	Heating	Cooling	Ventilating	Process
Airborne infection isolation room	2	2	2	NA
Ambulance garage	NA	NA	3	NA
Biomedical waste holding	2	3	2	2
Bone marrow transplants	2	2	1	NA
Burn patient care rooms	2	2	2	NA
Business office/administration	4	4	4	4
Central sterile room	3	2	2	2
Class A surgical procedures	3	3	2	3
Class B surgical procedures	2	2	2	2
Class C surgical procedures	1	1	1	1
Critical care rooms (Category 1 room)	2	2	2	2
Emergency department trauma room	2	2	2	2
Intensive care	2	2	2	2
Medical-gas storage room	2	2	2	NA
Medical records	4	4	4	4
Morgue	3	3	2	NA
Occupation therapy	4	4	4	4
Oxygen transfilling	2	2	2	NA
PACU	2	2	2	2
Patient education	4	4	4	4
Pharmacy	2	2	2	2
Physical therapy	4	4	4	4
Protective environment room	2	2	2	NA
Radiology	2	2	2	2
Speech therapy	4	4	4	4
Waiting rooms	4	4	4	4

NA: Not applicable

Note: This is a sample table. The numbers represented in this table might not be consistent with the health care facility scenario.

**A.9.3.6** A source for determining acceptable noise criteria is the ASHRAE Handbook.

**A.9.3.7.3** Paragraph 9.3.7.3 only covers fluids that are stored in enclosed spaces.

**A.9.3.7.5.1** Table A.9.3.7.5.1 shows the cylinder volumes and weights of typical medical gas cylinders.

**A.9.3.10.3.1** During operation, EPS and related equipment reject considerable heat that needs to be removed by proper ventilation or air-cooling. In some cases, outdoor installations rely on natural air circulation, but enclosed installations need properly sized, properly positioned ventilation facilities, to prevent recirculation of cooling air. The optimum position of air-supply louvers and radiator air discharge is on opposite walls, both to the outdoors. [110: A.7.7.1]

**A.9.3.11** Another source of acceptable ventilation rates during construction would be FGI *Guidelines for Design and Construction of Health Care Facilities*.

**A.10.1** An appliance that yields erroneous data or functions poorly is potentially harmful. Quality and assurance of full appliance performance is not covered, except as it relates to direct electrical or fire injury to patients or personnel.

The material in this annex, as it relates to electrical safety, interprets some of the basic criteria by presenting different

methodologies and alternative procedures to achieve the level of safety defined by the criteria.

**A.10.2.3.2.4** IEC 60601-1-2, *Medical Electrical Equipment — Part 1-2: General Requirements for Safety — Collateral Standard: Electromagnetic Compatibility — Requirements and Tests*, defines the terms *protective earth conductor* and *functional earth conductor*. A protective earth conductor is relied upon for safety and provides one means of protection from electric shock. A functional earth conductor has no safety function and does not provide a means of protection against electric shock. A double-insulated medical product is permitted (but not required) to have a functional earth conductor that is referred to as a *functional ground conductor*.

**A.10.2.3.6(2)** Whole-body hyperthermia/hypothermia units should be powered from a separate branch circuit.

**A.10.2.3.6(4)** See Chapter 6 for criteria of receptacles.

**A.10.2.3.6(5)** Power taps used in conjunction with an isolated power system are not subject to this requirement.

**A.10.3.1** Visual inspections do not have to be formal or documented by any particular staff member. All staff are expected to be observant of the condition of the equipment they use, including power cord assemblies.

**Table A.9.3.7.5.1 Typical Medical Gas Cylinders' Volume and Weight of Available Contents [All Volumes at 21.1°C (70°F) and 101.325 kPa (14.696 psi)]**

Cylinder Style and Dimensions	Nominal Volume [L (in. <sup>3</sup> )]	Contents	Name of Gas								
			Air	Carbon Dioxide	Helium	Nitrogen	Nitrous Oxide	Oxygen	Mixtures of Oxygen		
									Helium	CO <sub>2</sub>	
B 8.89 × 33 cm (3½ in. O.D. × 13 in.)	1.43 (87)	kPa (psig)		5778 (838)					13100 (1900)		
		L (ft <sup>3</sup> )		370 (13)					200 (7)		
		kg (lb-oz)		0.68 (1-8)					—		
D 10.8 × 43 cm (4¼ in. O.D. × 17 in.)	2.88 (176)	kPa (psig)	13100 (1900)	5778 (838)	11032 (1600)	13100 (1900)	5137 (745)	13100 (1900)	*	*	
		L (ft <sup>3</sup> )	375 (13)	940 (33)	300 (11)	370 (13)	940 (33)	400 (14)	300 (11)	400 (14)	
		kg (lb-oz)	—	1.73 (3-13)	—	—	1.73 (3-13)	—	*	*	
E 10.8 × 66 cm (4¼ in. O.D. × 26 in.)	4.80 (293)	kPa (psig)	13100 (1900)	5778 (838)	11032 (1600)	13100 (1900)	5137 (745)	13100 (1900)	*	*	
		L (ft <sup>3</sup> )	625 (22)	1590 (56)	500 (18)	610 (22)	1590 (56)	660 (23)	500 (18)	660 (23)	
		kg (lb-oz)	—	2.92 (6-7)	—	—	2.92 (6-7)	—	*	*	
M 17.8 × 109 cm (7 in. O.D. × 43 in.)	21.9 (1337)	kPa (psig)	13100 (1900)	5778 (838)	11032 (1600)	15169 (2200)	5137 (745)	15169 (2200)	*	*	
		L (ft <sup>3</sup> )	2850 (101)	7570 (267)	2260 (80)	3200 (113)	7570 (267)	3450 (122)	2260 (80)	3000 (106)	
		kg (lb-oz)	—	13.9 (30-10)	—	—	13.9 (30-10)	—	*	*	
G 21.6 × 130 cm (8½ in. O.D. × 51 in.)	38.8 (2370)	kPa (psig)	13100 (1900)	5778 (838)	11032 (1600)	15169 (2200)	5137 (745)	15169 (2200)	*	*	
		L (ft <sup>3</sup> )	5050 (178)	12300 (434)	4000 (141)	5000 (176)	13800 (487)	6000 (211)	4000 (141)	5330 (188)	
		kg (lb-oz)	—	22.7 (50-0)	—	—	25.4 (56-0)	—	*	*	
H or K 23.5 × 130 cm (9¼ in. O.D. × 51 in.)	43.6 (2660)	kPa (psig)	15169 (2200)	5778 (838)	15169 (2200)	15169 (2200)	5137 (745)	15169† (2200†)	*	*	
		L (ft <sup>3</sup> )	6550 (231)	15840 (559)	6000 (212)	6400 (226)	15800 (558)	6900 (244)	6000 (212)	15840 (559)	
		kg (lb-oz)	—	29.1 (64)	—	—	29.1 (64)	—	*	*	

Notes: These are computed contents based on nominal cylinder volumes and rounded to no greater variance than ±1 percent.

\* The pressure and weight of mixed gases will vary according to the composition of the mixture.

†275 ft<sup>3</sup>/7800 L cylinders at 2490 psig are available upon request.

Source: Compressed Gas Association, Inc.

**A.10.3.2** There are several methods for measuring ground-wire resistance accurately. Three examples are described as follows and shown in Figure A.10.3.2(a) through Figure A.10.3.2(c):

- (1) *Two-Wire Resistance Technique.* A known current is fed through the unknown resistance. A high-input-impedance voltmeter measures the voltage drop across the resistance, *R*, and *R* is calculated as voltage divided by impedance, *V/I*.

This technique measures the lead resistance in series with the unknown resistance. When the unknown resistance is a ground wire (less than 0.15 ohm), the lead resistance is appreciable. This is accounted for by shorting the lead wires together and “zeroing” the voltmeter. The actual resistance, in effect, subtracts out the lead wire resistance. In order for this technique to be reasonably accurate for measuring ground wires, an active high-impedance millivoltmeter has to be used.

- (2) *Four-Wire Resistance Technique.* This technique is very similar to the two-wire resistance technique. The difference is that the known current is fed to the resistance to be measured through a pair of leads separate from the pair of leads to the voltmeter. The voltmeter is measuring the true voltage across the resistance to be measured, regardless of the resistance of the measuring leads. This method eliminates the need for zeroing out the measuring lead resistance.
- (3) *AC Current Method.* This technique utilizes a step-down transformer of known voltage output to feed current through the ground wire and measure the current that flows. The impedance of the ground wire is then calculated by Ohm's law.

Note that the internal impedance of the measuring circuit has to be established with the test leads shorted. This value needs to be subtracted from the test measurement.

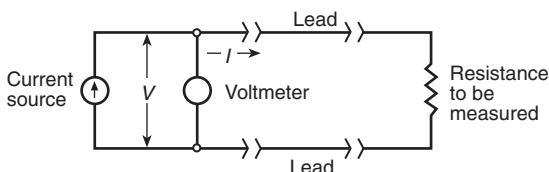


FIGURE A.10.3.2(a) Two-Wire Resistance Technique.

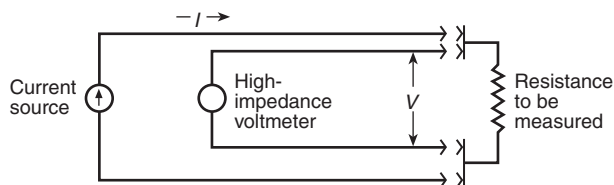


FIGURE A.10.3.2(b) Four-Wire Resistance Technique.

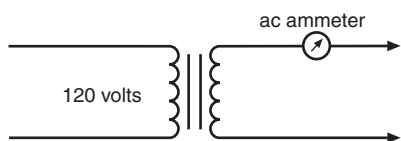


FIGURE A.10.3.2(c) AC Current Method.

**A.10.3.3** For complex leakage current waveforms, a single reading from an appropriate metering system can represent the physiologically effective value of the composite waveform, provided that the contribution of each component to the total reading is weighted in accordance with 10.3.3.

This weighting can be achieved by a frequency response-shaping network that precedes a flat-response meter, or by a meter whose own frequency response characteristic matches that of 10.3.3.

If the required performance is obtained by a meter with integral response-shaping properties, then that meter should have a constant input resistance of 1000 ohms. (A high-input-impedance meter can be used by shunting a 1000 ohm resistor across the meter's input terminals.)

If, however, the required frequency response is obtained by a network that precedes an otherwise flat-response meter, then the input impedance of the network should be 1000 ohms  $\pm$  10 per-

cent, over the frequency range from 0 to 1 MHz, and the frequency response of the network-meter combination should be substantially independent of the impedance of the signal source.

For maximum chassis leakage current permitted (i.e., 300  $\mu$ A) below 1 kHz, this network will yield the limiting current of 10 mA above 30 kHz.

A suggested input network is shown in Figure A.10.3.3.

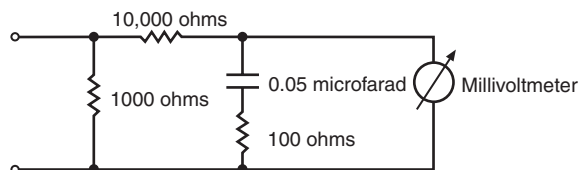


FIGURE A.10.3.3 Leakage Current Measurements (1.0 Millivoltmeter Reading Corresponds to Input Current of 1.0 Microampere).

**A.10.3.3.3** This test is not valid when performed on the load side of an isolation transformer or an isolated power system, because the values obtained will be falsely low.

**A.10.3.3.4** The limits for nonsinusoidal periodic, modulated, and transient waveforms remain to be determined.

For complex leakage current waveforms, a single reading from an appropriate metering system can represent the physiologically effective value of the composite waveform, provided that the contribution of each component to the total reading is weighted in accordance with 10.3.3.4. This weighting can be achieved by a frequency response-shaping network that precedes a flat-response meter, or by a meter whose own frequency response characteristic matches that of 10.3.3.4.

**A.10.3.5.1** Where existing equipment exceeds 500  $\mu$ A, methods to reduce leakage current, such as the addition of small isolation transformers to that equipment, or methods that provide equivalent safety by adding redundant equipment ground are permissible.

**A.10.3.6** Although the chassis leakage current value is 300  $\mu$ A, patient lead leakage current limit for nonisolated input has been intentionally limited to 100  $\mu$ A. This decision is in recognition of the need for a greater level of electrical safety for those portions of devices that make direct electrical patient connection.

**A.10.5.2.5** Systems should comply with the appropriate medical device or system standards such as ANSI/AMMI ES60601-1, *Medical Electrical Equipment*, and IEC 60601-1-1, *Medical Electrical Equipment — Part 1: General Requirements for Basic Safety and Essential Performance*. Consideration should also be given to the guidance provided as part of the documentation supplied with the individual medical equipment.

**A.10.5.4.5** The use of electrical equipment in spaces where there is a high oxygen content is a matter of concern because of the fire hazard. It is particularly a problem where the oxygen is "pure," that is, 80 percent to 90 percent, because materials that are not very flammable in ordinary air become extremely flammable in pure oxygen.

In medical practice, particularly in surgery, patients are often given supplemental oxygen via respirator, anesthesia machines, and so forth. Such supplemental oxygen can range

from room air to 100 percent oxygen. Clearly, different levels of protection are needed.

This code addresses the problem by defining the following three elements of the situation:

- (1) *Type of Air.* An oxygen-enriched atmosphere (OEA) is air that ranges from slightly enriched (23.5 percent, rather than 21 percent) to total oxygen (100 percent).
- (2) *Type of Apparatus.* Oxygen delivery equipment (ODE) is a device that delivers an OEA to a patient.
- (3) *Type of Space.* A site of intentional expulsion (SIE) is a small-volume space where oxygen that has been delivered to the patient is discharged to the ambient air.

When an OEA is within ODE, it is much more likely to have a high concentration of oxygen. Paragraph 10.5.4 therefore advises manufacturers, and A.10.5.4.5 advises users, of precautions to take to reduce the fire hazard. Paragraph 10.5.4 lists four ways of attacking the problem. Note that an OEA can be created not only in a ventilator or oxygen tubing, but also in an oxygen tent or incubator. Special precautions should be taken.

At the other extreme of hazard is a space in the open air, the site of intentional expulsion (SIE). This space is defined as located within 30.5 cm (12 in.) of the exhaust port, because, in most instances, dilution to ambient levels occurs within a few inches of the port; 30.5 cm (12 in.) provides an adequate safety factor. Paragraph 10.5.4.1 provides guidance to minimize this hazard by requiring that only those parts of the apparatus that are intended to be within the SIE are to be of concern. Even these components, such as nurse call buttons, leads, and so forth, do not necessarily need to be listed for use in OEA, because they usually conform to provisions of 10.5.4.1(4); that is, they do not have hot surfaces, and they meet the requirements of Figure 10.5.4.1(a) through Figure 10.5.4.1(f).

The intent of A.10.5.4.5 is to advise users to specify appliances that meet higher requirements where the hazard is higher but not to overspecify where the hazard is minimal. Thus, as they are ordinarily used, nurse call buttons, pillow speakers, and so forth, do not need to be listed for use in oxygen-enriched atmospheres.

Note, however, that these requirements apply only to the intended use. The user should exercise vigilance to guard against an unintended use or an accidental failure, which can vastly increase the hazard.

**A.10.5.4.6** Where possible, combustible materials such as hair, fabric, and paper should be removed from the vicinity where the energy is delivered. Water-soluble surgical jelly has been shown to dramatically reduce the combustibility of such materials.

**A.10.5.5.1** As a guideline, 500  $\mu$ A is recommended as the maximum allowable leakage current limit for laboratory equipment.

One reason for requiring testing of all electrical equipment used in the laboratory is to provide minimum assurance against electrical macroshock hazards.

**A.10.5.5.2** Most laboratory fires involve biomedical or other electronic equipment failures. The most common ignition factors are short circuits or ground faults. Electrical wire or cable insulation is the material most likely to first ignite in a clinical laboratory fire. (See Hoeltge, G.A., Miller, A., Klein, B.R., Hamlin, W.B., "Accidental fires in clinical laboratories.")

**A.10.5.6.2** Although several approaches to documentation exist in hospitals, the minimum acceptable documentation should identify what was tested, when it was tested, and whether it performed successfully. Adopting a system of exception reporting can be the most efficient form of record keeping for routine re-

checks of equipment or systems, thereby minimizing technicians' time in recording the value of each measurement taken. For example, once a test protocol is established, which simply means testing the equipment or system consistent with Chapter 10, the only item (value) that needs to be recorded is the failure or the deviation from the requirements of the chapter that was detected when a corrective action (repair) was undertaken. This approach can serve to eliminate, for example, the need to keep individual room sheets to record measured results on each receptacle or to record measurement values of all types of leakage current tests.

**A.10.5.8.1** "Personnel" includes physicians, nurses, nursing assistants, engineers, and technicians.

**A.11.1.1** Respiratory therapy is an allied health specialty employed with medical direction in the treatment, management, control, diagnostic evaluation, and care of patients with deficiencies and abnormalities of the cardiopulmonary system. (Courtesy of the American Association for Respiratory Therapy, 1720 Regal Row, Dallas, TX 75235.)

Respiratory therapy includes the therapeutic use of the following: medical gases and administration apparatus, environmental control systems, humidification, aerosols, medications, ventilatory support, bronchopulmonary drainage, pulmonary rehabilitation, cardiopulmonary resuscitation, and airway management. (Courtesy of the American Association for Respiratory Therapy, 1720 Regal Row, Dallas, TX 75235.)

There is a continual need for human diligence in the establishment and maintenance of safe practices for respiratory therapy. It is essential for personnel having responsibility for respiratory therapy to establish and enforce appropriate programs to fulfill the provisions of this chapter.

It is the responsibility of the administrative and professional staff of a hospital, or safety director, if one is appointed, to adopt and enforce appropriate regulations for a hospital. In other health care facilities, responsibility could be assigned to a safety director, or other responsible person, who is, in turn, responsible to the administration.

In institutions having a respiratory therapy service, it is recommended that this service be directly responsible for the administration of Chapter 11. Hazards can be mitigated only when there is continual recognition and understanding.

**A.11.1.3** See Chapter 14.

**A.11.2.8** It is particularly important that the intermixing of oxidizing and flammable gases under pressure be scrupulously avoided. Such mixing can result in a violent explosion.

**A.11.3.1** See Table A.11.3.1.

**A.11.3.2** When determining the volume of storage, do not consider cylinders and containers that are in use. There is no limit on the amount of nonflammable gas cylinders or containers that can be stored within a smoke compartment, provided nonflammable gas cylinders and containers in excess of 300 ft<sup>3</sup> are stored in an enclosure that meets the requirements of 11.3.2.1 through 11.3.2.3.

**A.11.4.1.1** If the sole source of supply of nonflammable medical gases, such as nitrous oxide and oxygen, is a system of cylinders attached directly to, and supported by, the device (such as a gas anesthesia apparatus) used to administer these gases, it is recommended that two cylinders of each gas be attached to the administering device.

**Table A.11.3.1 Typical Medical Gas Cylinder Volume and Weight of Available Contents [All Volumes at 21.1°C (70°F)]**

Cylinder Style and Dimensions	Nominal Volume (in. <sup>3</sup> /L)	Contents	Gas									
			Air	Carbon Dioxide	Cyclopropane	Helium	Nitrogen	Nitrous Oxide	Mixtures of Oxygen			
									Oxygen	Helium	CO <sub>2</sub>	
B 3½ in. O.D. × 13 in. 8.89 × 33 cm	87/1.43	psig		838	75					1900		
		L		370	375					200		
		lb-oz		1-8	1-7¼					—		
		kg		0.68	0.66					—		
D 4½ in. O.D. × 17 in. 10.8 × 43 cm	176/2.88	psig	1900	838	75	1600	1900	745	1900	*	*	
		L	375	940	870	300	370	940	400	300	400	
		lb-oz	—	3-13	3-5½	—	—	3-13	—	—	*	*
		kg	—	1.73	1.51	—	—	1.73	—	—	*	*
E 4½ in. O.D. × 26 in. 10.8 × 66 cm	293/4.80	psig	1900	838		1600	1900	745	1900	*	*	
		L	625	1590		500	610	1590	660	500	660	
		lb-oz	—	6-7		—	—	6-7	—	—	*	*
		kg	—	2.92		—	—	2.92	—	—	*	*
M 7 in. O.D. × 43 in. 17.8 × 109 cm	1337/21.9	psig	1900	838		1600	2200	745	2200	*	*	
		L	2850	7570		2260	3200	7570	3450	2260	3000	
		lb-oz	—	30-10		—	—	30-10	122	—	*	*
		kg	—	13.9		—	—	13.9	—	—	*	*
G 8½ in. O.D. × 51 in. 21.6 × 130 cm	2370/38.8	psig	1900	838		1600		745		*	*	
		L	5050	12,300		4000		13,800		4000	5330	
		lb-oz	—	50-0		—		56-0		—	*	*
		kg	—	22.7		—		25.4		—	*	*
H or K 9¼ in. O.D. × 51 in. 23.5 × 130 cm	2660/43.6	psig	2200			2200	2200	745	2200†			
		L	6550			6000	6400	15,800	6900			
		lb-oz	—			—	—	64	244			
		kg	—			—	—	29.1				

Notes: These are computed contents based on nominal cylinder volumes and rounded to a variance not greater than ±1 percent.

\* The pressure and weight of mixed gases will vary according to the composition of the mixture.

†275 ft<sup>3</sup>/7800 L cylinders at 2490 psig are available upon request.

Source: Compressed Gas Association, Inc.

**A.11.4.1.2** The Pin-Index Safety System consists of a combination of two pins projecting from the yoke assembly of the apparatus and so positioned as to fit into matching holes drilled into the cylinder valves. It is intended to protect against the possibility of error in attaching the flush-type valves, with which gas cylinders and other sources of gas supply are equipped, to gas apparatus having yoke connections.

**A.11.4.1.4** Fabrication specifications are contained in CGA V-1 (ANSI B57.1), *Standard for Compressed Gas Cylinder Valve Outlet and Inlet Connections*. Connection No. 860, shown in that document, illustrates the system. Connection No. 870 (Oxygen, Medical), Connection No. 880 (Oxygen–Carbon Dioxide Mixture), Connection No. 890 (Oxygen–Helium Mixture), Connection No. 900 (Ethylene), Connection No. 910 (Nitrous Oxide), Connection No. 920 (Cyclopropane), Connection No. 930 (Helium), and Connection No. 940 (Carbon Dioxide) are for specific medical gases and gas mixtures and utilize the basic dimensions of Connection 860.

**A.11.4.3.3** For example, ozone sterilizers using medical grade oxygen from the piped distribution system should meet the following requirements:

- (1) Not be permanently attached to the piped distribution system
- (2) Be a medical device that has been listed for the intended purpose with the United States Food & Drug Administration
- (3) Operate at or below 5 psig (34.5 kPa)

**A.11.5.1.1.2** Patients and hospital personnel in the area of administration should be advised of respiratory therapy hazards and regulations.

Visitors should be cautioned of these hazards through the prominent posting of signs. (See 11.3.4.)

**A.11.5.1.1.3** Such toys have been associated with fire incidents in health care facilities.

A suggested text for precautionary signs for oxygen tent canopies and oxygen hoods used in pediatric nursing units is the following:

**CAUTION: OXYGEN IN USE  
ONLY TOYS APPROVED BY  
NURSES MAY BE GIVEN TO CHILD**

**A.11.5.2.1.1** “Personnel” typically includes physicians, nurses, nursing assistants, respiratory therapists, engineers, technicians, and others.

**A.11.5.3.2** Precautionary signs should be at least 21 cm × 28 cm (8 in. × 11 in.).

Any material that can burn in air will burn more rapidly in the presence of oxygen.

Special signs and additional precautionary measures should be employed whenever foreign languages present a communication problem. (See Figure A.11.5.3.2.)



**FIGURE A.11.5.3.2 Suggested Minimum Text for Precautionary Signs.**

No electrical equipment is permitted within an oxygen enclosure or within 1.5 m (5 ft) of the enclosure.

**A.11.7.3.1** The seller has a responsibility to provide written instructions to the user in accordance with 11.7.2. In fulfilling this responsibility, the seller should explain to the user the use of the equipment being delivered and precautions that are to be taken. The seller’s written instructions are intended to make the user aware of the hazards of the material and to provide recommendations that will address the location, restraint, movement, and refill of ambulatory containers when these containers are to be refilled by the user. However, the user has the responsibility to receive, read, and understand the written material regarding storage and use of liquid oxygen and the containers and equipment that are furnished by the seller. In addition to specific information or instructions provided by the seller or equipment manufacturer regarding the storage or use of the equipment and of the liquid oxygen or the containers used, the user remains responsible to see that the containers are used or maintained in accordance with the seller’s instructions to ensure that they are as follows:

- (1) Located and maintained in accordance with the requirements of 11.7.3.2
- (2) Restrained in accordance with the requirements of 11.7.3.3
- (3) Handled or transported in accordance with the requirements of 11.7.3.4
- (4) Refilled in accordance with the requirements of 11.7.3.5 and the manufacturer’s instructions when liquid oxygen ambulatory containers are to be refilled by the user

**A.11.7.3.3** Two points of contact can be provided by using elements of a room or furnishings in the room, such as the walls of a corner of a room, or a wall and a furnishing or object, such as a table or a desk.

**A.11.7.3.5.1.1** Drip pans or similar containment devices are used in order to protect against liquid oxygen spillage coming into contact with combustible surfaces, including asphalt, which would elevate the potential for ignition.

**A.12.1** Such facilities include, but are not limited to, hospitals, convalescent or nursing homes, and emergency receiving stations. A government authority could formally designate such facilities as disaster treatment centers. Such facilities would not normally include doctors’ or dentists’ offices, medical laboratories, or school nurseries, unless such facilities are used for treatment of disaster victims. National bioterrorism preparedness efforts call for the use of schools and other large public facilities to provide facilities for mass immunization.

**A.12.1.1** Throughout this chapter, wherever the term *hospital* is used, the term should also apply to other types of health care facilities. Applicable facilities include, but are not limited to, hospitals, convalescent or nursing homes, and emergency receiving stations. A government authority could formally designate such facilities as disaster treatment centers. Such facilities would not normally include doctors’ or dentists’ offices, medical laboratories, or school nurseries, unless such facilities are used for treatment of disaster victims. National bioterrorism preparedness efforts call for the use of schools and other large public facilities to provide facilities for mass immunization. An emergency management program (formerly known as a disaster plan or internal/external plan) encompasses activities across four phases: mitigation, preparedness, response, and recovery. Mitigation activities are those designed to reduce or eliminate the impact of hazards. Preparedness activities include those that build organizational and individual capabilities to deal with disasters. Response activities include all necessary actions to stop ongoing negative effects of a disaster. Recovery activities are those that restore the organization, its employees, and the community back to normal.

The Joint Commission has incorporated Comprehensive Emergency Management Plan, Annex G for The Joint Commission publications.

*NFPA 1600, Standard on Disaster/Emergency Management and Business Continuity Programs*, is an internationally accepted framework for an emergency program. NFPA 99, Chapter 12, recognizes this overall structure and provides additional information useful to health care organizations. Table A.12.1.1 illustrates the relationship between the elements of NFPA 99, Chapter 12, and *NFPA 1600*.

**A.12.2.1** In time of disaster, all persons are subject to certain constraints or authorities not present during normal circumstances. The emergency operations plans written by a health care facility should be reviewed and coordinated with such authorities so as to prevent confusion. Such authorities include, but are not limited to, civil authorities (such as a fire department, a police department, a public health department, or emergency medical service councils), Centers for Disease Control, Federal Bureau of Investigation, and emergency management or military authorities. See Comprehensive Emergency Plan, Annex G for publications explaining how the out-of-hospital response is organized to multiple and mass casualty incidents. Further, an authority having jurisdiction can impose upon the senior management of the facility the responsibility for participating in a community emergency management program.



**Table A.12.1.1 How NFPA 99, Chapter 12, Relates to NFPA 1600**

NFPA 1600	NFPA 99, Chapter 12
Introduction	—
Scope	12.1.2 Applicability
Purpose	12.1.1.1 Framework
Program Management	—
Policy	12.2.1 Authority Having Jurisdiction
Program Coordinator	12.2.2 Senior Management
Program Committee	12.2.3 Emergency Management Committee
Program Assessment	12.2.3 Emergency Management Committee
Program Elements	12.5.3 Program Elements
General	—
Laws and Authority	—
Hazard Identification and Risk Management	A.12.5.3.1.2 Hazard Identification
Hazard Management (Mitigation)	12.5.3.2 Mitigation
Resource Management	12.5.3.3.6.2 Resource Assessment
Planning	12.5.3.3.5 Emergency Operations Plan
Direction, Control, and Coordination	A.12.2.3.3 Incident Command System
Communications and Warning	A.12.5.3.3.6.1(5) Communications
Operations and Procedures	A.12.5.3.3.6.3 Identification of Personnel
	12.5.3.3.6.5 Essential Utilities
	12.5.3.3.6.7 Staff Roles
	12.5.3.4.12 Surge Capacity of Victims
	12.5.3.3.6.3 Safety and Security
	12.5.3.5 Recovery
Logistics and Facilities	12.5.3.4 Response
Training	12.5.3.3.7 Staff Education
Exercises, Evaluations, and Corrective Actions	12.5.3.3.8 Testing Emergency Plans and Operations
Public Education and Information	—
Finance and Administration	—

**A.12.2.3** It is strongly recommended that medical leadership representatives play a key role in the emergency management committee and planning process. The following list is not intended to be all-inclusive, and additional representatives might be needed based on the level of care provided or the structure of the organization:

- (1) Bioterrorism coordinator
- (2) Communications/data management
- (3) Finance
- (4) Human resources
- (5) Legal/risk management
- (6) Public relations
- (7) Purchasing/materials management
- (8) Quality management
- (9) Training and education

**A.12.2.3.3** Federal, state, and local governments are required to use an incident command system (ICS) based on the National Incident Management System (NIMS). Although private sector hospitals are not required to be NIMS compliant, many are choosing to comply, not only to integrate with other emergency responders but also to remain eligible to receive certain federal grant monies. HICS, the Hospital Incident Command System, was specifically designed to be NIMS compliant, and, therefore, many hospitals use this model, either as developed or with some customization. HICS can be customized and adapted to other types of health care facilities.

HICS is led by an incident commander and assisted by command staff consisting of the public information officer, safety officer, and liaison officer, and those medical/technical specialists who are appropriate to the event. Section chiefs are responsible for each of the following sections:

- (1) Operations Section: Conducts the tactical operations to carry out the incident action plan using defined objectives and directing all necessary resources
- (2) Planning Section: Collects and evaluates information for decision support, maintains resource status information, prepares the Incident Action Plan, and maintains documentation
- (3) Logistics Section: Provides support, resources, and other services to meet the operational objectives
- (4) Finance/Administration: Monitors costs related to the incident and provides accounting services, time recording, and cost analyses

Each section is composed of subordinate positions that are divided into branches or units.

Features of HICS include the following:

- (1) Clear chain of command
- (2) Manageable span of control
- (3) Common terminology
- (4) Adaptability to unified command

HICS tools include the following:

- (1) Job action sheets detailing position responsibilities
- (2) Forms to document the event

HICS was intended to be used not only for emergencies but also for planned events. Complete HICS documentation is free and available for download at [www.emsa.ca.gov](http://www.emsa.ca.gov).

**A.12.5.3.1.2** By basing the planning of health care emergency management on realistic conceptual events, the program reflects those issues or events that are predictable for the environment in which the organization operates. Thus, such conceptual planning should focus on issues, such as severe weather typical in the locale, situations that can occur due to close proximity of industrial or transportation complexes, or earthquake possibilities due to local seismic activity. Planning should also incorporate knowledge available in the emergency management research about how individuals, small groups, organizations, communities, and societies behave during emergencies.

**A.12.5.3.1.3(1)** Continuity of operations can include, but is not limited to, maintaining staffing levels, resources and assets, ability to obtain support from the outside environment, and leadership sustainability.

**A.12.5.3.3.6.1(5)** Emergency internal and external communications systems should be established to facilitate communication with security forces and other authorities having jurisdiction, as well as internal patient care and service units in the

event normal communications methods are rendered inoperative. The basic form of communication in a disaster is the telephone system. As part of the contingency plan to maintain communication, a plan for restoring telephone systems or using alternate systems is necessary. Typically, the first line of internal defense for a system outage is strategically placed power-failure telephones that are designed to continue to function in the event of system failure (e.g., dedicated lines, fax lines). Plans for external outages and load control should include the use of pay phones, where available, that have first priority status in external system restoration. Facilities should preplan restoration activities and prioritization with their telephone service providers. A review with the state and other communications agencies (Government Emergency Telecommunications Service, Wireless Priority Service, Health and Homeland Alert Network) should be conducted.

Contingency plans should also contain strategies for the use of radio frequency communications to supplement land-line usage. The plan should include a means to distribute and use two-way radio communication throughout the facility. A plan for the incorporation and use of amateur radio operators should also be considered.

It should be recognized that single-channel radio communication is less desirable than telephone system restoration due to the limited number of messages that can be managed. Cellular telephones, although useful in some disaster situations, should not be considered a contingency that has high reliability due to their vulnerability to the load control schemes of telephone companies. Portable e-mail devices, satellite telephones, and audio and video-conferencing services are useful tools to link key staff and organizations.

**A.12.5.3.3.6.3** Prior to a disaster, facilities should formally coordinate their security needs with local law enforcement agencies. The health care institution will find it necessary to share its emergency operations plans with local law enforcement agencies or, better still, involve them in the process of planning for security support during disasters. The information should at least include availability of parking for staff, patients, and visitors, and normal vehicular, emergency vehicular, and pedestrian traffic flow patterns in and around the facility. The extent of the security and traffic control problems for any given health care facility will depend upon its geographical location, physical arrangement, availability of visitor parking areas, number of entrances, and so forth.

*Crowd Control.* Visitors can be expected to increase in number with the severity of the disaster. They should not be allowed to disrupt the functioning of the facility disaster plan. Ideally, a visitor reception center should be established away from the main facility itself, particularly in the case of major disasters. Volunteer personnel such as community emergency response teams (CERT), Red Cross, Explorer Scouts, or other helpers can be utilized as liaisons between the visitors and the health care facility itself.

*Vehicular Traffic Control.* Arrangement for vehicular traffic control into and on the facility premises should be made in the disaster planning period. It will be necessary to direct ambulances and other emergency vehicles carrying casualties to triage areas or the emergency room entrance, and to direct incoming and outgoing vehicles carrying people, supplies, and equipment. Charts showing traffic flow and indicating entrances to be used, evacuation routes to be followed, and so forth, should be prepared and included in the emergency operations plan. Parking arrangements should not be overlooked.

*Internal Security and Traffic Control.* Internal security and traffic control are best conducted by facility-trained personnel (i.e., regular health care facility security forces) with reinforcements as necessary. Potential additional assistance from the local law enforcement agencies should be coordinated in the disaster planning phase. Upon activation of the emergency operations plan, security guards should be stationed at all unlocked entrances and exits to the extent possible. Entrance to the facility should be restricted to personnel bearing staff identification cards and to casualties. In the case of major access corridors between key areas of the facility, pedestrian traffic should be restricted to one side of the corridor, keeping the other side of the corridor free for movement of casualties. Traffic flow charts for internal traffic should also be prepared in the planning phase, as is the case with external traffic control.

**A.12.5.3.3.6.5** Consideration should be given to preemptively installing parallel components such that maintenance can be performed on operating equipment. This will necessitate the installation of additional valves, circuits, or controls to isolate those parts to be removed and replaced, such as air or fuel filters. This work should not violate any other code, standard, or safety device. The desired outcome is system resiliency despite part failure.

**A.12.5.3.3.6.8(1)** The command structure should also follow the National Incident Management System (NIMS) as provided in *NFPA 1600, Standard on Disaster/Emergency Management and Business Continuity Programs*.

**A.12.5.3.3.8** Experiences show the importance of drills to rehearse the implementation of all elements of a specific response, including the entity's role in the community, space management, staff management, and patient management activities. To document an exercise, the following aspects are typically incorporated. A general overview of the scenario, documented activation of the emergency operations plan, reports from an identified evaluator(s), evaluation of all involved participants (departments) and any observer(s), a written critique following the drill, and any identified follow-up training or improvement action(s) to correct or manage any deficiencies.

**A.12.5.3.3.9.9** When improvements require substantive resources that cannot be accomplished by the next planned exercise, interim improvements should be put in place until final resolution.

**A.12.5.3.4.1** In emergency situations that occur without warning and impact the facility, staff at the scene of the problem are expected to follow established protocols to protect life, notify others, and conserve property. Senior management can establish a hospital command center (HCC) or participate in unified command with other responding agencies at a designated emergency operations center (EOC). In emergency situations with warning or whose impacts require extended periods to resolve, designated leadership reports to the HCC. Not all incidents require an HCC.

The HCC provides centralized locations for information collection, display, coordination, documentation, and dissemination.

**A.12.5.3.4.5** Note that care should be taken to ensure that identification cards are recalled whenever personnel terminate association with the health care facility. Members of the news media should be asked to wear some means of identifica-

tion, such as a press card, on their outside garments so that they are readily identifiable by security guards controlling access to the facility or certain areas therein. Clergy also will frequently accompany casualties or arrive later for visitations and require some means of identification. Water storage systems should be inventoried and protected to the greatest extent possible.

**A.12.5.3.5** Recovery measures could involve a simple repositioning of staff, equipment, supplies, and information services; or recovery could demand extensive cleanup and repair. It can, under certain circumstances, be a means to identify opportunities for structural and nonstructural mitigation efforts. Filing of loss claims might require special approaches. Health care facilities should have access to cash or negotiable instruments to procure immediately needed supplies.

**A.13.1** This chapter is the source for security management in health care facilities and is based on the foundations of NFPA 730, *Guide for Premises Security*.

**A.13.1.1** A health care facility security plan can be formulated from security-sensitive areas that need the highest level of protection outward to the perimeter of the health care facility campus in concentric rings. Viewed from the outside, security is thus open and welcoming to patients and visitors. As an individual proceeds into the interior, public spaces might have minimal surveillance, but those sensitive areas that cannot be entered are layered with protections and countermeasures.

**A.13.1.2** The security plan should be reviewed annually or more frequently if new challenges present themselves.

**A.13.2.1** For general information regarding the SVA and premises security, see NFPA 730, *Guide for Premises Security*.

**A.13.3.2(3)(c)** The emergency potential inherent in the telephoned bomb threat warrants inclusion of this contingency in the health care emergency operations plan. Experience has shown that facility personnel have to accompany police or military bomb demolition personnel in searching for the suspected bomb, because speed is of the essence, and only individuals familiar with a given area can rapidly spot unfamiliar or suspicious objects or conditions in the area. This is particularly true in health care facilities. The facility switchboard operator has to be provided with a checklist, to be kept available at all times, in order to obtain as much information as possible from the caller concerning the location of the supposed bomb, time of detonation, and other essential data, which have to be considered in deciding whether or not to evacuate all or part of the facility.

**A.13.4.2(1)** A visible presence is normally accomplished by the placement of a security officer at the ambulance entrance. This serves the dual purpose of monitoring the security cameras throughout the emergency department as well as the activity at the ambulance entrance.

**A.13.4.3(5)** The facility-wide alerting system should be activated for all reports of pediatric or infant abduction. The use of a standardized “code alert” system can facilitate the announcement; for example, “code pink” for an infant abduction or “code purple” for a pediatric abduction.

**A.13.4.4** Video surveillance and motion detection can be used as additional protection for these areas. Some controlled drugs might need to be stored in safes.

**A.13.4.6(3)** Reasons for a contraband check procedure would be to control items such as tobacco, drugs, or tools that could cause harm to the patient or staff.

**A.13.4.7(1)** Law enforcement personnel should have orientation on the emergency procedures and layout of the facility. There should be good communication between law enforcement and health care facility security staff.

**A.13.5.3.1** There can be times where full or partial facility access or egress is not desirable. Planning for these events should be conducted in coordination with local emergency agencies, such as police, fire, and public health agencies.

**A.13.6** Patients that generate media interest should be subject to special security procedures. VIP or media representatives present the need for a unique set of security requirements. Protection of VIPs is normally accomplished by restricting the use of names on charts and rooms and by assigning a dedicated security watch.

Admission of a high-profile person to a health care facility creates two sets of problems that might require partial activation of the health care emergency management plan. These problems are security and the reception of news media.

Provision of security forces in this situation might be provided by a governmental agency or private security forces. However, activation of facility security forces might be required to prevent hordes of curious onlookers from entering facility work areas and interfering with routine facility functioning. Routine visiting privileges and routine visiting hours might need to be suspended in parts of the facility.

**A.13.6.1.1** The marketing department of the hospital might be best suited to assist security personnel with media control.

**A.13.6.2** Ideally, news media personnel should be provided with a media briefing area or a media staging area, or both, with access to telephone communication and, if possible, an expediter who, though not permitted to act as a spokesperson for news releases, could provide other assistance to such personnel. News media personnel should not be allowed into the health care facility without proper identification. Media representatives should be requested to wear some means of identification for security purposes. Members of the news media should be asked to wear some means of identification, such as a press card, on their outside garments so that they are readily identifiable by security guards controlling access to the facility or certain areas therein.

**A.13.7** Crowd control of persons demanding access to care will create additional demands on security. Because of the intense public interest in disaster casualties, news media representatives should be given as much consideration as the situation will allow. To alert off-duty health care staff and to reassure the public, use of broadcast media should be planned.

Where feasible, photo identification or other means to ensure positive identification should be used. Visitor and crowd control create the problem of distinguishing staff from visitors. Such identification should be issued to all facility personnel, including volunteer personnel who might be utilized in disaster functions. Note that care should be taken to ensure that identification cards are recalled whenever personnel terminate association with the health care facility. Clergy also will frequently accompany casualties or arrive later for visitations and require some means of identification.

**A.13.8.3** Facility keys should not be identified in any manner such that a person finding a lost key could trace it back to the facility. A policy should be established to restrict duplication of keys without written permission. All keys should be marked “DO NOT DUPLICATE” to deter the unauthorized copying of keys.

There should be a log of keys issued to employees and vendors maintained at the facility. A responsible individual should be in charge of issuing keys and maintaining complete, up-to-date records of the disposition of keys, including copies. The records should show the issuance and return of keys, including the name of the person to whom the key was issued, as well as the date and time. Records of key issuance should be secured and kept separate from keys.

Keys should be restricted to those who need them, and extra copies of keys should be kept locked in a secure cabinet with access control.

Procedures should be established for collecting keys from terminated employees, employees on vacation, and vacated tenants. Lost keys should be reported immediately and procedures established for the rekeying or replacement of the affected locks.

A master key system should be designed so that the grandmaster key is the only key that will open every restricted area of the facility. A master key system is used to limit the number of keys carried by personnel requiring access to multiple areas of the building. It is important that such a system not be designed so that the loss of a single key could provide an unauthorized individual unrestricted access to all areas of the building. The sophistication of the master key system should depend upon an assessment of employees' or tenants' needs and the criticality, risk, and sensitivity of restricted areas.

The number of grandmaster keys should be limited to the least number necessary for operation of the health care facility. Master key distribution should be limited to the personnel requiring access to multiple restricted areas. A log should be maintained showing who is in possession of master keys.

**A.13.9** Background checks should include criminal record checks, employment histories, and references. This function is typically managed by the human resources department.

**A.13.10** The number of guards needed at any given time will depend on the size of the facility, the hours of operation, and the current risk factors. Many states have laws that require background checks and specific training for security personnel, especially armed personnel. It is essential that facilities using security personnel train them in the legal and practical applications of their employment. Training must reflect changes in regulations and the enactment of new laws.

**A.13.10.1** Post orders should contain a list of the duties of the security officer and instructions to cover all foreseeable events the security officer can encounter. Post orders should list the name of the facility, the date issued, the effective date, and the purpose. Duties of security personnel should be listed, including job classification, uniforms, carrying of firearms, reporting times, watch tours, hours of coverage, and other duties to be assigned. Instructions should be lawful and protect the safety of the security officer and those they encounter. Reviews of post orders should be conducted regularly with facility management and security officers. Post orders should be updated regularly and at least annually. A procedure should be established to inform security officers of changes in post orders.

**A.13.11.1** The effectiveness of the security plan is tested by performing drills. Drills should be conducted on all work schedules. Drills during all shifts are necessary so that all personnel are familiar with the plan. Practicing the plan helps personnel react as needed during a security incident.

**A.14.1** Chapter 14 does not apply to respiratory therapy employing oxygen-enriched atmospheres at ambient pressures. (See Chapter 11.)

**A.14.1.2.2** Chambers designed for animal experimentation but equipped for access of personnel to care for the animals are classified as Class A for the purpose of Chapter 14.

**A.14.2.1.1.1** For guidance on minimum construction requirements, depending on occupancy classification, see NFPA 101, *Life Safety Code*.

**A.14.2.1.1.6** Characteristics of building construction housing hyperbaric chambers and ancillary facilities are no less important to safety from fire hazards than are the characteristics of the hyperbaric chambers themselves. It is conceivable that a fire emergency occurring immediately outside a chamber, given sufficient fuel, could seriously endanger the life or lives of those inside the chamber. Since the service facilities, such as compressors, cooling equipment, reserve air supply, oxygen, and so forth, will, in all probability, be within the same building, these facilities will also need protection while in themselves supplying life-maintaining service to those inside.

**A.14.2.1.2** When the area to be covered is small (six sprinklers or less), 9.7.1.2 of NFPA 101 permits fire sprinkler systems required to be installed in accordance with NFPA 13 to be supplied from the local domestic water system, provided that the local domestic water system has sufficient pressure and flow capacity.

**A.14.2.1.2.2** In addition to the functions of building protection, the chamber room sprinkler system should be designed to ensure a degree of protection to chamber operators and occupants who likely will not be able to immediately evacuate the premises in the event of a fire.

**A.14.2.1.3.1** Hyperbaric chamber systems often require piping materials, pressure ratings, and joining techniques that are not permitted by Chapter 5 of this code.

**A.14.2.2.1** Other chapters in NFPA 99 contain many requirements that could appear to relate to hyperbaric facilities but could be inappropriate. The requirements of other chapters in NFPA 99 should be applied to hyperbaric facilities only where specifically invoked by this chapter.

**A.14.2.2.5** One common hazard of paint fires in ships is related to welding or burning operations on one side of a metal bulkhead that heats the metal to a point where the paint on the opposite side ignites. Most paints are not flammable when installed as thin layers over a substantial heat sink, such as the thick steel walls of a hyperbaric chamber, unless the walls are heated first. The same paints, when ground into a powder or installed over a very thin metal substrate, can burn readily. The paint selected for use in the interior walls of a hyperbaric chamber should be selected both for suitability to the requirements of the application and for its combustibility properties. The hazard of a fire increases as the amount of heat sink is reduced. Therefore, combustion is easier to achieve when paint is applied over thin materials and when there are multiple layers of paint. On thin section materials that are easily heated, care should be exercised in selecting the flammability characteristics of the paint and the amount of paint applied.

**A.14.2.2.5.2** Many commercial sound-deadening materials that might be nonflammable are porous and will absorb water from activation of the fire-suppression system and retain odor. Metallic panels that contain a large quantity of small holes or are made of wire mesh and are installed about 2.5 cm (1 in.) away from the chamber wall can be used to form an acoustic baffle. These panels should be made from corrosive-resistant

materials, such as stainless steel or aluminum, and are permitted to be painted in accordance with 14.2.2.5.1.

**A.14.2.2.6** Prudent design considerations suggest that at least 50 percent excess pass-through capacity be provided, for future use, given the difficulty of adding pass-throughs to the chamber after it is constructed and tested.

**A.14.2.4.1.2** Experience and practice can dictate the need for a threshold ventilation rate in excess of the minimum specified for sanitary reasons. It is recommended that consideration be given, if necessary, to the use of odor filters in the chamber circulation system as a means of keeping sanitary ventilation rate requirements to a minimum.

**A.14.2.4.2.1** If intakes are located where it could be possible for maintenance to be conducted in the immediate vicinity, a warning sign should be posted.

**A.14.2.4.3.2** Subsection 13.3.1 specifies a desirable temperature of 20°C (68°F). It is impractical to maintain such a temperature during pressurization, but efforts should be made in the design and operation of thermal control systems to maintain the temperature as close to 22°C (75°F) as possible. The air-handling system of all Class A chambers should be capable of maintaining relative humidity in the range of 50 percent to 70 percent during stable depth operations.

The thermal control system should be designed to maintain the temperature below 29°C (85°F) during pressurization, if possible, and above 19°C (65°F) during depressurization, if possible.

**A.14.2.4.4.1** Ventilation is permitted to be provided by closed- or open-circuit systems.

**A.14.2.4.5.3** The intent of this requirement is to allow facility staff to evacuate the facility and avoid breathing contaminated air. This requirement is permitted to be met using either a self-contained breathing apparatus, smoke hood with integral filter/air supply, or similar technology.

The number of units available should be adequate to meet facility staffing.

The breathing duration of the personal protection devices should be predicated upon the time necessary for evacuation of the facility.

Facility evacuation time should be determined during fire drills conducted by the hyperbaric facility.

**A.14.2.5.1.4** This requirement does not preclude the use of an alarm system affording direct fire department contact.

**A.14.2.5.1.5** Experience has shown that fire blankets, portable carbon dioxide extinguishers, and other methodology intended to “snuff out” fires by excluding air are not effective in controlling fires in oxygen-enriched atmospheres. Valuable time can be lost in attempting to use such devices.

**A.14.2.5.2.4** More than one control station could be required in a compartment (lock), depending on its size.

**A.14.2.5.2.6** Experience has shown that, when water is discharged through conventional sprinkler heads into a hyperbaric atmosphere, the spray angle is reduced because of increased resistance to water droplet movement in the denser atmosphere. This is so, even though the water pressure differential is maintained above chamber pressure. Therefore, it is necessary to compensate by increasing the number of sprinkler heads. It is recommended that spray coverage tests be conducted at maximum chamber pressure.

Some chamber configurations, such as small-diameter horizontal cylinders, could have a very tiny floor, or even no floor at all. For horizontal cylinder chambers and spherical chambers, the term *floor level* should be taken to mean the level at ¼ diameter below the chamber centerline or actual floor level, whichever yields the larger floor area.

**A.14.2.5.4.2** Additional detectors are recommended to avoid “blind” areas if the chamber contains compartmentation.

**A.14.2.5.5** The primary focus for the semiannual test of a water-based extinguishing system is to ensure water flow through the system (i.e., inspector’s test). Other vitally important benefits are the activation of water flow devices, alarm appliances, and notification and annunciator systems.

**A.14.2.7.1.4.1** It is recommended that system design be such that electric motors not be located inside the chamber.

**A.14.2.7.3** This subsection contains requirements for the safe use of electrical equipment in the hyperbaric, oxygen-enriched environment of the Class A chamber.

**A.14.2.7.3.10** It should be recognized that interruption of any powered circuit, even of very low voltage, could produce a spark sufficient to ignite a flammable agent.

**A.14.2.7.3.11.1** It is recommended that all control switching functions inside the chamber be accomplished using intrinsically safe circuits that control power and control circuits located outside of the chamber.

**A.14.2.7.3.12** It is the intention of 14.2.7.3.12 that equipment used in the chamber be incapable of igniting, by heating, any material or fabric that could come into contact with the surface of the equipment.

**A.14.2.7.3.15** It is strongly recommended that high-intensity local task lighting be accomplished using through-hull fiber-optic lights. Many high-intensity lights will not meet the temperature requirements specified in 14.2.7.3.15.

**A.14.2.7.3.16.1** The requirement for isolation from mains supply in 14.2.7.3.16.1 is not the same as the requirement in 14.2.7.4.2 that circuits supplying power to portable utilization equipment inside the chamber be isolated, monitored, and alarmed.

It is recommended that intrinsically safe sensors and controls be used whenever possible.

**A.14.2.7.3.17** These requirements are only the minimum requirements for electrical safety. There are many other safety concerns that should be addressed on a case-by-case basis. Meeting the requirements of 14.2.7.3.17 does not indicate that proper device performance will occur in the hyperbaric environment and that the device will be safe for use with patients.

**A.14.2.7.5.2** It is necessary that these circuits be protected from exposure to water from the room sprinkler system protecting the chamber housing in the event of a fire in the vicinity of the chamber while it is in operation.

**A.14.2.7.6.1.1** Limiting current using a suitable current sensing device (e.g., a rapid acting fuse or circuit breaker, located outside the chamber) would provide appropriate protection and prevent circuits from exceeding the 4.0 W power limit.

**A.14.2.8.2** Intercommunications equipment is mandatory for safe operation of a hyperbaric facility.

**A.14.2.8.2.1** It is recommended that multiple-compartment (lock) Class A chambers be equipped with multiple channel systems and that, in addition, a sound-powered telephone or surveillance microphone be furnished.

**A.14.2.8.6** The purity of the various gas supplies should be ensured.

A purity statement for any cryogenic or high pressure cylinder gas should be supplied by the vendor.

Gas cylinder purity statements should be cross-referenced, where possible, with the delivered gas.

For additional verification, some facilities have installed sampling ports for monitoring oxygen and other gases.

**A.14.2.8.6.1** The frequency of such monitoring should depend on the location of the air intake relative to potential sources of contamination.

**A.14.2.8.6.2** CGA Grade E permits quantities of hydrocarbons and water in air. In piping systems where air and oxygen might be used interchangeably, hydrocarbon buildup can occur and increase the risk of fire when oxygen is used. There is also a concern about pneumatic components being fouled and functionally impaired by hydrocarbons or water from compressed air. Ideally, there should be no condensed hydrocarbons in an oxygen system and no liquid water in pneumatic control systems.

**A.14.2.8.8** It is recommended that information about the status of an anesthetized or otherwise monitored patient be transmitted to the inside chamber attendants via the intercommunications system. As an alternative, the monitor indicators can be placed adjacent to a chamber viewport (or viewports) for direct observation by inside personnel.

**A.14.2.9.2** Exhaust piping extending from the building can create a lightning risk. Lightning protection should be considered.

**A.14.3.1.2** The hazards involved in the use of hyperbaric facilities can be mitigated successfully only when all of the areas of hazard are fully recognized by all personnel and when the physical protection provided is complete and is augmented by attention to detail by all personnel of administration and maintenance having any responsibility for the functioning of the hyperbaric facility. Since Section 14.3 is expected to be used as a text by those responsible for the mitigation of hazards of hyperbaric facilities, the requirements set forth are frequently accompanied by explanatory text.

**A.14.3.1.3.2** The complexity of hyperbaric chambers is such that one person should be designated chamber operator, such as a person in a position of responsible authority. Before starting a hyperbaric run, this person should record, in an appropriate log, the purpose of the run or test, the duties of all personnel involved, and a statement that he or she is satisfied with the condition of all equipment. Exceptions should be itemized in the statement.

Safety, operational, and maintenance criteria of other organizations are published, for example, in the Undersea & Hyperbaric Medical Society Safety Committee documents and the Compressed Gas Association pamphlets and should be reviewed by the safety director. The safety director should serve on the health care facility safety committee.

Due to a conflict of responsibility, the same individual should not serve as both medical director and safety director.

The term *safety director* is used for convenience. It is the intent of 14.3.1.3.2 to establish a set of safety responsibilities for the responsible person, regardless of the job title.

**A.14.3.1.3.3** It is incumbent upon the governing body to insist that rules and regulations with respect to practices and conduct in hyperbaric facilities, including qualifications and training of hyperbaric personnel, be adopted by the medical or administrative staff of the institution, and that regulations for inspection and maintenance are in use by the administrative, maintenance, and ancillary (and, in the case of a hospital, nursing and other professional) personnel.

In meeting its responsibilities for safe practices in hyperbaric facilities, the administration of the facility should adopt or correlate regulations and standard operating procedures to ensure that both the physical qualities and the operating maintenance methods pertaining to hyperbaric facilities meet the standards set in Chapter 14. The controls adopted should cover the conduct of personnel in and around hyperbaric facilities and the apparel and footwear allowed. They should cover periodic inspection of static-dissipating materials and of all electrical equipment, including testing of ground contact indicators.

**A.14.3.1.3.4** It is recommended that training of hyperbaric chamber personnel be closely monitored, following the guidelines and publications of the Undersea & Hyperbaric Medical Society, the Baromedical Nurses Association, and the National Board of Diving and Hyperbaric Medical Technology.

**A.14.3.1.3.5** In the case of a hyperbaric facility located in a hospital, hospital licensing and other approval bodies, in meeting their responsibilities to the public, should include in their inspections not only compliance with requirements for physical installations in hyperbaric facilities, but also compliance with the requirements set forth in Section 14.3.

**A.14.3.1.4.1** It is recommended that all personnel, including trainees and those involved in the operation and maintenance of hyperbaric facilities, and including professional personnel and (in the case of hospitals) others involved in the direct care of patients undergoing hyperbaric therapy, be familiar with Chapter 14. Personnel concerned should maintain proficiency in the matters of life and fire safety by periodic review of Chapter 14, as well as any other pertinent material.

Positive measures are necessary to acquaint all personnel with the rules and regulations established and to ensure enforcement. Training and discipline are necessary.

**A.14.3.1.4.4.1** All full- and part-time personnel should receive training in emergency management appropriate to their job descriptions.

**A.14.3.1.4.5** A calm reaction (without panic) to an emergency situation can be expected only if the recommendations are familiar to and rehearsed by all concerned.

A suggested outline for emergency action in the case of fire is contained in B.14.2.

**A.14.3.1.5.1.1** Oxygen-filled chambers dump oxygen into the room each time the door is opened at the end of a treatment. Oxygen could also be dumped into the room by the chamber pressure relief device. Air-filled chambers could leak oxygen into the room from the breathing gas piping. This oxygen enrichment lowers the ignition temperature of combustible materials. Therefore, extra caution should be used in the area around the chamber as well as inside the chamber.

**A.14.3.1.5.2.2(2)** Allowable quantities complying with 14.3.1.5.2.2(2) can be determined from the chamber volume, flammable agent vapor density, and lower explosive limit (LEL). Experience has shown that increased pressure has little effect on LEL for a given flammable gas and oxygen concentration. A safety factor of 10 is recommended. Flammable liquids should be confined to nonbreakable, nonspill containers.

*Sample Determination.* An example of limiting quantity of flammable agent substance:

Isopropyl alcohol (2-propanol)

LEL = 2%/vol. (irrespective of chamber pressure)

Vapor density = 2.1 relative to air

Liquid density = 786 g/L (49.1 lb/ft<sup>3</sup>)

Air density = 0.075 lb/ft<sup>3</sup> (1.2 kg/m<sup>3</sup>) at STP

The limiting case occurs at the lowest ambient pressure, that is, 1 atmosphere:

$$\begin{aligned} \text{Alcohol vapor density at LEL} &= 0.02 \times 2.1 \times 0.075 \\ &= 0.00315 \text{ lb/ft}^3 \text{ (0.05 kg/m}^3\text{)} \\ &= 1.43 \text{ g/ft}^3 \text{ (0.05 kg/m}^3\text{)} \end{aligned}$$

For a relatively small 500 ft<sup>3</sup> (14.2 m<sup>3</sup>) chamber, this implies: 1.43 × 500 = 715 g (1.58 lb) alcohol vapor at LEL

Using a safety factor of 10 to account for uneven vapor concentrations gives 71.5 g = 91 mL (3 oz) alcohol.

One could conclude that even 90 mL (3 oz) of alcohol is more than would be needed for almost any medical procedure. The preceding calculation also does not account for the mitigating effect of ventilation.

Many “inert” halogenated compounds have been found to act explosively in the presence of metals, even under normal atmospheric conditions, despite the fact that the halogen compound itself does not ignite in oxygen or, in the case of solids such as polytetrafluoroethylene, is self-extinguishing. Apparently these materials are strong oxidizers, whether gases, liquids (solvents, greases), or solids (electrical insulation, fabric, or coatings). Some halogenated hydrocarbons that will not burn in the presence of low pressure oxygen will ignite and continue to burn in high pressure oxygen. Customarily, Class A chambers maintain internal oxygen concentration that does not exceed 23.5 percent.

Parts of Chapter 14 deal with the elements required to be incorporated into the structure of the chamber to reduce the possibility of electrostatic spark discharges, which are a possible cause of ignition in hyperbaric atmospheres. The elimination of static charges is dependent on the vigilance of administrative activities in materials, purchase, maintenance supervision, and periodic inspection and testing. It cannot be emphasized too strongly that an incomplete chain of precautions generally will increase the electrostatic hazard. For example, conductive flooring can contribute to the hazard unless all personnel wear conductive shoes, all objects in the room are electrically continuous with the floor, and humidity is maintained.

The limitations in 14.3.1.5.2.2 on the use in the chamber of alcohol and other agents that emit flammable vapors should be strictly observed, and such restrictions should be prominently posted.

**A.14.3.1.5.3** The number of occupants of the chamber should be kept to the minimum number necessary to carry out the procedure.

**A.14.3.1.5.4** It is recommended that all chamber personnel should wear garments of the overall or jumpsuit type that com-

pletely cover all skin areas to the extent possible and that are as tight-fitting as possible. It can be impractical to clothe some patients (depending upon their disease or the site of any surgery) in such garments. Hospital gowns can be employed in such a case.

**A.14.3.1.5.4.3** The textiles definitions and risk assessment process for hyperbaric wound dressings are as follows:

*Combustion.* A chemical process of oxidation that occurs at a rate fast enough to produce heat in the form of either a glow or a flame.

*Flammable.* Refers to a combustible (solid, liquid, or gas) that is capable of easily being ignited and rapidly consumed by fire.

*Flash Point.* The minimum temperature of a liquid or solid at which it gives off vapor sufficient to form an ignitable mixture with oxygen under specified environmental conditions.

*Ignition Temperature.* The minimum temperature required to initiate or cause self-sustaining combustion under specified environmental conditions.

*Lower Explosive Limit (LEL) or Lower Flammable Limit (LFL).* The minimum concentration of fuel vapor (percent by volume) over which combustion will occur on contact with an ignition source.

*General Risk Assessment Information.* This risk assessment process was designed to evaluate wound dressing products for use in a hyperbaric chamber. However, the same decision process can be applied to the evaluation of textiles for hyperbaric use. Wound dressings are commonly used inside hyperbaric chambers. They play an important role in infection control and patient outcome. Important safety concerns include production of heat, production of static electricity, production of flammable vapor, ignition temperature, and total fuel load. Many wound dressings employ fabrics and other materials that are gas-permeable. It is a common misconception that a gauze bandage will isolate an undesirable product from the chamber environment. Gauze is gas-permeable and will allow oxygen from the chamber to interact with the product and vapors from the product to interact with the chamber environment. Also, gas-permeable materials exposed to hyperbaric oxygen will hold additional oxygen for some period of time after the exposure. These materials should be kept away from open flames for at least 20 minutes after the hyperbaric treatment.

*Risk Assessment Process (see Figure A.14.3.1.5.4.3).*

- (1) Is there a more suitable alternative to this dressing? The issue of need must first be addressed. There might be a substitute dressing that has already been deemed acceptable for the hyperbaric environment. The wound dressing orders can be changed to the more desirable substitute (if there is no negative impact on patient outcome). It might be viable to remove the dressing before the hyperbaric treatment, leave it off during the treatment, and replace it after the treatment. Before making this decision, it is important to remember that some dressings should not be disturbed (e.g., in the case of a new skin graft); some dressings are designed to stay in place for several days; some dressings are very expensive; and it can be detrimental for the wound to remain undressed during the treatment. If there is a suitable alternative to using this dressing, the rest of the decision process can be eliminated.



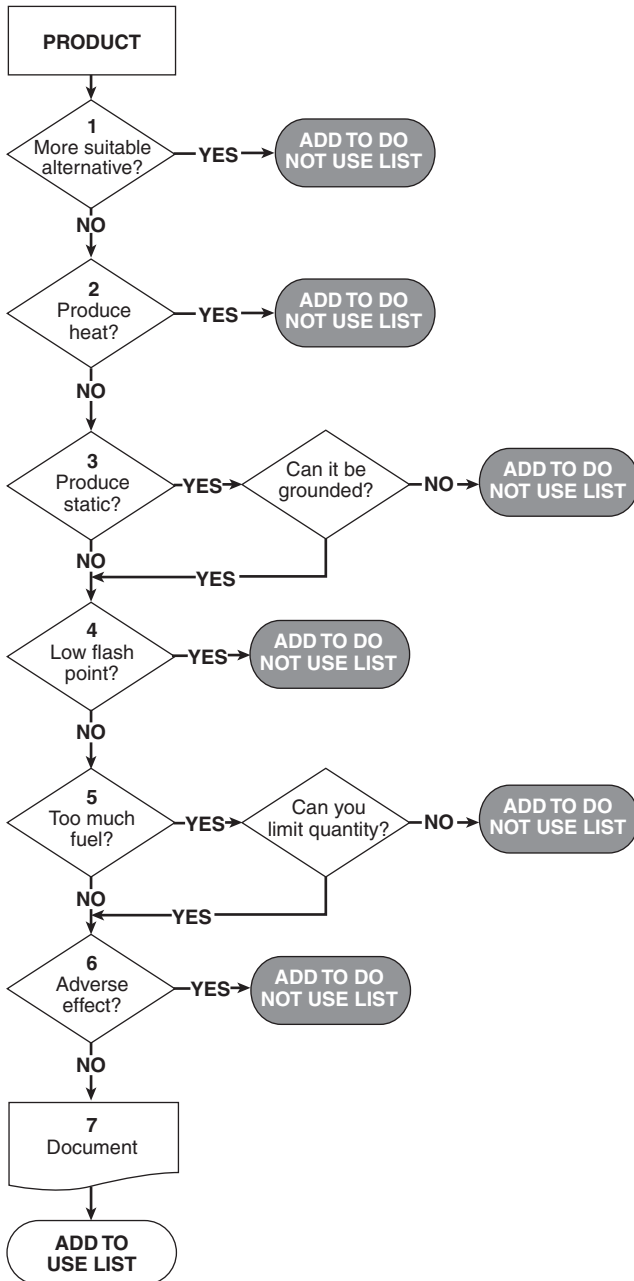


FIGURE A.14.3.1.5.4.3 Risk Assessment Process.

(2) Does this dressing produce heat in the chamber? Dressings are made from a large variety of materials. The concern is that materials in a dressing can rapidly oxidize and produce heat (exothermic reaction) when exposed to additional oxygen. For example, air-activated heat patches (commonly used for pain relief) have been tested in hyperbaric environments. The average operating temperature increased from 48.1°C (119°F) in normobaric air to 121.8°C (251°F) in hyperbaric oxygen. In this circumstance, the patient's skin would be burned, and the heat could ignite combustible material in the chamber. Information on oxygen compatibility can be found in a product material safety data sheet (MSDS).

- (3) Does this dressing produce too much static electricity? All common textiles will contribute to static production. Wool and synthetic materials generally contribute more to static production than cotton. Although static charge is constantly accumulating, it will dissipate into the environment when humidity is present. At less than 30 percent relative humidity, static charge can accumulate faster than it can dissipate. At greater than 60 percent relative humidity, static charge is all but completely eliminated. Use of conductive surfaces and electrical grounding will allow static charge to dissipate. Paragraph 14.2.7.4.1 requires all hyperbaric chambers to be grounded. Paragraph 14.2.9.1 requires any furniture installed inside a chamber to be grounded. Paragraph 14.3.1.5.3.2 requires all occupants of the chamber to be grounded when the oxygen percentage in the chamber is above 23.5 percent. The continuity of electrical grounds should be verified periodically.
- (4) Does this dressing have a low ignition temperature/flash point? In all hyperbaric environments, the partial pressure of oxygen is higher than at normal atmospheric conditions. Increasing the partial pressure of oxygen can change the classification of a material from non-flammable to flammable. Many materials are flammable in a 100 percent oxygen environment. Any material used in a hyperbaric chamber should have an ignition temperature higher than it can be exposed to. Paragraph 14.2.7.3.12 limits electrical equipment inside a Class A (multi-place) chamber to a maximum operating surface temperature of 85°C (185°F). Paragraph 14.2.7.6.3 limits electrical circuits inside a Class B (monoplace) chamber to a maximum operating temperature of 50°C (122°F). As the oxygen percentage increases, it takes less energy to ignite materials. This leads to more conservative decisions in a 100 percent oxygen environment. A greater margin of safety is achieved when there is a greater difference between the temperature limit of the equipment inside a Class A and B chamber and the ignition temperature of material in question. A material will release vapor into the chamber environment as it approaches its flash point temperature. Once a sufficient quantity of vapor is present in the chamber (LEL), it takes very little energy for ignition to occur. Paragraph 14.3.1.5.2.2 sets limits on flammable agents inside Class A (multi-place) chambers. Paragraph 14.3.1.5.2.3 specifically prohibits flammable liquids, gases, and vapors inside Class B (monoplace) chambers. Information on ignition temperature and flash point in air can be found in a product MSDS.
- (5) Is the total fuel load too high? If a fire does occur, the energy produced is a function of the partial pressure of oxygen and the total fuel load. In a hyperbaric environment, the partial pressure of oxygen is higher and contributes to greater energy production. Any dressing product placed inside of a hyperbaric chamber is a combustible material and, therefore, adds to the fuel load. Therefore, total fuel load inside the chamber should be minimized to only what is necessary.
- (6) Is there an adverse effect when this product is used inside the hyperbaric chamber? It has been reported that the antibacterial agent mafenide acetate (Sulfamylon®), in combination with hyperbaric oxygen, has a poorer clinical result than either one by itself. There can be other drug interactions with hyperbaric oxygen that are undesirable. The mechanical effects of pressure change can cause a dressing material to rupture. If the material is capable of venting/equalizing during pressure change, this should not occur.



- (7) The hyperbaric facility should maintain a “use list” and a “do not use list” of items that have been evaluated for hyperbaric use. In addition to this list, it is important to keep documentation on file explaining the risk assessment for each item. This will prevent future duplication of effort. It also serves as evidence that due diligence was used.

*References:*

- (1) NFPA 53, *Recommended Practice on Materials, Equipment, and Systems Used in Oxygen-Enriched Atmospheres*. (2004). Quincy (MA): National Fire Protection Association.
- (2) NASA BMS Document GRC-M8300.001. (2005). Ch. 5, Para. 5.6.3.
- (3) Raleigh, G., et al. (2005). *Air-Activated Chemical Warming Devices: Effects of Oxygen and Pressure*. Undersea Hyper Med, 32(6).
- (4) Workman, W.T. (1999). *Hyperbaric Facility Safety: A Practical Guide* (p. 531). Flagstaff (AZ): Best Publishing.
- (5) Kindwall, E.P., & Whelan, H.T. (2004). *Hyperbaric Medicine Practice* (p. 86). Flagstaff (AZ): Best Publishing.
- (6) Burman, F. (2006). *Risk Assessment Guide for the Installation and Operation of Clinical Hyperbaric Facilities*, 4th edition. San Antonio (TX): International ATMO.

**A.14.3.2.1.6** The use of paper should be kept to an absolute minimum in hyperbaric chambers.

**A.14.3.2.2** Users should be aware that many items, if ignited in pressurized oxygen-enriched atmospheres, are not self-extinguishing. Iron alloys, aluminum, and stainless steel are, to various degrees, in this category, as well as human skin, muscle, and fat, and plastic tubing such as polyvinyl chloride (Tygon®). Testing for oxygen compatibility is very complicated. Very little data exist, and many standards still have to be determined. Suppliers do not normally have facilities for testing their products in controlled atmospheres, especially high pressure oxygen. Both static conditions and impact conditions are applicable. Self-ignition temperatures normally are unknown in special atmospheres.

**A.14.3.2.5** See A.14.3.2.2.

**A.14.3.2.6** Radiation equipment, whether infrared or roentgen ray, can make hyperbaric chambers even more hazardous.

**A.14.3.3.4** Quantities of oxygen stored in the chamber should be kept to a minimum.

**A.14.3.6** The elimination of static charges is dependent on the vigilance of administrative supervision of materials purchased, maintenance, and periodic inspection and testing.

**A.14.3.6.2.1.2** Ferrous metals can cause such sparking, as can magnesium or magnesium alloys, if contact is made with rusted steel.

**A.14.3.6.2.3** Materials containing rubber deteriorate rapidly in oxygen-enriched atmospheres.

**A.14.3.6.4** It is absolutely essential that all areas of, and components associated with, the hyperbaric chamber be kept meticulously free of grease, lint, dirt, and dust.

**A.15.3.2** NFPA 58, *Liquefied Petroleum Gas Code*, permits portable butane-fueled appliances in restaurants and in attended commercial food catering operations where fueled by not in excess of two 0.28 kg (10 oz) LP-Gas capacity, nonrefillable butane containers having a water capacity not in excess of 0.4 kg (1.08 lb) per container. Containers are

required to be directly connected to the appliance, and manifolding of containers is not permitted. Storage of cylinders is also limited to 24 containers, with an additional 24 permitted where protected by a 2-hour fire resistance-rated barrier. [**101**: A.8.7.3.2]

**A.15.5.2.1** This section is different from 9.2.1 of NFPA 101, *Life Safety Code*, because NFPA 90B, *Standard for the Installation of Warm Air Heating and Air-Conditioning Systems*, referenced in NFPA 101, is not applicable to health care facilities.

**A.15.5.3.3** Continued operation of solid-state elevator equipment is contingent on maintaining the ambient temperature in the range specified by the elevator manufacturer. If the machine room ventilation/air-conditioning is connected to the general building system, and that system is shut down during a fire, the fire department might lose the use of elevators due to excessive heat in the elevator machine room. [**101**: A.9.4.5]

**A.15.7.1** The provisions of Section 15.7 cover the basic functions of a complete fire alarm system, including fire detection, alarm, and communications. These systems are primarily intended to provide the indication and warning of abnormal conditions, the summoning of appropriate aid, and the control of occupancy facilities to enhance protection of life.

Some of the provisions of Section 15.7 originated with NFPA 72, *National Fire Alarm and Signaling Code*. For purposes of this Code, some provisions of Section 15.7 are more stringent than those of NFPA 72, which should be consulted for additional details. [**101**: A.9.6.1]

**A.15.7.2.4** It is not the intent of 15.7.2.4 to require manual fire alarm boxes to be attached to movable partitions or to equipment, nor is it the intent to require the installation of permanent structures for mounting purposes only. [**101**: A.9.6.2.5]

**A.15.7.4.2.1** Elevator lobbies have been considered areas subject to unwanted alarms due to factors such as low ceilings and smoking. In the past several years, new features have become available to reduce this problem. These features are, however, not necessarily included in any specific installation. [**101**: A.9.6.3.2.1]

**A.15.7.4.2.2** The concept addressed is that detectors used for releasing service, such as door or damper closing and fan shut-down, are not required to sound the building alarm. [**101**: A.9.6.3.2.2]

**A.15.7.4.3.1** It is not the intent of this paragraph to require fire alarm system zones to coincide with smoke compartment boundaries, provided that the facility fire plan addresses the differences between fire alarm system zones and building smoke compartments.

**A.15.7.4.3.2** In the private operating mode, audible and visible signaling is required only to those persons directly concerned with the implementation and direction of emergency action. Provided that those persons receive alarm notification, audible and visible signaling is not required to patients or other building occupants who are not responsible for the implementation and direction of emergency action.

**A.15.8.1.2** It is not the intent of this paragraph to require sprinkler system zones to coincide with smoke compartment boundaries, provided that the facility fire plan addresses the differences between sprinkler systems zones and building smoke compartments.

**A.15.8.1.3** Although this exception is currently not recognized by NFPA 13, *Standard for the Installation of Sprinkler Systems*, a proposal has been submitted for consideration by the NFPA 13 Technical Committee on Sprinkler System Installation Criteria. This exception is limited to hospitals as nursing homes and many limited care facilities can have more combustibles within the closets. The limited amount of clothing found in the small clothes closets in hospital patient rooms is typically far less than the amount of combustibles in casework cabinets that do not require sprinkler protection such as nurse servers. In many hospitals, especially new hospitals, it is difficult to make a distinction between clothes closets and cabinet work. This exception is far more restrictive than similar exceptions for hotels and apartment buildings. NFPA 13 already permits the omission of sprinklers in wardrobes [see 8.1.1(7) of NFPA 13]. It is not the intent of this paragraph to affect the wardrobe provisions of NFPA 13. It is the intent that the sprinkler protection in the room covers the closet as if there was no door on the closet (see 8.5.3.2.3 of NFPA 13). [101: A.18.3.5.8]

**A.15.9.1** The selection of portable fire extinguishers for health care facilities is a vital step in preparing the facility to effectively deal with a fire in its incipient stage. There are special extinguisher requirements such as nonferrous fire extinguisher components of fire extinguishers in an MRI room or area, and Class K extinguishers in kitchens. There is a need to consider extinguishing agents for various areas of a facility that are nontoxic, noncorrosive, and/or nonconductive. Chapters 5 and 6 and their Annex A notes of NFPA 10, *Standard for Portable Fire Extinguishers*, need very careful review. Annex C, “Fire Extinguisher Selection” and Annex D, “Operation and Use” of NFPA 10 provide additional valuable guidance.

**A.15.9.2.2** Hose and hose outlets can be required by a building code or by the authority having jurisdiction.

**A.15.10** Compact storage is characterized by shelving units that are manually or electrically moved on fixed tracks to provide access aisles. Such systems are also known as mobile shelving, track files, compaction files, or movable files.

A floor loading calculation should be performed.

**A.15.11.3** NFPA 13, *Standard for the Installation of Sprinkler Systems*, contains protection criteria for limited configurations of compact mobile storage units and materials stored. Storage arrangements not specifically addressed in NFPA 13 are outside the scope of the standard (i.e., protection for plastic commodities in compact mobile storage units does not simply follow high piled storage protection criteria for shelves or racks). Where compact mobile storage configurations outside the scope of NFPA 13 are to be utilized, they must be addressed on a case-by-case basis, with consideration given to the fact that no known sprinkler protection criteria is currently available. The storage of paper administrative and medical records with limited plastic labels or folders is typically a Class III commodity with less than 5 percent plastics. The storage of most office supplies, engineering parts, food products, garments, and other general supplies is typically a Class IV commodity with 5 percent to

25 percent plastics. The storage of X-rays, medicines, and plastic-based medical supplies is typically a Group A plastics commodity with greater than 25 percent plastics.

**A.15.13** The following definitions were adapted from the ACS publication 04GR-0001, *Guidelines for Optimal Ambulatory Surgical Care and Office-Based Surgery*, which was developed by the Board of Governors Committee on Ambulatory Surgical Care. Class A, Class B, and Class C operating rooms are classified as follows:

**Class A** — Provides for minor surgical procedures performed under topical and local infiltration blocks with or without oral or intramuscular preoperative sedation. (Excluded are procedures that make use of spinal, epidural axillary, and stellate ganglion blocks; regional blocks (e.g., interscalene) and supraclavicular, infraclavicular, and intravenous regional anesthesia.) These procedures are also appropriately performed in Class B and C facilities.

**Class B** — Provides for minor or major surgical procedures performed in conjunction with oral, parenteral, or intravenous sedation or under analgesic or dissociative drugs. These procedures are also appropriately performed in Class C facilities.

**Class C** — Provides for major surgical procedures that require general or regional block anesthesia and support of vital bodily functions.

**A.15.13.3.2** Some tinctures and solutions of disinfecting agents provide significant clinical benefits in reducing the risk of surgical infections. However, they can be flammable and can be used improperly during surgical procedures. Tipping containers, accidental spillage, and the pouring of excessive amounts of such flammable agents on patients expose them to injury in the event of accidental ignition of the flammable solvent. To control this risk, flammable germicides or antiseptics that are used when electrosurgery, cautery, or a laser is contemplated should be packaged to ensure controlled delivery to the patient (e.g., unit dose applicator, swab) in small volumes appropriate for single application.

## Annex B Additional Explanatory Notes

*This annex is not a part of the requirements of this NFPA document but is included for informational purposes only.*

**B.1 Reserved.**

**B.2 Reserved.**

**B.3 Reserved.**

**B.4 Reserved.**

**B.5 Additional Information on Chapter 5.** Numbers in brackets refer to paragraphs in Chapter 5.

**B.5.1 General.** This section sets out a minimum recommended guide for testing. Testing requirements are listed in 5.1.12 and summarized in Table B.5.1. Tests specified in 5.1.12 should be carried out by an experienced person or persons designated by the administration of the health care facility. Such a person(s) should certify the results of tests to the administration. The designated person(s) should be experienced in medical gas testing and verification of piping systems with cross-connection testing. A member of the health care facility should be present to verify the testing.

**Table B.5.1 Performance Criteria and Testing — Level 1 (Gases, Medical–Surgical Vacuum, and WAGD)**

Responsibility	Test Reference	Test (as Applicable)	Purpose of Test
Installer	5.1.12.2.1	General	
Installer	5.1.12.2.2	Initial blow down	Distribution piping is blown down to remove particulates
Installer	5.1.12.2.3	Initial pressure test	Distribution piping is free from pressure loss
Installer	5.1.12.2.4	Cross-connection test	Distribution piping is free from cross-connections
Installer	5.1.12.2.5	Piping purge test	Distribution piping is purged to remove particulates
Installer	5.1.12.2.6	Standing pressure test for positive pressure medical gas piping	Distribution piping is free from excessive pressure loss
Installer	5.1.12.2.7	Standing vacuum test for vacuum system	Distribution piping is free from excessive vacuum loss
System verification	5.1.12.3.1	General	
System verification	5.1.12.3.2	Standing pressure test	Distribution piping is free from leaks
System verification	5.1.12.3.3	Cross-connection test	Distribution piping is free from cross-connections
	5.1.12.3.3.1	Individual pressurization	
	5.1.12.3.3.2	Pressure differential	
System verification	5.1.12.3.4	Valve test	Shutoff valves are functioning and labeled properly
System verification	5.1.12.3.5	Alarm test	Alarms are functioning and labeled properly
	5.1.12.3.5.1	General	
	5.1.12.3.5.2	Master alarm	
	5.1.12.3.5.3	Area alarm	
System verification	5.1.12.3.6	Piping purge test	Distribution piping is purged to remove particulates
System verification	5.1.12.3.7	Piping particulate test	Distribution piping is free from particulates
System verification	5.1.12.3.7.6	Piping purity test	Distribution piping is free from excessive water vapor, total hydrocarbons, and halogenated hydrocarbons
System verification	5.1.12.3.9	Final tie-in test	The new and existing distribution system is free from leaks at the point of connection, and no additional contamination was added to the existing system
System verification	5.1.12.3.10	Operational pressure test	Distribution piping is free from excessive pressure/vacuum loss
System verification	5.1.12.3.11	Medical gas concentration test	Proper concentration of system gas is present at each outlet
System verification	5.1.12.3.12	Medical air purity test (compressor system)	Proper quality of medical air is present
System verification	5.1.12.3.13	Labeling	Distribution piping, outlets/inlets, shutoff valves, alarms, and source equipment are labeled correctly
System verification	5.1.12.3.14	Source equipment verification	Source equipment properly functions
	5.1.12.3.14.1	General	
	5.1.12.3.14.2	Gas supply sources	
	5.1.12.3.14.3	Medical air compressor systems	
	5.1.12.3.14.5	Medical–surgical vacuum systems	

### **B.5.2 Retesting and Maintenance of Nonflammable Medical Piped Gas Systems (Level 1 Systems).**

**B.5.2.1 [5.1.3.5.10]** These systems should be checked daily to ensure that proper pressure is maintained and that the changeover signal has not malfunctioned. Periodic retesting of the routine changeover signal is not necessary, as it will normally be activated on a regular basis.

**B.5.2.2 [5.1.3.5.12]** These systems should be checked daily to ensure that proper pressure is maintained and that the changeover signal has not malfunctioned. Periodic retesting of the routine changeover signal is not required. Annual retesting of the operation of the reserve and activation of the reserve-in-use signal should be performed.

**B.5.2.3 [5.1.3.5.12]** If the system has an actuating switch and signal to monitor the contents of the reserve, it should be retested annually.

**B.5.2.4 [5.1.3.5.13]** Maintenance and periodic testing of the bulk system is the responsibility of the owner or the organization responsible for the operation and maintenance of that system.

The staff of the facility should check the supply system daily to ensure that medical gas is ordered when the content's gauge drops to the reorder level designated by the supplier. Piping system pressure gauges and other gauges designated by the supplier should be checked regularly, and gradual variation, either increases or decreases, from the normal range should be reported to the supplier. These variations might indicate the need for corrective action.

Periodic testing of the master signal panel system, other than the routine changeover signal, should be performed. Assistance should be requested from the supplier or detailed instruction if readjustment of bulk supply controls is necessary to complete these tests.

**B.5.2.5 [5.1.8.2.3]** The main line pressure gauge should be checked daily to ensure the continued presence of the desired pressure. Variation, either increases or decreases, should be investigated and corrected.

**B.5.2.6 [5.1.3.6.3.14]** Quarterly rechecking of the location of the air intake should be made to ensure that it continues to be a satisfactory source for medical compressed air.

**B.5.2.7 [5.1.3.6.3.14]** Proper functioning of the pressure gauge and high water level sensor should be checked at least annually. The receiver drain should be checked daily to determine if an excessive quantity of condensed water has accumulated in the receiver.

**B.5.2.8 [5.1.3.6]** An important item required for operation of any medical compressed air supply system is a comprehensive preventive maintenance program. Worn parts on reciprocating compressors can cause high discharge temperatures, resulting in an increase of contaminants in the discharge gas. Adsorber beds, if not changed at specified time intervals, can become saturated and lose their effectiveness. It is important that all components of the system be maintained in accordance with the manufacturers' recommendations. It is important that any instrumentation, including analytical equipment, be calibrated routinely and maintained in operating order. Proper functioning of the dew point sensor should be checked at least annually.

**B.5.2.9 [5.1.9]** When test buttons are provided with signal panels, activation of the audible and visual signals should be performed on a regular basis (monthly).

**B.5.2.10 [5.1.9.2.4] Changeover Warning Signals.** As these are routine signals that are activated and deactivated at frequent intervals, there is no need for retesting unless they fail. If the reserve-in-use signal is activated because both units of the operating supply are depleted without the prior activation of the changeover signal, it should be repaired and retested.

**B.5.2.11 [5.1.9.2.4] Reserve-In-Use Warning Signal.** All components of this warning signal system should be retested annually. Audible and visual signals should be tested periodically during the year (monthly).

**B.5.2.12 [5.1.9.2.4] Reserve Supply Low (Down to an Average One-Day Supply) High Pressure Cylinder or Liquid Reserve.** All components of these signal warning systems should be retested annually. If test buttons are provided, audible and visual signals should be periodically tested throughout the year (monthly).

**B.5.2.13 [5.1.9.2.4]** The medical compressed air system alarms in 5.1.3.6.3.13 should be checked at least annually.

**B.5.2.14 [5.1.8.2.2(1)]** This pressure gauge should be checked on a daily basis to ensure proper piping system pressure. A change, increase or decrease, if noted, could be evidence that maintenance is required on the line pressure regulator and could thus avoid a problem.

**B.5.2.15 [5.1.9]** Annual retesting of all components of warning systems, if it can be done without changing piping system line pressure, should be performed.

**B.5.2.16 [5.1.9]** If test buttons are provided, the retesting of audible and visual alarm indicators should be performed monthly.

**B.5.2.17 [5.1.4]** Shutoff valves should be periodically checked for external leakage by means of a test solution or other equally effective means of leak detection that is safe for use with oxygen.

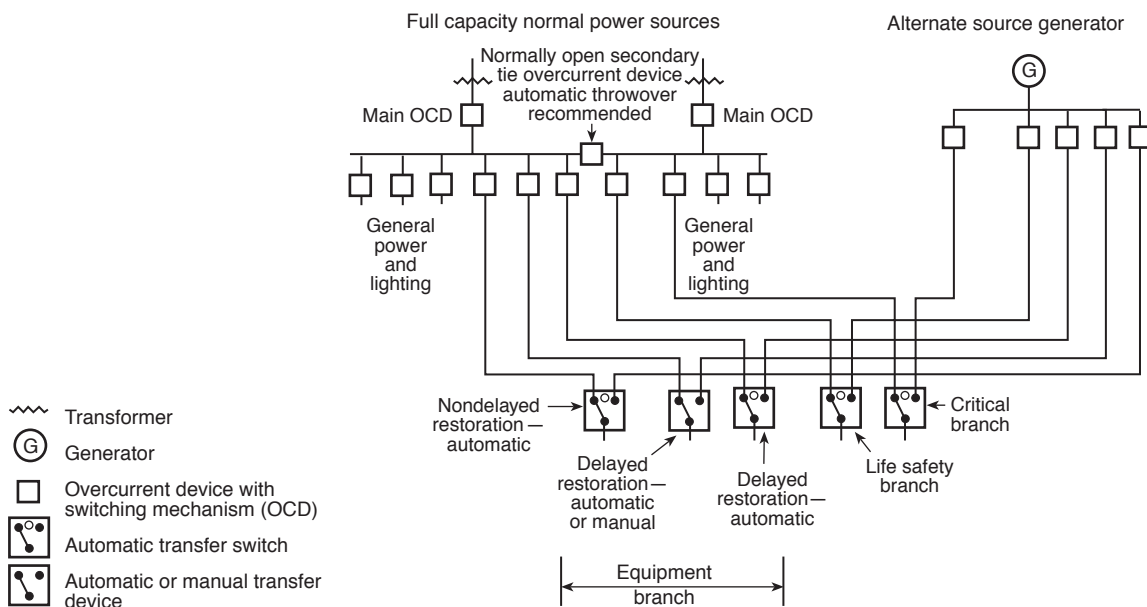
**B.5.2.18 [5.1.5]** Station outlets should be periodically checked for leakage and flow. Manufacturer instructions should be followed in making this examination.

**B.5.3 Oxygen Service-Related Documents.** The following publications can be used for technical reference:

- (1) ASTM G 63, *Standard Guide for Evaluating Nonmetallic Materials for Oxygen Service*
- (2) ASTM G 88, *Standard Guide for Designing Systems for Oxygen Service*
- (3) ASTM G 93, *Practice for Cleaning Methods and Cleanliness Levels for Material and Equipment Used in Oxygen-Enriched Environments*
- (4) ASTM G 94, *Standard Guide for Evaluating Metals for Oxygen Service*

### **B.6 Additional Information on Chapter 6.**

**B.6.1 Typical Hospital Wiring Arrangement.** See Figure B.6.1. Separate transfer switches for each branch, as shown, are required only if dictated by load considerations. Smaller facilities can be served by a single transfer switch.



**FIGURE B.6.1 Typical Hospital Wiring Arrangement.**

**B.6.2 Maintenance Guide for an Essential Electrical System.**

This generalized maintenance guide is provided to assist administrative, supervisory, and operating personnel in establishing and evaluating maintenance programs for emergency electric generating systems. See Figure B.6.2.

**B.6.3 Suggested Format for Listing Functions to Be Served by the Essential Electrical System in a Hospital.**

It might be advantageous in listing the specific functions for a given construction project or building review to list them, at the outset, by geographical location within the project in order to ensure comprehensive coverage. Every room or space should be reviewed for possible inclusion of the following:

- (1) Lighting (partial or all)
- (2) Receptacles (some or all)
- (3) Permanently wired electrical apparatus

The format suggested herein is offered as a convenient tool, not only for identifying all functions to be served and their respective time intervals for being re-energized by the alternate electric source, but also for documenting other functions that were considered, discussed, and excluded as nonessential. The last column in Figure B.6.3 is considered worthy of attention (see Figure B.6.3). It might be that the hospital engineer or the reviewing authority will wish to keep on file a final copy of the list, which would be the basis for the electrical engineer's detailed engineering design.

Although this suggested format is intended for use by a hospital, it might, with suitable changes, be useful for other health care facilities.

**B.7 Reserved.**

**B.8 Reserved.**

**B.9 Reserved.**

**B.10 Reserved.**

**B.11 Additional Information on Chapter 11.**

**B.11.1 Medical Safeguards — Respiratory Therapy.**

**B.11.1.1 General.**

**B.11.1.1.1** Personnel setting up, operating, and maintaining respiratory therapy equipment, including suction apparatus, should familiarize themselves with the problems of the use of each individual unit.

**B.11.1.1.2** Personnel must be aware of the exact location of equipment in storage to facilitate emergency use.

**B.11.1.1.3** Suction tubing employed in a hazardous location is to be electrically conductive.

**B.11.2 Glossary of Respiratory Therapy Terminology.**

**B.11.2.1 Arrhythmia.** Irregularity of heartbeats.

**B.11.2.2 Asphyxia.** Suffocation from lack of oxygen and an accumulation of carbon dioxide.

**B.11.2.3 Aspiration.** Removal of accumulated mucus by suction.

**B.11.2.4 Bronchi.** The two primary divisions of the trachea.

**B.11.2.5 CPAP.** Continuous positive airway pressure.

**B.11.2.6 CPR.** Cardiopulmonary resuscitation.

**B.11.2.7 Croup Tent.** Equipment utilized to provide environmental control inside a canopy in relation to oxygen concentration, temperature, humidity, and filtered gas.

**B.11.2.8 Cyanosis.** A bluish discoloration of skin and mucus membranes due to excessive concentration of reduced hemoglobin in the blood.

**B.11.2.9 Defibrillate.** Use of electrical shock to synchronize heart activity.

## MAINTENANCE GUIDE

### Monthly

- a. Testing of generator sets and transfer switches under load and operating temperature conditions at least every 30 days. A 30-minute exercise period is an absolute minimum, or the engine manufacturer's recommendations should be followed.
- b. Permanently record all available instrument readings during the monthly test.
- c. During the monthly test, check the following system or systems applicable to your installation:

**Natural Gas or Liquid Petroleum Gas System:**

- Operation of solenoids and regulators
- Condition of all hoses and pipes
- Fuel quantity

**Gasoline Fuel System:**

- Main tank fuel level
- Operation of system

**Diesel Fuel System:**

- Main tank fuel level
- Day tank fuel level
- Operation of fuel supply pump and controls

**Turbine Prime Movers:**

- Follow manufacturer's recommended maintenance procedure

**Engine Cooling System:**

- Coolant level
- Rust inhibitor in coolant
- Antifreeze in coolant (if applicable)
- Adequate cooling water to heat exchangers
- Adequate fresh air to engine and radiators
- Condition of fan and alternator belts
- Squeeze and check condition of hose and connections
- Functioning of coolant heater (if installed)

**Engine Lubricating System:**

- Lubricating oil level
- Crankcase breather not restricted
- Appearance of lubricating oil
- Correct lubricating oil available to replenish or change
- Operation of lubricating oil heater (if installed)
- Oil pressure correct

**Engine Electrical Starting System:**

- Battery terminals clean and tight
- Add distilled water to maintain proper electrolyte level
- Battery charging rate
- Battery trickle charging circuit operating properly
- Spare batteries charged (if provided)

**Engine Compressed Air Starting System:**

- Air compressor operating properly
- Air compressor lubricating oil level
- Spare compressed air tanks full
- Main compressed air tanks full
- Drain water from compressed air tanks

**Engine Exhaust System:**

- Condensate trap drained
- No exhaust leaks
- Exhaust not restricted
- All connections tight

**Transfer Switch:**

- Inside clean and free of foreign matter
- No unusual sounds
- Terminals and connectors normal color
- Condition of all wiring insulation
- All covers tight
- Doors securely closed

**General:**

- Any unusual condition of vibration, deterioration, leakage, or high surface temperatures or noise
- Maintenance manuals, service log, basic service tools, jumpers, and supplies readily available
- Check and record the time intervals of the various increments of the automatic start-up and shutdown sequences
- Overall cleanliness of room
- No unnecessary items in room

d. After the monthly test: Take prompt action to correct all improper conditions indicated during test. Check that the standby system is set for automatic start and load transfer.

### Quarterly

a. On generator sets:

**Engine Electrical Starting System:**

- Check battery electrolyte specific gravity
- Check battery cap vents

**Engine Lubricating System:**

- Check lubricating oil (or have analyzed if part of an engineered lube oil program)

b. Fuel System:

- Drain water from fuel filters (if applicable)
- Drain water from day tank (if applicable)
- Check fuel gauges and drain water from main fuel tanks
- Inspect all main fuel tank vents

**FIGURE B.6.2 Maintenance Guide for Essential Electrical System.**

**MAINTENANCE GUIDE (Continued)**

**Semiannually**

On generator sets:

Engine Lubricating System:

- Change oil filter (if sufficient hours)
- Clean crankcase breather

Fuel System:

- General inspection of all components
- Change fuel filter
- Change or clean air filter

Governor:

- Check all linkages and ball joints
- Check oil level (if applicable)
- Observe for unusual oil leakage

Generator:

- Check brush length and pressure
- Check appearance of slip rings and clean if necessary
- Blow out with clean, dry compressed air

Engine Safety Controls:

- Check operation of all engine-operating alarms and safety shutdown devices (generator not under load during this check)

**Annually**

a. On generator sets:

Fuel System:

- Diesel:
- Analyze fuel for condition (replace if required)

Gasoline:

- Replace fuel

Natural Gas or Liquefied Petroleum Gas:

- Examine all supply tanks, fittings, and lines

Lubricating Systems:

- Change oil
- Change oil filter
- Replace carburetor air filter

Cooling System:

- Check condition and rod-out heat exchangers if necessary
- Change coolant on closed systems
- Clean exterior of all radiators
- Check all engine water pumps and circulating pumps
- Examine all duct work for looseness
- Clean and check motor-operated louvers

Exhaust System:

- Check condition of mufflers, exhaust lines, supports, and connections

Ignition System:

- Spark ignition engines
- Replace points and plugs
- Check ignition timing
- Check condition of all ignition leads

Generator:

- Clean generator windings
- Check generator bearings
- Measure and record resistance readings of generator windings using insulation tester (megger)

Engine Control:

- General cleaning
- Check appearance of all components
- Check meters

b. Transfer Switch:

- Inspect transfer switch and make repairs or replacements if indicated

c. On main switchgear and generator switchgear:

- Operate every circuit breaker manually
- Visually check bus bars, bracing, and feeder connections for cleanliness and signs of overheating

**Every 3 Years**

a. System Controls:

- Reevaluate the settings of the voltage-sensing and time delay relays.

b. Main Switchgear and Generator Switchgear:

- Determine whether changes to the electrical supply system have been made that require a revision of the main circuit breaker, fuse, or current-limiting bus duct coordination.
- Calibrate and load test main circuit breakers. Spot-check bus bar bolts and supports for tightness. Obtain and record insulation tester readings on bus bars and circuit breakers. Obtain and record insulation tester readings on internal distribution feeders.

**Periodically**

a. Prime Mover Overhaul:

- Each prime mover should have a periodic overhaul in compliance with the manufacturer's recommendation or as conditions warrant.

b. Connected Load:

- Update the record of demand and connected load and check for potential overload.

FIGURE B.6.2 *Continued*





**B.11.3.4.1.2** Before attempting to fight the fire with water or a water-based extinguishing agent, electrical apparatus should be disconnected from the supply outlet, or the supply circuit should be de-energized at the circuit panel.

**B.11.3.4.1.3** If de-energization at the circuit panel cannot be accomplished, water should not be employed. (See B.11.3.4.2.)

**B.11.3.4.2** Fires involving or adjacent to electrical equipment with live circuits can be fought with extinguishers suitable for Class C fires in accordance with NFPA 10, *Standard for Portable Fire Extinguishers*.

Note that chemical extinguishers are not effective against fires in oxygen-enriched atmospheres unless the source of oxygen is shut off. See B.11.3.3 for closing off the oxygen supply.

**B.11.3.5 Protection of Patients and Personnel.**

**B.11.3.5.1** Because of the intense heat generated, serious and even fatal burns of the skin or of the lungs from inhaling heated gases are possible sequelae to a fire in an oxygen-enriched atmosphere. Thus, it is essential that patients be removed from the site of the fire whenever practical.

Note that, where a nonambulatory patient is connected to a burning piece of therapy equipment, it might be more practical, as the initial step, to remove the equipment or extinguish the fire, or both, than to remove the patient.

**B.11.3.5.2** The large quantities of noxious gases produced constitute a threat to life from asphyxia, beyond the thermal burn problem.

**B.11.3.5.2.1** Personnel are cautioned not to remain in the fire area after patients are evacuated if quantities of gaseous combustion products are present.

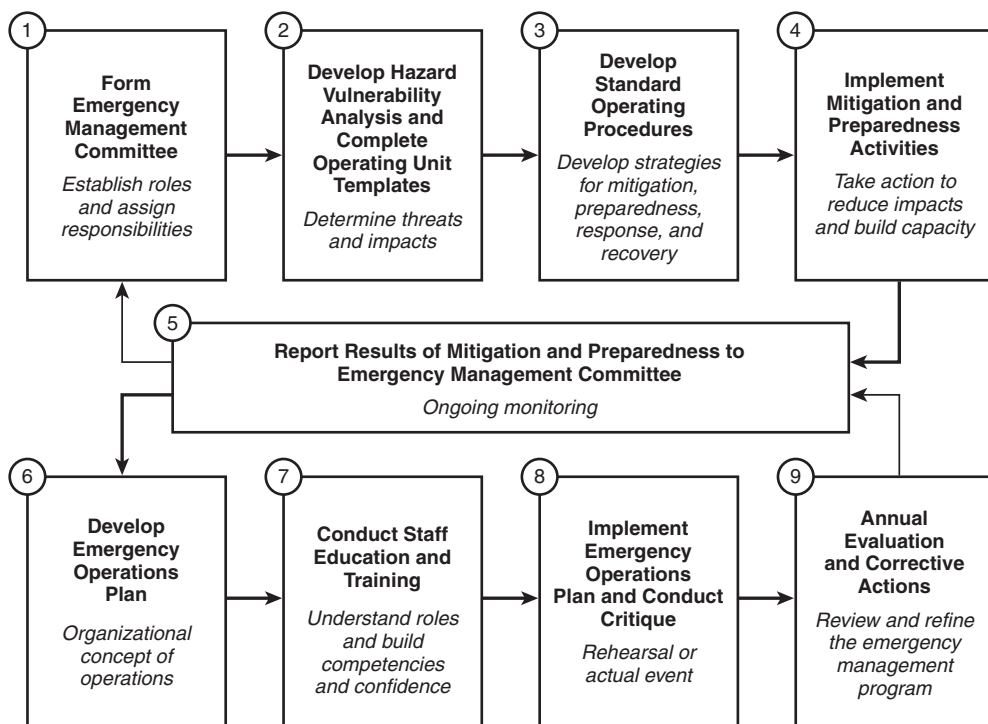
**B.11.3.6 Indoctrination of Personnel.** It is highly desirable that personnel involved in the care of patients, including nurses, aides, ward secretaries, and physicians, irrespective of whether or not they are involved in respiratory therapy practices, be thoroughly indoctrinated in all aspects of fire safety, including the following:

- (1) Location of zone valves of nonflammable medical gas systems where employed, and the station outlets controlled by each valve
- (2) Location of electrical service boxes and the areas served thereby
- (3) Location of fire extinguishers, indications for their use, and techniques for their application
- (4) Recommended methods of evacuating patients and routes by which such evacuation is accomplished most expeditiously, with reference made to the facility's fire plan
- (5) Steps involved in carrying out the fire plan of the hospital
- (6) Location of fire alarm boxes, or knowledge of other methods, for summoning the local fire department

**B.11.4 Typical Gas Cylinders.** See Table A.11.3.1.

**B.12 Additional Information on Chapter 12.**

**B.12.1 Emergency Management Program Development.** The program development process illustrated in Figure B.12.1 is an example of a tool that can be used to develop an emergency management program; other tools or processes are acceptable as long as the tasks of identification, planning, education, evaluation, and improvement are addressed.



**FIGURE B.12.1** Emergency Management Program Development Process.

### **B.12.1.1 Program Development Steps and Activities.**

**B.12.1.1.1 Review the Hazard Vulnerability Analysis (HVA) and Determine Priorities for Developing Standard Operating Procedures (SOPs).** Using the input submitted by operating unit managers, the Emergency Management Committee (EMC) must prioritize threats/events and develop a list of SOPs that must be developed to address those hazards. Figure B.12.1.1.1 displays a sample standard operating procedure format.

**B.12.1.1.2 Implement Mitigation and Preparedness Strategies.** Using the SOPs developed for prioritized threats/events, develop and implement actions that will eliminate or reduce the impact of adverse events to the facility and build capabilities to manage them. The committee should review the SOPs to identify resources needed for mitigation and preparedness, develop cost estimates or resources required, and submit the resource request to the director for funding. The committee is responsible for tracking mitigation and preparedness planning activities until completed.

**B.12.1.1.3 Report Results of Mitigation and Preparedness Activities to the Emergency Management Committee.** Operating unit managers and the emergency program coordinator should regularly report results of mitigation and preparedness activities to the committee. Reports should include mitigation activities taken that effectively reduced or eliminated adverse impacts to the facility; mitigation activities that did not reduce or eliminate adverse impacts to the facility operation; and recommendations for mitigation and preparedness activities, budget, and timelines.

**B.12.1.1.4 Develop, Publish, and Distribute the Emergency Operations Plan (EOP).** *NFPA 1600, Standard on Disaster/Emergency Management and Business Continuity Programs*, Section 3.6, describes four types of planning: strategic administrative (preparedness) planning, mitigation planning, recovery planning, and emergency operations planning.

The Federal Emergency Management Agency, now part of the Department of Homeland Security, issues guidance on the development of emergency operations plans, or EOPs. The EOP is designed to address all hazards, and it accomplishes this through its organization by functions, not departments, hazards, or individuals. Flexibility is a key feature of this type of format, as only the functions needed to address the problems are activated, not the entire plan. This type of EOP format (a basic plan and functional annexes) is that used by communities, states, and the Federal Response Plan. (*See Annex D.*)

**B.12.1.1.5 Train Staff on the EOP.** See 12.5.3.5.

**B.12.1.1.6 Delegate the Emergency Management Committee (EMC), Identify Department Roles, and Assign Responsibilities.** The EMC is a multidisciplinary committee established to coordinate and oversee the emergency management program and should have a close relationship with the Safety Committee or Environment of Care Committee, or both.

The functions of the EMC include defining the role of the organization in the communitywide emergency management program; conducting/reviewing a hazard vulnerability analysis (HVA), which addresses all hazards that threaten the facility; developing/reviewing standard operating procedures (SOPs) that address hazards identified in the HVA; developing/reviewing the emergency operations plan and coordinating it with other health care organizations in the communitywide emergency management program; assigning roles and responsibilities of operating unit

managers and key operators/managers; overseeing the development and maintenance of the EMP; ensuring that all employees have received appropriate training; conducting an annual evaluation of the effectiveness of the program; and ensuring a telephone roster of key personnel responsible for critical operations is kept current.

**B.12.1.1.7 Test and Evaluate the EOP in Response to a Drill or Actual Event.** See 12.5.3.3.7.

**B.12.2 Personnel Notification and Recall.** Medical staff, key personnel, and other personnel needed will be notified and recalled as required. In order to relieve switchboard congestion, it is desirable to utilize a pyramidal system to recall individuals who are off duty or otherwise out of the facility. Under the pyramidal system, an individual who has been notified will notify two other individuals, who, in turn, will each notify two other individuals, and so on. A current copy of the notification and recall roster, with current home and on-call telephone numbers, will be maintained at the hospital switchboard at all times. In case the pyramidal system is to be utilized, each individual involved in the system has to maintain a current copy of the roster at all times, in order that each knows who they are to notify and the telephone numbers concerned. It is essential that key personnel rosters be kept current.

### **B.12.3 Special Considerations and Protocols.**

**B.12.3.1 Fire and Explosion.** In the event that the health care facility does not need to be completely evacuated immediately, the actions staff should take when they are alerted to a fire are detailed in Sections 18.7, 19.7, 20.7, and 21.7 of *NFPA 101, Life Safety Code*.

**B.12.3.2** During the past decade, the health care industry has been struck by numerous natural disasters. A study of these disasters has provided a series of “lessons learned.” Examples follow.

**B.12.3.2.1 Alert.** Alerting is often provided through the local Office of Emergency Management and the National Oceanic and Atmospheric Administration. Based on the facility’s geographical location, these alerts often come in the form of a “watch,” which indicates the strong possibility of a natural disaster, or a “warning,” which indicates the immediate threat of a disaster. A hazard vulnerability analysis (HVA) of the area would result in actions that should be taken at different stages of the alert. Such actions could indicate monitoring reports by a liaison with the Office of Emergency Management; the Inter-national Incident Command of a facility would assess existing staffing and supply issues and make decisions to activate staff call-back plans and augment critical supplies. Some facilities have also indicated they have found it useful to complete a pre-storm patient census reduction to discharge, where possible, or to move preselected high-acuity patients, such as neonatal intensive care patients, bariatric patients, or patients with severe respiratory complications, or a combination thereof. Also, during this pre-storm patient relocation, selected patients could be moved to what are considered to be safer areas within the facility.

Some natural disasters provide absolutely no warning, such as an earthquake. During such a situation, staff would have to assume immediate operations plan procedures.

**B.12.3.2.2 Isolation Survival for up to 96 Hours.** Recent disasters have shown it could be 96 hours (in some cases, longer) before outside help is able to reach the facility. Those facilities with sufficient resources in-house for critical areas fared the best during disasters. Facilities that had corporate structures or associations with out-of-area organizations also received help in a timely manner.

\_\_\_\_\_  
(Name of Facility)

Standard Operating Procedure #: \_\_\_\_\_ (Date) \_\_\_\_\_

SUBJECT: \_\_\_\_\_  
(Insert Hazard, Threat, or Event Name)

1. Description of hazard, threat, or event: \_\_\_\_\_  
\_\_\_\_\_  
\_\_\_\_\_

2. Impact on mission-critical systems: \_\_\_\_\_  
\_\_\_\_\_  
\_\_\_\_\_

3. Operating units and key personnel with responsibility: \_\_\_\_\_  
\_\_\_\_\_  
\_\_\_\_\_

4. Mitigation and preparedness activities

a. Hazard reduction strategies and resource issues: \_\_\_\_\_  
\_\_\_\_\_

b. Preparedness strategies and resource issues: \_\_\_\_\_  
\_\_\_\_\_

5. Response and recovery activities

a. Hazard control strategies and resource issues: \_\_\_\_\_  
\_\_\_\_\_

b. Hazard monitoring strategies: \_\_\_\_\_  
\_\_\_\_\_

c. Recovery strategies and resource issues: \_\_\_\_\_  
\_\_\_\_\_

6. Notification procedures

a. Internal: \_\_\_\_\_  
\_\_\_\_\_

b. External: \_\_\_\_\_  
\_\_\_\_\_

7. Specialized staff training: \_\_\_\_\_  
\_\_\_\_\_  
\_\_\_\_\_

8. References and further assistance: \_\_\_\_\_  
\_\_\_\_\_  
\_\_\_\_\_

9. Review date: \_\_\_\_\_

\_\_\_\_\_  
(Name) (Position/Title)

© 2011 National Fire Protection Association NFPA 99

FIGURE B.12.1.1.1 Sample Standard Operating Procedure Format.

**B.12.3.2.3 Wind.** When wind knocked down communications antennas, the result was severe difficulties in facility communication with staff, other health care facilities, and so forth. One solution was construction of antennas with hinges so they could be laid down during a pre-storm warning. In other cases, the history of high winds or the HVA, or both, showed that certain windows should be boarded and certain doors should be braced and sand-bagged.

**B.12.3.2.4 Flooding.** Flooding into a facility's lower levels where utilities are often housed results in a disruption of these services. In a recovery effort, the following procedures were helpful:

- (1) Keep the electrical service turned off until the electrical device completely dries.
- (2) Secure environmental waste containers and portable medical gas containers.

One contractor dealing with the hospitals of the Gulf states stated that, based on its experience with floods, it would never again use "fail return" elevators to a basement level. Many times elevators returned to the basement level upon loss of power, resulting in the wires that are located in the cab flooring being soaked, rendering the elevator useless.

**B.12.3.2.5 Power Loss.** Power is lost typically as a result of high winds and flooding. Generators and transfer switches have been lost due to their location below the high water mark. Another problem surfacing with generators is that they often were not powerful enough to provide HVAC services to the facility. In some of the Gulf states, this alone forced evacuation of the hospital or long-term care facility. Another problem encountered was fuel, designed for another type of generator (such as military), contaminating the unit. When ordering backup generators, it is important to know the size needed and the method to be used to connect the generator to the facility.

Services, in priority, which should be up and running for the facility to be operational, are as follows:

- (1) Clinical care:
  - (a) Life-support systems
  - (b) Life safety (exits and fire alarm and fire suppression)
  - (c) Lab services
  - (d) Pharmaceutical services
  - (e) Diagnostic services
- (2) Infrastructure:
  - (a) Heating, ventilation, and air-conditioning
  - (b) Water supply and removal systems
  - (c) Information technology
  - (d) Food and liquids
  - (e) Elevators

**B.12.3.2.6 Loss of Communications.** Loss of communications is one of the major problems during a disaster. There have been many suggested solutions, including satellite phones and websites to communicate to staff and responsible parties. A successful solution has been communications conducted through Amateur Radio Emergency Services (ARES). Health care facilities have also reported that it was important to have either a liaison to, or a liaison position within, the community emergency operations center.

**B.12.3.2.7 Loss of Water.** Loss of water can result in problems with sewer service, air-conditioning, generator and refrigeration cooling systems, sterilization, dialysis services, liquid consump-

tion, laundry, dishwashing, staff and patient hygiene, and fire suppression. It is recommended that hospitals perform risk assessments in these areas and prepare themselves for 96 hours of isolation, without outside water delivery. If this is not possible, evacuation might have to be considered.

**B.12.3.2.8 Staff Issues.** The following staff issues were found to be important to address:

- (1) Transportation, including knowledge of which roads are open and actually transporting staff to the facility
- (2) Addressing the safety of families of staff
- (3) Provision of food, liquids, and lodging for staff and family members

**B.12.3.2.9 Civil Disturbance.** Civil disturbance resulted mostly from members of the disaster-struck community seeking drugs, food, and shelter. During such disturbances, facilities initiate lockdown procedures and request local police assistance to protect the facility. It was noted that police departments were often overburdened during disasters that involved civil disturbance, and facilities had to rely on private security or the National Guard, or both.

**B.12.3.2.10 Influx of Patients.** Even though the facility is trying to keep its patients alive and safe, it must be recognized that some outside patients might come to the facility due to serious injuries that occur during the disaster or other medical needs. Others might have power at home or home health care providers to assist them with special needs and may not need to go to the health care facility. Community members might come to the facility simply to seek shelter or medications in the event their normal pharmacy is shut down. Some patients might come from an evacuating facility.

Recognizing these situations, facilities might be able to redirect the special needs population to a special needs shelter if the community has set up such provisions. It was found helpful to establish an outside (under cover) pre-emergency/triage room to relieve stress from the critical care emergency room within the hospital.

**B.12.3.2.11 Evacuation.** Often evacuation was accomplished in two phases. Phase I was a pre-storm evacuation. It was found that, if this was going to be undertaken, it had to begin early enough to avoid traffic congestion to get patients to their ultimate destination in an acceptable length of time; otherwise, Phase II, or full hospital evacuation, could not take place until the disaster had subsided and transportation was once again available to move patients. Additional problems occurred with tracking patients and moving their medical records. Medical records that were on the Electronic Health Records System were at times unattainable if they could not be accessed from a remote site. Hard copy records, in some cases, were lost during transport.

**B.12.3.3 Evacuation.** Evacuation can be partial or total. It might involve moving from one story to another, from one lateral section or wing to another, or moving out of the structure. Even partial evacuations can involve all categories of patients. Where patients are those who would not routinely be moved, extraordinary measures might be required to support life. It is also necessary to ensure movement of supplies in conjunction with any evacuation. Decisions to evacuate might

be made as a result of internal problems or under the menace of engulfing external threats. In all cases, the following considerations should govern:

- (1) Move to predesignated areas, whether in the facility, nearby, or in remote zones. Evacuation directives will normally indicate destinations. Note that it is recommended to predesign a mutual aid evacuation plan with other health care facilities in the community. (See Annex D, U.S. Government Publication 3152, *Hospitals and Community Emergency Response — What you Need to Know*, on the subject of health care community mutual aid and evacuation planning.)
- (2) Ensure movement of equipment, supplies, and medical records to accompany or meet patients and staff in the new location.
- (3) Execute predetermined staffing plans. Some staff will accompany patients; others will rendezvous in the new location. Maintenance of shifts is more complex than normal, especially when some hard-to-move patients stay behind in the threatened location, and when staff might be separated from their own relocated families.
- (4) Protect patients and staff (during and after movement) against the threatening environment.
- (5) When planning, consider transportation arrangements and patient tracking.

**B.12.3.3.1** The Emergency Management Committee oversees the HVA process to ensure that all major threats to the facility are accounted for and assessed. Input to the HVA by operating unit managers is very important. Once a list of priority hazards, threats, and events has been compiled, managers should complete an operating unit template for their particular service or department. Some threats to individual operating units are so severe that they might interrupt the continuity of critical operations in the facility. The operating unit template is a unit level contingency plan, useful in staff education, drills, and actual events. Figure B.12.3.3.1(a) illustrates a sample HVA format. Figure B.12.3.3.1(b) shows a sample operating unit template.

**B.12.3.4 Activation of Emergency Utility Resources.** Loss of utility resources can occur at any time due to a natural disaster, an internal system failure, or even a supply shortage. Redundancy in system design and support is fundamental to avoiding loss of utilities. Critical points of failure in systems and supply chains should be identified, and their malfunction, disruption, or loss mitigated.

The key to a successful response to a loss of utilities is planning. Assessment of the organization's utility systems is an excellent starting point and should consist of identifying essential utility systems, such as electricity, water/sewer, piped medical gas and vacuum systems, HVAC systems, and vertical and horizontal transports. Once the systems are identified, they should be broken down to the component level and evaluated for importance. This allows the organization to establish priorities and the capabilities of the systems and their components.

Organizations should evaluate their self sufficiency for at least 96 hours. This evaluation will assist in establishing gaps in the utility systems. For example, if a facility loses electricity and has backup generators, the organization must establish how long it can operate on those generators. By looking at different components of the generator system, the organization might determine that only enough fuel for 24 hours is maintained. If the same generator is cooled by water and the water

supply is disrupted, that is an additional limitation. This concept should be applied to all systems and key components of each utility.

By establishing the limitations of the utility systems and components, an organization can identify the need to mitigate with alternative means, such as extra equipment, generators, bottled medical gas, bottled water, or formal documented agreements and understandings with other organizations. Contingency plans should be established and tested for effectiveness on a regular basis. It is essential that an organization understands its limitations and uses this information to determine if it can sustain itself for 96 hours or if it is appropriate to stop or limit services.

**B.12.3.5 Civil Disturbance.** Large-scale civil disturbances have shown that health care facilities and their personnel are not immune to the direct effects of human violence during such disturbances. Hospitals in large urban areas have to make special provisions in their disaster plans to ensure the physical safety of their employees in transit from the hospital exit to and from a secure means of transportation to their homes. In extreme cases, it might be necessary to house employees within the health care facility itself during such civil disturbances. Another aspect of civil disturbances not to be overlooked in facility security planning is the possibility that a given health care facility might have to admit and treat large numbers of prisoners during such emergencies; however, security guards for such patients will normally be provided by the local police department.

**B.12.3.6 Hazardous Materials.** There are at least three major sources of concern with regard to nonradioactive hazardous materials unrelated to the intentional use of chemical agents to harm people (*see B.12.3.8*). The first is the possibility of a large spill or venting of hazardous materials near the facility; this is especially likely near major rail or truck shipping routes, near pipelines, or near heavy manufacturing plants. Second, every facility contains within its boundaries varying amounts of such materials, especially in the laboratory and custodial areas. A spill of a highly volatile chemical can quickly contaminate an entire structure by way of the air ducts. Finally, contaminated patients can pose a risk to staff, though on a more localized basis. Usually, removal of their clothing will reduce the risk materially. In any case, staff has to be prepared to seek advice on unknown hazards. This type of advice is not usually available from poison centers, but rather from a central referral, such as CHEMTREC, and its toll-free emergency information service number (800-424-9300).

See Annex D for publications concerning hazardous materials regulations and reports on various types of chemical protective equipment.

**B.12.3.7 Volcanic Eruptions.** Although most of the direct effects of a volcanic eruption are covered in other protocols for disasters (e.g, fire, explosion), it is necessary to make special provisions for functioning in areas of heavy to moderate ash fall. This hazard can exist hundreds of miles downwind from the eruption.

Volcanic ash is actually finely pulverized rock blown out of the volcano. Outside the area of direct damage, the ash varies from a fine powder to a coarse sand. General housekeeping measures can exclude much ash. It should be noted, however, that people move about freely during and after ash fall.



Operating Unit: \_\_\_\_\_ Operating Unit Manager: \_\_\_\_\_

Mission-Critical System	Potential Problems	Contact for Assistance in Preparing	Mitigation Actions	If this mission-critical system is interrupted, then:	
				Assess situation for:	Action required:
(Lighting)					
(Electrical Power)					
(Steam Distribution)					
(HVAC)					
(Room or Hood Exhaust)					
(Water Delivery)					
(Waste Stream)					
(Communications)					

© 2011 National Fire Protection Association NFPA 99

FIGURE B.12.3.3.1(b) Sample Operating Unit Template.

Ash fall presents the following four problems for health care facilities:

- (1) People require cleanup (brushing, vacuuming) before entering the building.
- (2) Electromechanical and automotive equipment and air-filtering systems require special care because of the highly abrasive and fine-penetration nature of the ash.
- (3) Increased flow of patients with respiratory complaints can be expected.
- (4) Eye protection is required for people who have to be out in the dust. (No contact lenses should be worn; goggles are suggested.) Dust masks are available that are approved by the National Institute for Occupational Safety and Health (NIOSH) and are marked TC-21 plus other digits.

**B.12.3.8 Weapons of Mass Destruction.** Weapons of mass destruction, or WMD, are defined as any weapon or device that is intended to cause, or has the capability to cause, death or serious bodily injury to a significant number of people through the release, dissemination, or impact of toxic or poisonous chemicals or their precursors; a disease organism; or radiation or radioactivity. A complete index of chemical, biological, and radiological agents and treatment recommendations can be found at the following web site: <http://www.bt.cdc.gov/agent/index.asp>. Many federal departments and agencies are involved in supporting WMD preparedness and response activities at the state and local level. The Department of Health and Human Services manages two cooperative grant programs administered by the Centers for Disease Control and Prevention (CDC) and the Assistant Secretary for Preparedness and Response (ASPR). These programs are aimed at enhancing the readiness of the public health and hospital system. The following web link describes these initiatives: [http://www.bt.cdc.gov/planning/continuationguidance/pdf/activities\\_attachments.pdf](http://www.bt.cdc.gov/planning/continuationguidance/pdf/activities_attachments.pdf).

The Department of Justice maintains a help line (1-800-368-6498) offering technical assistance in nonemergency cases and provides information on the following subjects: detection equipment; personal protective equipment; decontamination systems and methods; physical properties of WMD materials; signs and symptoms of WMD exposure; treatment of exposure to WMD materials; toxicology information; federal response assets; and applicable laws and regulations. For reporting actual or potential acts of terrorism, health care facilities should contact their local or state health departments. The National Response Center (1-800-424-8802) can link callers to technical experts.

See Annex D for publications relating to WMD preparedness for health systems.

**B.12.4 Continuing Operations Plan and Recovery.** It has been well documented that a community cannot recover without the health care facilities recovering simultaneously or beforehand. If at all possible, a health care facility needs to remain operational throughout a disaster to care for its patients, as well as for those who are injured during the disaster.

It is important to advertise that the facility is open for business as soon as it is able to operate.

As part of disaster recovery, health care facilities should consider the following:

- (1) Know the sources of funding, such as insurance and FEMA, and request loans from those sources to initiate cash flow as soon as possible.
- (2) Activate lines of credit with vendors and banks.

- (3) Use stock and other investments as collateral for loans and lines of credit.
- (4) Have the finance section chief of the Incident Command System work with other section chiefs to keep precise records of disaster-related expenses for reimbursement following the disaster.
- (5) Ensure that doctors' offices open simultaneously with the opening of the hospital to provide services to patients. Provide office support as soon as possible for physicians, with the priority being emergency department physicians, general practitioners, orthopedic surgeons, and cardiovascular surgeons.
- (6) Activate billing and payroll as soon as possible.
- (7) Consider setting up a bank within the hospital for staff.

Credits:

Educational Fact Finding and On-site Research in Houston, Texas, following Tropical Storm Allison, 2001.

National Fire Protection Association.

Russell Phillips & Associates, LLC.

Also see "Atmospheric Pressure," *Fire Journal*, July–August, 2002.

Educational Fact Finding and On-site Research for Hurricane Katrina, Louisiana, Mississippi, 2005.

American Society of Healthcare Engineers: Dale Woodin.

Russell Phillips & Associates, LLC: Russell Phillips & Scott Aronson.

## **B.13 Reserved.**

## **B.14 Additional Information on Chapter 14.**

### **B.14.1 Nature of Hazards.**

#### **B.14.1.1 Fire and Explosion.**

**B.14.1.1.1** The occurrence of a fire requires the presence of combustible or flammable materials, an atmosphere containing oxygen or other oxidizing agent(s), and heat or energy source of ignition.

Note that certain substances such as acetylenic hydrocarbons can propagate flame in the absence of oxygen.

**B.14.1.1.2** Under hyperbaric conditions utilizing compressed air, the partial pressure of oxygen is increased. Leakage of oxygen into the atmosphere of the chamber (for example, from improper application of respiratory therapy apparatus) can further increase markedly the oxygen partial pressure.

**B.14.1.1.2.1** The flammability or combustibility of materials generally increases as the partial pressure of oxygen increases, even when the percentage of oxygen in the gas mixture remains constant. Materials that are nonflammable or noncombustible under normal atmospheric conditions can become flammable or combustible under such circumstances.

#### **B.14.1.1.3 Sources of Fuel.**

**B.14.1.1.3.1** Materials that might not ignite in air at atmospheric pressure or require relatively high temperatures for their ignition but that burn vigorously in 100 percent oxygen include, but are not necessarily limited to, the following: tri-cresyl phosphate (lubricant); certain types of flame-resistant fabrics; silicone rubber; polyvinyl chloride; asbestos-containing paint; glass fiber-sheathed silicone rubber-insulated wire; polyvinyl chloride-insulated asbestos-covered wire and sheet; polyamides; epoxy compounds; and certain asbestos blankets.



Note that flammable lubricants are used widely in equipment designed for conventional use, including shafts, gear boxes, pulleys and casters, and threaded joints, which are coupled and uncoupled.

**B.14.1.1.3.2** The flammability of certain volatile liquids and gases containing carbon and hydrogen is well known. Hazards and safeguards for their use in oxygen-enriched atmospheres at ambient pressure are well-documented in 13.4.1 of NFPA 99. See also NFPA 325, *Guide to Fire Hazard Properties of Flammable Liquids, Gases, and Volatile Solids*, now part of the NFPA *Fire Protection Guide to Hazardous Materials*.

Note that repeated reference to subsection 13.4.1 is made throughout Chapter 14. These references do not imply, and should not be construed to mean, that flammable anesthetics can or should be employed in or around hyperbaric facilities.

**B.14.1.1.3.3** Human tissues will burn in an atmosphere of 100 percent oxygen. Body oils and fats, as well as hair, will burn readily under such circumstances.

**B.14.1.1.3.4** When a conventional loose cotton outer garment, such as scrub suits, dresses, and gowns employed in hospital operating suites, is ignited in an atmosphere of pure oxygen, the garment will become engulfed in flame rapidly and will be totally destroyed within 20 seconds or less.

If such a garment is ignited in a compressed air atmosphere, the flame spread is increased. When oxygen concentration exceeds 23.5 percent at elevated total pressure, flame spread is much more rapid, and at 6 ATA, is comparable to  $95 \pm 5$  percent at 1 ATA. Flame spread in air (21 percent oxygen) is somewhat increased at 6 ATA, but not to the level of  $95 \pm 5$  percent at 1 ATA.

Combustible fabrics have tiny air spaces that become filled with oxygen when exposed to oxygen-enriched environments. Once removed to atmospheric air (e.g., room air outside the chamber), the fabric will burn, if ignited, almost as rapidly as if it were still in the oxygen environment. This hazard will remain until the oxygen trapped in the air spaces in the fabric has had time to diffuse out and be replaced by air.

**B.14.1.1.3.5** Oil-based or volatile cosmetics (facial creams, body oils, hair sprays, and the like) constitute a source of fuel that is highly flammable in an oxygen-enriched atmosphere.

#### **B.14.1.1.4 Sources of Ignition.**

**B.14.1.1.4.1** Sources of ignition that might be encountered in a hyperbaric chamber include, but are not necessarily limited to, the following: defective electrical equipment, including failure of high-voltage components of radiological or monitoring equipment; heated surfaces in broken vacuum tubes or broken lamps used for general illumination, spot illumination, or illumination of diagnostic instruments; the hot-wire cautery or high-frequency electrocautery; open or arcing switches, including motor switches; bare defibrillator paddles; overheated motors; and electrical thermostats.

**B.14.1.1.4.2** Sources of ignition that should not be encountered in a hyperbaric facility, but that might be introduced by inept practice, include the following: lighted matches or tobacco, static sparks from improper use of personal attire, electrical wiring not complying with 14.2.7, cigarette lighters, and any oil-contaminated materials that present a spontaneous heating hazard.

**B.14.1.1.4.3** In oxygen-enriched atmospheres, the minimum energy necessary to ignite flammable or combustible materials is reduced in most instances below the energy required in atmospheres of ambient air.

#### **B.14.1.2 Mechanical Hazards.**

##### **B.14.1.2.1 General.**

**B.14.1.2.1.1** A large amount of potential energy is stored in even a small volume of compressed gas. In hyperbaric chambers of moderate or large size, the potential energy of the chamber's compressed atmosphere, if released suddenly, can produce devastating destruction to adjacent structures and personnel, as well as to structures and personnel remote from the site of the chamber. Such sudden release could result from failure of the vessel structure, its parts, or its piping.

**B.14.1.2.1.2** A particular hazard can be created if individuals attempt to drill, cut, or weld the vessel in a manner contrary to ASME *Boiler and Pressure Vessel Code*.

**B.14.1.2.2** The restriction on escape and the impedence to rescue and fire-fighting efforts posed by the chamber create a significant hazard to life in case of fire or other emergency.

**B.14.1.2.2.1** A particular hazard exists to chamber personnel in the event of a fire within the structure housing the chamber. Inability to escape from the chamber and loss of services of the chamber operator would pose serious threats to the lives of all occupants of the chamber.

**B.14.1.2.2.2** All personnel involved in hyperbaric chamber operation and therapy, including patients and family, have to be made aware of the risks and hazards involved. Fire prevention is essential. Extinguishment of a fire within a Class B chamber is impossible. Extinguishment of a fire within a Class A chamber is only possible utilizing equipment already installed in such a chamber, and then often only by the efforts of the occupants of such a chamber or the chamber operator.

**B.14.1.2.3** The necessity for restricting viewing ports to small size limits the vision of chamber operators and other observers, reducing their effectiveness as safety monitors.

**B.14.1.2.4** Containers and enclosures can be subjected to collapse or rupture as a consequence of the changing pressures of the hyperbaric chamber. Items containing entrained gas include, but are not necessarily limited to, the following: ampuls, partially filled syringes, stoppered or capped bottles, cuffed endotracheal tubes, and pneumatic cushions employed for breathing masks or aids in positioning patients. The rupture of such containers having combustible or flammable liquids would also constitute a severe fire or explosion hazard.

**B.14.1.2.4.1** The sudden collapse of containers from high external pressures will result in adiabatic heating of the contents. Therefore the collapse of a container of flammable liquid would constitute a severe fire or explosion hazard both from heating and from a spill of the liquid. (See 14.3.1.5.2 and B.14.1.1.3.2.)

**B.14.1.2.5** Other mechanical hazards relate to the malfunction, disruption, or inoperativeness of many standard items when placed in service under pressurized atmospheres.

Hazards that might be encountered in this regard are implosion of illuminating lamps and vacuum tubes; overloading of fans driving gas at higher density; and inaccurate operation of standard flowmeters, pressure gauges, and pressure-reducing regulators.

Note that illuminating lamps or vacuum tubes, which implode, or overloaded fans, are sources of ignition.

### **B.14.1.3 Pathophysiological, Medical, and Other Related Hazards.**

**B.14.1.3.1** Exposure of pregnant chamber occupants to hyperbaric atmospheres might result in fetal risk.

**B.14.1.3.2** Medical hazards that can be encountered routinely include compression problems, nitrogen narcosis, oxygen toxicity, and the direct effects of sudden pressure changes.

**B.14.1.3.2.1** Inability to equalize pressure differentials between nasopharynx (nose) and nasal sinuses or the middle ear can result in excruciating pain and might cause rupture of the eardrum or hemorrhage into the ear cavity or nasal sinus.

**B.14.1.3.2.2** The breathing of air (78 percent nitrogen) under significant pressures (as by chamber personnel breathing chamber atmosphere) can result in nitrogen narcosis, which resembles alcoholic inebriation. The degree of narcosis is directly related to the amount of pressurization. Nitrogen narcosis results in impairment of mental functions, loss of manual dexterity, and interference with alertness and ability to think clearly and act quickly and intelligently in an emergency.

**B.14.1.3.2.3** Oxygen toxicity can develop from breathing oxygen at partial pressures above 0.50 atmospheres absolute for a significant length of time. Oxygen toxicity can affect the lungs (pain in the chest, rapid shallow breathing, coughing), nervous system (impaired consciousness and convulsions), or other tissues and organs, or combinations thereof.

**B.14.1.3.2.4** Direct effects of reduction in pressure can include inability to equalize pressures between the nasopharynx and sinuses or middle ear, expansion of gas pockets in the gastrointestinal tract, and expansion of trapped gas in the lungs.

**B.14.1.3.2.5** The presence of personnel within the cramped confines of the hyperbaric chamber in close proximity to grounded metallic structures on all sides creates a definite shock hazard if accidental contact is made with a live electrical conductor or a defective piece of electrical equipment. Such accidental contact also could be a source of ignition of flammable or combustible materials. (See B.14.1.1.4.)

**B.14.1.3.3** Medical hazards that are not ordinarily encountered during hyperbaric oxygen therapy, but that might arise during malfunction, fire, or other emergency conditions, include electric shock and fouling of the atmosphere of the chamber with oxygen, nitrous oxide, carbon dioxide, carbon monoxide, pyrolysis products from overheated materials, or the toxic products of combustion from any fire.

**B.14.1.3.3.1** Increased concentrations of carbon dioxide within the chamber, as might result from malfunction of the systems responsible for monitoring or removal thereof, can be toxic under increased pressures.

**B.14.1.3.3.2** The development of combustion products or gases evolved from heated nonmetals within the closed space of the hyperbaric chamber can be extremely toxic to life because of the confining nature of the chamber and the increased hazards of breathing such products under elevated pressure.

Note that extreme pressure rises have accompanied catastrophic fires in confined atmospheres. These pressures have driven hot, toxic gases into the lungs of victims as well as exceeding the structural limits of the vessel in at least one case.

**B.14.1.3.4** Physiological hazards include exposure to high noise levels and decompression sickness. Rapid release of pressurized gases can produce shock waves and loss of visibility.

**B.14.1.3.4.1** During hyperbaric therapy, and especially during compression, the noise level within the chamber becomes quite high. Such a level can be hazardous because it is distracting, interferes with communication, and can produce permanent sensory-neural deafness.

**B.14.1.3.4.2** Decompression sickness (bends, caisson worker's disease) results from the elution into the bloodstream or extravascular tissues of bubbles of inert gas (mainly nitrogen) that becomes dissolved in the blood and tissue fluids while breathing air at elevated pressures for a significant period of time.

Note that rapid decompression of the chamber can occur if the pressure relief valve is damaged from exposure to a fire external to the chamber or from the venting of hot products of combustion from within the chamber.

**B.14.1.3.4.3** The use of decompression procedures will prevent immediate escape from the Class A chamber by occupants during emergency situations.

Note that these procedures are not followed if chamber occupants are exposed to a "no-decompression exposure" [compression to less than 2 atmospheres absolute (ATA) air], or when compressed to 2 ATA or higher pressures and breathing 100 percent oxygen.

**B.14.1.3.4.4** The sudden release of gas, whether by rupture of a container or operation of a device such as used in fire fighting, will produce noise, possible shock waves, reduced or obscured visibility, and temperature changes. The initial effect might be to cool the air, but resulting pressure rises will cause adiabatic heating.

**B.14.1.3.5** In summary, the hazards of fire and related problems in hyperbaric systems are real. By the very nature of the hyperbaric atmosphere, increased partial pressures of oxygen are present routinely. Flammability and combustibility of materials are increased. Ignition energy is lowered. Both immediate escape and ready entry for rescue are impeded. Finally, attendants within the chamber, through effects of the elevated noise level and nitrogen pressure, might be unable to respond to emergencies quickly and accurately.

### **B.14.2 Suggested Procedures to Follow in Event of Fire in Class A Chambers.**

**B.14.2.1 Fire Inside Chamber.** For fire inside the chamber the following procedures should be performed:

- (1) *Inside Observer:*
  - (a) Activate fire suppression system and/or hand-held hoses.
  - (b) Advise outside.
  - (c) Don breathing air mask.
- (2) *Chamber Operator:*
  - (a) Activate the fire suppression system, if needed.
  - (b) Switch breathing gas to air.
  - (c) Decompress the chamber as rapidly as possible.

- (3) *Medical Personnel (Outside):*
  - (a) Direct operations and assist crew members wherever necessary.
  - (b) Provide medical support as required.
- (4) *Other Personnel (Outside):*
  - (a) Notify the fire department by activating fire signaling device.
  - (b) Stand by with a fire extinguisher.
  - (c) Assist in unloading chamber occupants.

**B.14.2.2 Fire Outside Chamber.** For fire outside the chamber the following procedures should be performed:

- (1) *Chamber Operator:*
  - (a) Notify the inside observer to stand by for emergency return to normal atmospheric pressure.
  - (b) Notify fire department by activating fire signaling device.
  - (c) Switch breathing gas to air.
  - (d) Don the operator's source of breathable gas.
- (2) *Medical Personnel (Outside):*
  - (a) Determine whether procedure should be terminated.
  - (b) Provide medical support as required.
- (3) *Other Personnel (Outside):*
  - (a) Stand by with a fire extinguisher.
  - (b) Assist in unloading chamber occupants.

**B.14.3 Suggested Procedures for Hyperbaric Chamber Operator to Follow in Event of Fire in Class B Chambers.**

**B.14.3.1** For fires within the facility not involving the chamber, the following procedure should be performed:

- (1) If there is smoke in the area, don the operator's source of breathable gas.
- (2) Decompress the chamber. The urgency of decompression should be determined by the location of the fire.

- (3) Remove the patient and evacuate to safe area.
- (4) Turn off the oxygen zone valve to the chamber room and close any smoke/fire barrier doors. These steps are consistent with the Rescue and Confine elements of the Rescue, Alarm, Confine, Extinguish (R.A.C.E.) procedure. It is assumed that other personnel will evacuate other patients and visitors from the area and activate a fire alarm signaling device (if not already activated).

**B.14.3.2** For fire within the chamber, the following procedure should be performed:

- (1) Stop oxygen from flowing into the chamber by switching off the chamber (if the chamber is compressed with oxygen) or switching the supply gas of a breathing device from oxygen to air (if the chamber is compressed with air).
- (2) Decompress the chamber as rapidly as possible.
- (3) Stand by with a hand-held fire extinguisher and spray into the chamber (if necessary) when the chamber door is opened.
- (4) Remove the patient and evacuate to a safe area.
- (5) Turn off the oxygen zone valve to the chamber room and close any smoke/fire barrier doors.

These steps are consistent with the Rescue and Confine elements of the Rescue, Alarm, Confine, Extinguish (R.A.C.E.) procedure. It is assumed that other personnel will evacuate other patients and visitors from the area and activate a fire alarm signaling device (if not already activated). The injured patient should have appropriate medical attention immediately after evacuation to a safe area. Many Class B chambers require oxygen supply pressure to operate a rapid decompression feature. If this is the case, do not turn off the oxygen zone valve or any inline oxygen supply shutoff valve until all patients have been removed from the chamber(s).

**B.14.4** See Table B.14.4.

**Table B.14.4 Pressure Table**

Atmosphere Absolute (ATA)	mm Hg	psia	psig	Equivalent Depth in Seawater		mm Hg Oxygen Pressure of Compressed Air	mm Hg Oxygen Pressure of Oxygen- Enriched Air (23.5%)
				ft	m		
1	760	14.7	0	0	0	160	179
1.5	1140	22	7.35	16.5	5.07	240	268
2.0	1520	29.4	14.7	33.1	10.13	320	357
2.5	1900	36.7	22.0	49.7	15.20	400	447
3.0	2280	44.1	29.4	66.2	20.26	480	536
3.5	2660	51.4	36.7	82.7	25.33	560	625
4.0	3040	58.8	44.1	99.2	30.40	640	714
5.0	3800	73.5	58.8	132.3	40.53	800	893

Notes:

1. The oxygen percentage in the chamber environment, not the oxygen partial pressure, is of principal concern, as concentrations above 23.5 percent oxygen increase the rate of flame spread. Thirty percent oxygen in nitrogen at 1 ATA (228 mm Hg pO<sub>2</sub>) increases burning rate. However, 6 percent oxygen in nitrogen will not support combustion, regardless of oxygen partial pressure (at 5 ATA, 6 percent oxygen gives 228 mm Hg pO<sub>2</sub>).

2. The Subcommittee on Hyperbaric and Hypobaric Facilities recommends that one unit of pressure measurement be employed. Since a variety of different units are now in use, and since chamber operators have not settled upon one single unit, the above table includes the five units most commonly employed in chamber practice.

### Annex C Sample Ordinance Adopting NFPA 99

*This annex is not a part of the requirements of this NFPA document but is included for informational purposes only.*

**C.1** The following sample ordinance is provided to assist a jurisdiction in the adoption of this code and is not part of this code.

ORDINANCE NO. \_\_\_\_\_

An ordinance of the [jurisdiction] adopting the [year] edition of NFPA [document number], [complete document title], and documents listed in Chapter 2 of that [code, standard]; prescribing regulations governing conditions hazardous to life and property from fire or explosion; providing for the issuance of permits and collection of fees; repealing Ordinance No. \_\_\_\_\_ of the [jurisdiction] and all other ordinances and parts of ordinances in conflict therewith; providing a penalty; providing a severability clause; and providing for publication; and providing an effective date.

BE IT ORDAINED BY THE [governing body] OF THE [jurisdiction]:

SECTION 1 That the [complete document title] and documents adopted by Chapter 2, three (3) copies of which are on file and are open to inspection by the public in the office of the [jurisdiction's keeper of records] of the [jurisdiction], are hereby adopted and incorporated into this ordinance as fully as if set out at length herein, and from the date on which this ordinance shall take effect, the provisions thereof shall be controlling within the limits of the [jurisdiction]. The same are hereby adopted as the [code, standard] of the [jurisdiction] for the purpose of prescribing regulations governing conditions hazardous to life and property from fire or explosion and providing for issuance of permits and collection of fees.

SECTION 2 Any person who shall violate any provision of this code or standard hereby adopted or fail to comply therewith; or who shall violate or fail to comply with any order made thereunder; or who shall build in violation of any detailed statement of specifications or plans submitted and approved thereunder; or fail to operate in accordance with any certificate or permit issued thereunder; and from which no appeal has been taken; or who shall fail to comply with such an order as affirmed or modified by a court of competent jurisdiction, within the time fixed herein, shall severally for each and every such violation and noncompliance, respectively, be guilty of a misdemeanor, punishable by a fine of not less than \$ \_\_\_\_\_ nor more than \$ \_\_\_\_\_ or by imprisonment for not less than \_\_\_\_\_ days nor more than \_\_\_\_\_ days or by both such fine and imprisonment. The imposition of one penalty for any violation shall not excuse the violation or permit it to continue; and all such persons shall be required to correct or remedy such violations or defects within a reasonable time; and when not otherwise specified the application of the above penalty shall not be held to prevent the enforced removal of prohibited conditions. Each day that prohibited conditions are maintained shall constitute a separate offense.

SECTION 3 Additions, insertions, and changes — that the [year] edition of NFPA [document number], [complete document title] is amended and changed in the following respects:

List Amendments

SECTION 4 That ordinance No. \_\_\_\_\_ of [jurisdiction] entitled [fill in the title of the ordinance or ordinances in effect at the present time] and all other ordinances or parts of ordinances in conflict herewith are hereby repealed.

SECTION 5 That if any section, subsection, sentence, clause, or phrase of this ordinance is, for any reason, held to be invalid or unconstitutional, such decision shall not affect

the validity or constitutionality of the remaining portions of this ordinance. The [governing body] hereby declares that it would have passed this ordinance, and each section, subsection, clause, or phrase hereof, irrespective of the fact that any one or more sections, subsections, sentences, clauses, and phrases be declared unconstitutional.

SECTION 6 That the [jurisdiction's keeper of records] is hereby ordered and directed to cause this ordinance to be published. [NOTE: An additional provision may be required to direct the number of times the ordinance is to be published and to specify that it is to be in a newspaper in general circulation. Posting may also be required.]

SECTION 7 That this ordinance and the rules, regulations, provisions, requirements, orders, and matters established and adopted hereby shall take effect and be in full force and effect [time period] from and after the date of its final passage and adoption.

### Annex D Informational References

**D.1 Referenced Publications.** The documents or portions thereof listed in this annex are referenced within the informational sections of this code and are not part of the requirements of this document unless also listed in Chapter 2 for other reasons.

**D.1.1 NFPA Publications.** National Fire Protection Association, 1 Batterymarch Park, Quincy, MA 02169-7471.

NFPA 10, *Standard for Portable Fire Extinguishers*, 2010 edition.

NFPA 13, *Standard for the Installation of Sprinkler Systems*, 2010 edition.

NFPA 30, *Flammable and Combustible Liquids Code*, 2012 edition.

NFPA 45, *Standard on Fire Protection for Laboratories Using Chemicals*, 2011 edition.

NFPA 49, *Hazardous Chemicals Data*, 1994 edition. (No longer in print; appears in NFPA *Fire Protection Guide to Hazardous Materials*, 13th edition, 2002.)

NFPA 53, *Recommended Practice on Materials, Equipment, and Systems Used in Oxygen-Enriched Atmospheres*, 2011 edition.

NFPA 55, *Compressed Gases and Cryogenic Fluids Code*, 2010 edition.

NFPA 54, *National Fuel Gas Code*, 2012 edition.

NFPA 58, *Liquefied Petroleum Gas Code*, 2011 edition.

NFPA 70<sup>®</sup>, *National Electrical Code*<sup>®</sup>, 2011 edition.

NFPA 72<sup>®</sup>, *National Fire Alarm and Signaling Code*, 2010 edition.

NFPA 90B, *Standard for the Installation of Warm Air Heating and Air-Conditioning Systems*, 2012 edition.

NFPA 99B, *Standard for Hypobaric Facilities*, 2010 edition.

NFPA 101<sup>®</sup>, *Life Safety Code*<sup>®</sup>, 2012 edition.

NFPA 110, *Standard for Emergency and Standby Power Systems*, 2010 edition.

NFPA 220, *Standard on Types of Building Construction*, 2012 edition.

NFPA 259, *Standard Test Method for Potential Heat of Building Materials*, 2008 edition.

NFPA 325, *Guide to Fire Hazard Properties of Flammable Liquids, Gases, and Volatile Solids*, 1994 edition. (No longer in print; appears in NFPA *Fire Protection Guide to Hazardous Materials*, 13th edition, 2002.)

NFPA 491, *Guide to Hazardous Chemical Reactions*, 1997 edition.  
NFPA 551, *Guide for the Evaluation of Fire Risk Assessments*, 2010 edition.

NFPA 704, *Standard System for the Identification of the Hazards of Materials for Emergency Response*, 2012 edition.

NFPA 730, *Guide for Premises Security*, 2011 edition.

NFPA 1600<sup>®</sup>, *Standard on Disaster/Emergency Management and Business Continuity Programs*, 2010 edition.

NFPA *Fire Protection Guide to Hazardous Materials*, 2001 edition.

#### D.1.2 Other Publications.

**D.1.2.1 ACS Publications.** American College of Surgeons, 633 N. Saint Clair Street, Chicago, IL 60611-3211. 04-GR-0001, *Guidelines for Optional Ambulatory Surgical Care and Office-Based Surgery*, 2000.

**D.1.2.2 ASHRAE Publications.** American Society of Heating, Refrigerating and Air Conditioning Engineers, Inc., 1791 Tullie Circle, NE, Atlanta, GA 30329-2305.

*ASHRAE Handbook of Fundamentals*, 2001.

**D.1.2.3 ASME Publications.** American Society of Mechanical Engineers, Three Park Avenue, New York, NY 10016-5990.

ASME B16.22, *Wrought Copper and Copper Alloy Solder Joint Pressure Fitting*, 2001.

ANSI/ASME B16.50, *Wrought Copper and Copper Alloy Braze Joint Pressure Fitting*, 2001.

*ASME Boiler and Pressure Vessel Code*, 2001.

**D.1.2.4 ASSE Publications.** American Society of Sanitary Engineering, 901 Canterbury Road, Suite A, Westlake, OH 44145-1480.

ASSE 6040, *Professional Qualification Standard for Medical Gas Maintenance Personnel*, 2001.

**D.1.2.5 ASTM Publications.** ASTM International, 100 Barr Harbor Drive, P.O. Box C700, West Conshohocken, PA 19428-2959.

ASTM D 92, *Standard Test Method for Flash and Fire Points by Cleveland Open Cup Tester*, 2002.

ASTM D 323

ASTM G 63, *Standard Guide for Evaluating Nonmetallic Materials for Oxygen Service*, 1998.

ASTM G 88, *Standard Guide for Designing Systems for Oxygen Service*, 1990.

ASTM G 93, *Standard Practice for Cleaning Methods and Cleanliness Levels for Material and Equipment Used in Oxygen-Enriched Environments*, 1996.

ASTM G 94, *Standard Guide for Evaluating Metals for Oxygen Service*, 1992.

QQ-N-290, ASTM B689, *Federal Specification: Nickel Plating (Electro Deposited)*, July 2009.

**D.1.2.6 CGA Publications.** Compressed Gas Association, 4221 Walney Road, 5th Floor, Chantilly, VA 20151-2923.

CGA G-8.1, *Standard for Nitrous Oxide Systems at Consumer Sites*, 1990.

CGA V-1, *Standard for Compressed Gas Cylinder Valve Outlet and Inlet Connections* (ANSI B57.1), 1994.

**D.1.2.7 FGI Publications.** Facility Guidelines Institute, 1919 McKinney Avenue, Dallas, TX 75201.

*Guidelines for Design and Construction of Health Care Facilities*, 2010.

**D.1.2.8 IEC Publications.** International Electrotechnical Commission, 3, rue de Varembe, P.O. Box 131, CH-1211 Geneva 20, Switzerland.

IEC, 60601-1-1, *Medical Electrical Equipment — Part 1: General Requirements for Basic Safety and Essential Performance*, 2007.

**D.1.2.9 IEEE Publications** Institute of Electrical and Electronics Engineers, Three Park Avenue, 17th Floor, New York, NY 10016-5997.

IEEE 602, *Recommended Practice for Electric Systems in Health Care Facilities*, 2007.

**D.1.2.10 Ocean Systems, Inc. Publications.** Ocean Systems, Inc., Research and Development Laboratory, Tarrytown, NY 10591. Work carried out under U.S. Office of Contract No. N00014-67-A-0214-0013.

Ocean Systems, Inc., “Technical Memorandum UCRI-721, Chamber Fire Safety.” (Figure A.3.3.14.3 is adapted from Figure 4, “Technical Memorandum UCRI-721, Chamber Fire Safety,” T. C. Schmidt, V. A. Dorr, and R. W. Hamilton, Jr., Ocean Systems, Inc., Research and Development Laboratory, Tarrytown, NY 10591. Work carried out under US Office of Naval Research, Washington, DC, Contract No. N00014-67-A-0214-0013.) (G. A. Cook, R. E. Meierer, and B. M. Shields, “Screening of Flame-Resistant Materials and Comparison of Helium with Nitrogen for Use in Dividing Atmospheres.” First summary report under ONR Contract No. 0014-66-C-0149. Tonawanda, NY: Union Carbide, 31 March 1967. DDC No. Ad-651583.)

**D.1.2.11 TIA Publications.** Telecommunications Industry Association, 2500 Wilson Boulevard, Suite 300, Arlington, VA 22201.

TIA/EIA 569-B, *Commercial Building Standard for Telecommunications Pathways and Spaces*, 2004.

**D.1.2.12 UNECE Publications.** UN Economic Commission for Europe, Information Service, Palais des Nations, CH-1211 Geneva 10, Switzerland.

UN *Recommendations on the Transport of Dangerous Goods, Model Regulations*, 11th, rev. ed.

*Manual of Tests and Criteria*, 3rd rev. ed.

**D.1.2.13 U.S. Government Publications.** U.S. Government Printing Office, Washington, DC 20402.

Biological Threat Interrogatories, <http://www.va.gov/emshg/page.cfm?ID=BioThreatInterr>.

Title 29, Code of Federal Regulations, Part 1910, Subpart 1030, *Bloodborne Pathogens*.

Title 29, Code of Federal Regulations, Part 910, Subpart 1910, *Occupational Exposures to Chemical Laboratories*.

Title 49, Code of Federal Regulations, Parts 171 through 190 (U.S. Dept. of Transportation, Specifications for Transportation of Explosives and Dangerous Articles). (In Canada, the regulations of the Board of Transport Commissioners, Union Station, Ottawa, Canada, apply.)

Title 49, Code of Federal Regulations, Part 173, *Shippers — General Requirements for Shipments and Packagings*.

Commercial Standard 223-59, *Casters, Wheels, and Glides for Hospital Equipment*.

Environmental Protection Agency, Chemical Emergency Preparedness and Prevention, <http://yosemite.epa.gov/oswer/ceppoweb.nsf/content/homelandSecurity.htm?OpenDocument>.

National Research Council Publication 1132, *Diesel Engines for Use with Generators to Supply Emergency and Short Term Electric Power*. (Also available as Order No. O.P.52870 from University Microfilms, P.O. Box 1366, Ann Arbor, MI 48106.)

U.S. Department of Defense:

U.S. Army Medical Research Institute of Chemical Defense (USAMRICD), <http://chemdef.apgea.army.mil/>.

U.S. Army Medical Research Institute of Infectious Diseases (USAMRIID), <http://www.usamriid.army.mil/general/index.html>.

U.S. Army Soldier and Biological Chemical Command (SBCCOM), <http://hld.sbcom.army.mil/ip/detectors>.

U.S. Department of Health and Human Services:

Centers for Disease Control and Prevention: HHS Publication No. 93-8395, *Biosafety in Microbiological and Biomedical Laboratories*.

Centers for Disease Control and Prevention, Public Health Preparedness and Response for Bioterrorism Program, <http://www.bt.cdc.gov/planning/continuationguidance/index.asp>.

Health Resources and Services Administration, Hospital Bioterrorism Preparedness Program, [www.hrsa.gov/bioterrorism](http://www.hrsa.gov/bioterrorism).

National Institute for Occupational Health and Safety, Personal Protection Equipment, <http://www.cdc.gov/niosh/topics/emres/ppe.html>.

Protecting Building Environments from Airborne Chemical, Biologic and Radiologic Agents (page 9). <http://www.cdc.gov/mmwr/PDF/wk/mm5135.pdf>.

U.S. Department of Homeland Security:

Capability Assessment for Readiness, <http://www.fema.gov/pdf/rrr/car.pdf>.

Exercise Design Course, <http://training.fema.gov/emiweb/IS/is120.asp>.

Federal Response Plan/National Response Plan/National Incident Management System, [www.fema.gov/rrr/frp](http://www.fema.gov/rrr/frp).

*Guide for All-Hazard Emergency Operations Planning*, <http://www.fema.gov/pdf/rrr/slg101.pdf>.

Metropolitan Medical Response System, Resources, <http://mmrs.hhs.gov/main/Resources.aspx>.

National Disaster Medical System, Conference Library, [http://ndms.dhhs.gov/NDMS%20Conference/conf2k3/previous\\_confe\\_03/previous\\_confe\\_03.html](http://ndms.dhhs.gov/NDMS%20Conference/conf2k3/previous_confe_03/previous_confe_03.html).

Strategic National Stockpile, <http://www.bt.cdc.gov/stockpile/index.asp>.

U.S. Department of Justice, Office of Domestic Preparedness, Publications Library, <http://www.ojp.usdoj.gov/odp/library/bulletins.htm>.

U.S. Department of Labor, Occupational Health and Safety Administration, Washington, DC:

Title 29, Code of Federal Regulations, Part 1910:

*Employee Protection Plans*, 1910.38

*Hazardous Materials*

Subpart H – *Hazardous Materials* (1910.101-126), specifically 1910.120 – *Hazardous Waste Operations and Emergency Response* (HAZWOPER) and Appendices A-E.

Subpart I – *Personal Protective Equipment* (1910.132-139 and Appendix B), specifically:

1910.132, *General Provisions*

1910.133, *Eye and Face Protection*

1910.134, *Respiratory Protection* (and appendices A-D)

1910.136, *Occupational Foot Protection*

1910.138, *Hand Protection*

Subpart Z - *Toxic and Hazardous Substances* (1910.1000-1450 and Appendix B), specifically 1910.1200–*Hazard Communication* (and Appendices A-E).

Publication 3114, *Hazardous Waste Operations and Emergency Response*, <http://www.osha.gov/Publications/OSHA3114/osha3114.html>.

Publication 3152, *Hospitals and Community Emergency Response—What You Need to Know*, <http://www.osha.gov/Publications/OSHA3152/osha3152.html>.

U.S. Department of Veterans Affairs, Veterans Health Administration, <http://www.va.gov/emshg/emp/emp.htm>, *Emergency Management Program Guidebook*, Health Care Facility.

**D.1.2.14 Other Publications.** *DuPont Safety News*, June 14, 1965.

Dasler and Bauer, *Ind. Eng. Chem. Anal.*, Ed. 18, 52 (1964).

Hoeltge, G. A., Miller, A., Klein, B. R., Hamlin, W. B., *Accidental fires in clinical laboratories*.

ISO/IEC 31010, *Risk Management — Risk Assessment Techniques*, 2009.

SEMI S10-0307E, *Safety Guideline for Risk Assessment and Risk Evaluation Process*.

**D.2 Informational References.** The following documents or portions thereof are listed here as informational resources only. They are not a part of the requirements of this document.

**D.2.1 Published Articles on Fire Involving Respiratory Therapy Equipment and Related Incidents.** Benson, D. M., and Wecht, C. H. Conflagration in an ambulance oxygen system. *Journal of Trauma*, vol. 15, no. 6:536-649, 1975.

Dillon, J. J. Cry fire! *Respiratory Care*, vol. 21, no. 11:1139-1140, 1976.

Gjerde, G. E., and Kraemer, R. An oxygen therapy fire. *Respiratory Care*, vol. 25, no. 3 3:362-363, 1980.

Walter, C. W. Fire in an oxygen-powered respirator. *JAMA* 197:44-46, 1960.

Webre, D. E., Leon, R., and Larson, N.W. Case History; Fire in a nebulizer. *Anesthesia and Analgesia* 52:843-848, 1973.

**D.2.2 References for A.10.2.13.4.3.** Dalziel, C. F., and Lee, W. R., Reevaluation of lethal, electric currents effects of electricity on man. *Transactions on Industry and General Applications*, vol. IGA-4, no. 5, September/October 1968.

Roy, O. A., Park, G. R., and Scott, J. R., Intracardiac catheter fibrillation thresholds as a function of duration of 60 Hz current and electrode area. *IEEE Trans. Biomed. Eng.* BME 24:430-435, 1977.

Roy, O. A., and Scott, J. R., 60 Hz ventricular fibrillation and pump failure thresholds versus electrode area. *IEEE Trans. Biomed. Eng.* BME 23:45-48, 1976.

Watson, A. B., Wright, J. S., and Loughman, J., Electrical thresholds for ventricular fibrillation in man. *Med. J. Australia* 1:1179-1181, 1973.

Weinberg, D. I., et al., Electric shock hazards in cardiac catheterization. *Elec. Eng.* 82:30-35, 1963.

**D.2.3 Addresses of Other Organizations that Publish Standards or Guidelines.** American Conference of Governmental Industrial Hygienists, 1330 Kemper Meadow Drive, Cincinnati, OH 45240-1634.

American Industrial Hygiene Assoc., 475 Wolf Ledges Parkway, Akron, OH 44311.

College of American Pathologists, 325 Waukegan Road, Northfield, IL 60003.

George Washington University, School of Engineering and Applied Sciences, Institute for Crisis, Disaster and Risk Management. *Medical and Health Incident Management (maHim) System: A Comprehensive Functional System Description for Mass Casualty Medical and Health Incident Management*, <http://www.seas.gwu.edu/~icdm/MaHIM%20V2%20final%20report%20sec%202.pdf>.

National Emergency Management Association, Council of State Governments, Lexington, KY, Emergency Management Assistance Compact, <http://www.emacweb.org/emac/index.cfm?CFID=5327&CFTOKEN=28115803>.

Scientific Apparatus Makers Assoc., 1101 16th Street, NW, Washington, DC 20036.

University of Colorado, Natural Hazards and Information Applications Center, Disaster Research Clearinghouse, [www.colorado.edu/hazards](http://www.colorado.edu/hazards).

University of Delaware, Disaster Research Center, <http://www.udel.edu/DRC/>.

#### **D.2.4 Addresses of Organizations and Agencies That Provide Health Care Emergency Preparedness Educational Materials.**

**D.2.4.1 Publications.** National Fire Protection Association, 1 Batterymarch Park, Quincy, MA 02169-7471.

American Health Care Association, 1201 L Street, Washington, DC 20005.

American Hospital Association, 840 North Lake Shore Drive, Chicago, IL 60611.

American Medical Association, 515 N. State Street, Chicago, IL 60610.

American Red Cross, National Headquarters, 2025 E Street, NW, Washington, DC 20006.

American Nurses' Association, 8515 Georgia Avenue, Suite 400, Silver Spring, MD 20910.

American Red Cross:

Family Disaster Planning <http://www.redcross.org/services/disaster/beprepared/familyplan.html> Disaster Preparedness for People with Disabilities <http://www.redcross.org/services/disaster/beprepared/disability.html>

Association of American Railroads, 50 F Street, Washington, DC 20001-1564.

Charles C. Thomas Publisher, 2600 South First Street, Springfield, IL 62704.

Dun-Donnelley Publishing Corp., 666 Fifth Avenue, New York, NY 10019.

Federal Emergency Management Agency, 500 C Street, SW, Washington, DC 20472.

Florida Health Care Association, 307 W. Park Avenue, P.O. Box 1459, Tallahassee, FL 32301.

Helicopter Association International, 1635 Prince Street, Alexandria, VA 22314-2818.

Hospital Emergency Incident Command System, State of California Emergency Medical Services Authority, 1930 9th Street, Sacramento, CA 95814. <http://www.emsa.ca.gov/dms2/heics3.htm>

International Association of Fire Chiefs, 4025 Fair Ridge Drive, Suite 300, Fairfax, VA 22033-2868.

Joint Commission on Accreditation of Healthcare Organizations (JCAHO), One Renaissance Blvd., Oakbrook Terrace, IL 60181.

National Interagency Incident Management System, Incident Command System, National Interagency Fire Coordination Center, Boise, ID. [http://www.nwccg.gov/pms/forms/ics\\_cours/ics\\_courses.htm](http://www.nwccg.gov/pms/forms/ics_cours/ics_courses.htm)

Pan American Health Organization, 525 23rd Street, NW, Washington, DC 20037 (Attn.: Editor, Disaster Preparedness in the Americas).

Standardized Emergency Management System, State of California Governor's Office of Emergency Services, 3650 Schreiber Avenue, Mather, CA 95655. <http://www.oes.ca.gov/Operational/OESHome.nsf/Content/B49435352108954488256C2A0071E038?OpenDocument>

University of Delaware, Disaster Research Center (Publications), Newark, DE 19716.

U.S. Department of Transportation (available from U.S. Government Printing Office, Washington, DC 20402).

**D.2.4.2 Audio-Visual Materials.** National Fire Protection Association, 1 Batterymarch Park, Quincy, MA 02169-7471.

Abbott Laboratories, Audio/Visual Services, 565 Fifth Avenue, New York, NY 10017.

Brose Productions, Inc., 10850 Riverside Drive, N. Hollywood, CA 91602.

Federal Emergency Management Agency, Office of Public Affairs, Washington, DC 20472.

Fire Prevention Through Films, Inc., P.O. Box 11, Newton Highlands, MA 02161.

General Services Administration, National Audiovisual Center, Reference Section, Washington, DC 20409.

Helicopter Association International, 1635 Prince Street, Alexandria, VA 22314-2818.

Pyramid, P.O. Box 1048, Santa Monica, CA 90406.

University of Illinois Medical Center, Circle Campus, Chicago, IL 60612.

#### **D.3 References for Extracts in Informational Sections.**

NFPA 30, *Flammable and Combustible Liquids Code*, 2012 edition.

NFPA 110, *Standard for Emergency and Standby Power Systems*, 2010 edition.

NFPA 704, *Standard System for the Identification of the Hazards of Materials for Emergency Response*, 2012 edition.

Index

Copyright © 2011 National Fire Protection Association. All Rights Reserved.

The copyright in this index is separate and distinct from the copyright in the document that it indexes. The licensing provisions set forth for the document are not applicable to this index. This index may not be reproduced in whole or in part by any means without the express written permission of NFPA.

-A-

**Absolute atmosphere (ATA) (definition)** ..... 3.3.14.2  
**Absolute pressure (definition)** ..... 3.3.147.1  
**Access** ..... 13.5, A.13.5.3.1  
**ACFM (actual cubic feet per minute) (definition)** ..... 3.3.1  
**Active electrode (definition)** ..... 3.3.43.1  
**Adapters** ..... 10.2.4, 10.5.2.3  
**Adiabatic heating (definition)** ..... 3.3.2  
**Aerosols** ..... 11.5.1.2.1, 15.13.3.1  
 Definition ..... 3.3.3  
**Aftercoolers** ..... 5.1.3.6.3.5, 5.1.3.6.3.10(C), 5.1.3.6.3.10(H), 5.2.3.5(1)  
**Air**  
 Compressors ..... *see also* Compressed air systems (Category 3); Medical air compressors  
 Compressed air starting devices ..... 6.4.1.1.14  
 Hyperbaric chambers ..... 14.2.4.2, A.14.2.4.2.1  
 Medical ..... *see* Medical air  
 Monitoring, hyperbaric chamber ..... 14.2.8.6, A.14.2.8.6  
 Nonmedical compressed air ..... 8.3.5  
 Definition ..... 8.1.4.1  
**Air conditioning** ..... *see* Heating, ventilating, and air conditioning (HVAC) systems  
**Alarm systems** ..... 15.7, A.15.7.1 to A.15.7.4.3.2; *see also* Nurse call systems  
 Annunciator, remote ..... 6.4.1.1.17, A.6.4.1.1.17.1  
 Area ..... 5.1.8.1.6, 5.1.9.1, 5.1.9.3, 5.1.12.3.5.3, 5.1.13.7.3, A.5.1.9.3.1 to A.5.1.9.3.4(2)  
 Definition ..... 3.3.4.1  
 Category 1 ..... 5.1.3.5.8, 5.1.9, 5.1.14.2.3.1(9), 5.1.14.2.3.1(10), A.5.1.9, A.5.1.14.2.3.1(9), B.5.2.9 to B.5.2.13, B.5.2.15, B.5.2.16 *see also subheads:* Area, Local, Master  
 Bulk systems ..... 5.1.3.5.12.4, A.5.1.3.5.12.4  
 Instrument air ..... 5.1.3.9.10  
 Labeling ..... 5.1.11.4  
 Medical air compressors ..... *see* Medical air compressors  
 Medical-surgical vacuum system ..... 5.1.3.7.4, 5.1.3.7.8  
 Proportioning system for medical air ..... 5.1.3.6.3.15(C)(9), A.5.1.3.6.3.15(C)(9)  
 Support gases ..... 5.1.13.7  
 Tests ..... 5.1.12.3.5, 5.1.14.4.8  
 Waste anesthetic gas disposal (WAGD) ..... *see* Waste anesthetic gas disposal (WAGD) systems  
 Category 2 ..... 5.2.9  
 Category 3 ..... 5.3.6.22  
 Definition ..... 3.3.4.2  
 Tests ..... 5.3.6.23.3.6, 5.3.13.4.2, 5.3.13.4.5  
 Changeover signals ..... 5.1.9.2.4, B.5.2.10 to B.5.2.13  
 Essential electrical systems ..... 6.4.2.2.3.2(7), 6.5.2.2.2.1(3), 7.3.1.2.2.7(B)  
 Generator sets ..... 6.4.1.1.16.1  
 Hyperbaric chambers ..... 14.2.1.4.4.5, 14.2.5.1.4, 14.2.5.4, 14.2.6.2, 14.2.7.3.16, A.14.2.5.1.4, A.14.2.5.4.2, A.14.2.7.3.16.1  
 Labeling ..... 5.1.11.4  
 Local ..... 5.1.3.5.8, 5.1.3.6.3.9, 5.1.3.6.3.13, 5.1.3.7.4, 5.1.9.1, 5.1.9.5, 5.1.13.7.4, A.5.1.3.6.3.9, A.5.1.9.5 *see also* Local signal  
 Definition ..... 3.3.4.3

Master ..... 5.1.3.5.12.4, 5.1.3.6.3.15(C)(9), 5.1.8.1.6, 5.1.9.1, 5.1.9.2, 5.1.12.3.5.2, 5.1.13.7.2, A.5.1.3.5.3.15(C)(9), A.5.1.3.5.12.4, A.5.1.9.2, B.5.2.10 to B.5.2.13  
 Computer systems as substitutes for ..... 5.1.9.4  
 Definition ..... 3.3.4.4  
 Occupant notification ..... 15.7.4, A.15.7.4.2.1 to A.15.7.4.3.2  
 Remote control ..... 6.4.1.1.17, A.6.4.1.1.17.1  
 Signal initiation ..... 15.7.2, A.15.7.2.4  
 Silencing means ..... 6.4.1.1.17.2, 6.4.1.1.17.3  
**Alternate power sources** ..... 6.4.1.1.4 to 6.4.1.1.6, 6.4.2.2.2, 6.6.3.1.1; *see also* Generator sets  
 Connection to ..... 6.4.2.2.5.2  
 Definition ..... 3.3.5  
 Maintenance and testing of ..... 6.4.4.1.1, 6.5.4.1.1, 6.6.4.1.1, A.6.4.4.1.1.4(A)  
 Transfer to ..... *see* Transfer switches  
**Ambient atmosphere (definition)** ..... 3.3.14.1  
**Ambient pressure (definition)** ..... 3.3.147.2  
**Ambulatory health care centers (definition)** ..... 3.3.6  
**Ampacity (definition)** ..... 3.3.7  
**Anesthetic apparatus** ..... 11.4.1, A.11.4.1.1 to A.11.4.1.4  
**Anesthetics** ..... *see also specific gases*  
 Definition ..... 3.3.8  
 Flammable ..... 5.1.14.1.1, A.5.1.14.1.1  
 Nonflammable anesthetic agent (definition) ..... 3.3.125, A.3.3.125  
 Waste ..... *see* Waste anesthetic gas disposal (WAGD) systems  
**Anesthetizing locations** ..... 1.3.4.2; *see also* Waste anesthetic gas disposal (WAGD) systems  
 Definition ..... 3.3.9, A.3.3.9  
**Animal chambers** ..... 14.1.2.2(3), 14.2.2.3  
**Anoxia (definition)** ..... 3.3.10  
**Antiseptics** ..... 15.13.3, A.15.3.3.2  
**Apparatus** ..... *see* Anesthetic apparatus; Equipment  
**Appliances** ..... *see also* Electrical equipment; Equipment  
 Battery-powered ..... 14.2.7.3.17.5  
 Definition ..... 3.3.11  
 Double-insulated ..... 10.2.2.1.2, 10.4.2.3  
 Definition ..... 3.3.41, A.3.3.41  
**Application of standard** ..... 1.3  
**Applicator (definition)** ..... 3.3.12, A.3.3.12  
**Approved (definition)** ..... 3.2.1, A.3.2.1  
**Area of administration (definition)** ..... 3.3.13  
**Atmosphere**  
 Absolute (ATA) (definition) ..... 3.3.14.2  
 Ambient (definition) ..... 3.3.14.1  
 Chamber (definition) ..... 3.3.14.4  
 Definition ..... 3.3.14, A.3.3.14  
 Of increased burning rate (definition) ..... 3.3.14.3, A.3.3.14.3  
 Oxygen-enriched ..... *see* Oxygen-enriched atmosphere  
**Attachment plugs** ..... *see* Plugs (attachment plugs, caps)  
**Authority having jurisdiction**  
 Definition ..... 3.2.2, A.3.2.2  
 Emergency planning responsibilities ..... 12.2.1, A.12.2.1  
**Automatic (definition)** ..... 3.3.15  
**Automatic sprinklers** ..... *see* Sprinklers, automatic

-B-

**Basic care rooms** ..... *see* Patient care rooms  
**Bathrooms**  
 Definition ..... 3.3.16  
 Electrical receptacles ..... 6.3.2.2.6.2(D)



Nurse call systems ..... 7.3.3.1.6.1, 7.3.3.1.6.3, 7.3.3.1.7.1, 7.4.3.1.5.1, 7.4.3.1.5.3, 7.4.3.1.6.1

Wet procedure locations ..... 6.3.2.2.8.3

**Batteries** ..... 6.4.1.2

  Cranking ..... 6.4.1.1.13

  Maintenance ..... 6.4.4.1.3, 6.5.4.1.3, 6.6.4.1.3

  Performance criteria and tests ..... 6.6.3.3.1

  Type 3 systems ..... 6.6.1.2, 6.6.3.3.1

**Battery-powered lighting units** ..... 6.3.2.2.11

  Definition ..... 3.3.17

**Battery systems, fire extinguishing** ..... 14.2.5.4.3

**Bends (definition)** ..... 3.3.18

**Bilge, hyperbaric facilities** ..... 14.2.2.4.3

**Branch circuits**

  Definition ..... 3.3.19

  Patient care rooms ..... 6.3.2.2.1.1, A.6.3.2.2.1.1

  Special-purpose outlets, serving ..... 6.3.2.2.1.4

**Branch (lateral) lines, piping** ..... 5.1.10.3.2

  Definition ..... 3.3.144.1

**Brazing** ..... 5.1.6.8, 5.1.10.3.1(1), 5.1.10.4, 5.1.10.11.11, 5.3.6.2.3, 5.3.6.2.4, 5.3.6.3 to 5.3.6.10, 5.3.7.2.2, 5.3.7.2.3.1, 5.3.7.2.3.2, A.5.1.10.4.5, A.5.3.6.8

**Breathing apparatus, hyperbaric chambers** ..... 14.2.4.1.3, 14.2.4.5.3, A.14.2.4.5.3

**Building system categories** ..... 4.1, A.4.1

  Application ..... 4.3

  Category 1 ..... 4.1.1, A.4.1(1)

  Category 2 ..... 4.1.2, A.4.1(2)

  Category 3 ..... 4.1.3, A.4.1(3)

  Category 4 ..... 4.1.4, A.4.1(4)

  Plumbing system ..... 8.2, A.8.2

  Risk assessment procedure, determination using ..... 4.2, A.4.2

**Bulk systems** ..... 5.1.3.6.1(1)

  Cryogenic liquids ..... *see* Cryogenic liquids

  Definition ..... 3.3.21

  Inert gas ..... 5.1.3.3.1.13, A.5.1.3.3.1.13

    Definition ..... 3.3.21.1

  Nitrous oxide (definition) ..... 3.3.21.2

  Oxygen (definition) ..... 3.3.21.3, A.3.3.21.3

**Bypass-isolation switch** ..... 6.4.2.1.8, A.6.4.2.1.8.3

-C-

**Cannula, nasal (definition)** ..... 3.3.114

**Carbon dioxide**

  Designation colors/operating pressures ..... Table 5.1.11

  Monitoring ..... 14.2.8.5

  Supply systems ..... 5.1.1.2, 5.1.3.3.1.8, 5.1.3.3.1.11, 5.1.3.3.1.12, 5.1.3.5.2, A.5.1.1.2; *see also* Medical gas systems

**Carbon monoxide monitors** ..... 5.1.13.4.7(2)

**Cardiac defibrillators** ..... *see* Defibrillators

**Carts, for cylinders** ..... 11.4.3.1

**Casters** ..... 11.4.2.1, 14.3.6.2.1.2, 14.3.6.2.1.3, A.14.3.6.2.1.2

**Category 3 compressed air systems** ..... *see* Compressed air systems (Category 3)

**Category 3 drive gas systems** ..... 5.3.1.3, 5.3.7, 5.3.9, 5.3.11.3, 5.3.12, A.5.3.7, A.5.3.12

  Definition ..... 3.3.22

  General requirements ..... 5.3.7.1, A.5.3.7.1.3

  Maintenance ..... 5.3.13.4.4(2)

  Piping ..... 5.3.7.2 to 5.3.7.4, 5.3.12.2.2

  Source equipment

    Air compressor source ..... 5.3.7.5, 5.3.7.6, A.5.3.7.6.3, 5.3.7.6.5

    Compressed air cylinder ..... 5.3.7.7

  Tests ..... 5.3.9, 5.3.12.1

**Category 1 emergency management requirements** ..... 12.5, A.12.5.3.1.2 to A.12.5.3.5

**Category 2 emergency management requirements** ..... 12.5, A.12.5.3.1.2 to A.12.5.3.5

**Category 1 information technology and communications systems** ..... 7.3, A.7.3.1.2

  Infrastructure ..... 7.3.1, A.7.3.1.2

  Cabling pathways and raceway requirements ..... 7.3.1.2.4

  Entrance facility (EF) ..... 7.3.1.2.1, A.7.3.1.2.1.3(B) to A.7.3.1.2.1.6(C)

  Premises distribution system (fiber and copper) ..... 7.3.1.1

  Remote primary data center ..... 7.3.1.2.1.3, A.7.3.1.2.1.3(B)

  Telecommunications equipment room (TER) ..... 7.3.1.2.1.1, 7.3.1.2.1.6, 7.3.1.2.2, A.7.3.1.2.1.6(C), A.7.3.1.2.2.2

  Telecommunications room (TR) ..... 7.3.1.2.3

  Telecommunications systems spaces and pathways ..... 7.3.1.2, A.7.3.1.2

  Nurse call systems ..... 7.3.3.1

**Category 2 information technology and communications systems** ..... 7.4

  Infrastructure ..... 7.4.1

  Nurse call systems ..... 7.4.3.1

**Category 3 information technology and communications systems** ..... 7.5

**Category 1 piped gas and vacuum systems** ..... 5.1, A.5.1.1 to A.5.1.15; *see also* Medical-surgical vacuum systems; Waste anesthetic gas disposal (WAGD) systems

  Alarms ..... *see* Alarm systems

  Applicability of requirements ..... 5.1.1, A.5.1.1

  Cross-connections ..... 5.1.12.2.4, 5.1.12.3.3, B.5.1

  Designation colors/operating pressures ..... Table 5.1.11

  Distribution ..... 5.1.10, 5.1.14.8, A.5.1.10.1.4 to A.5.1.10.8(3)

  Hazards, nature of ..... 5.1.2, 5.1.13.1, A.5.1.13.1

  Labeling and identification ..... 5.1.11, 5.1.12.3.13, 5.1.14.2.3.1(5), 5.1.14.2.3.1(8), 5.1.14.3, 5.1.14.9, A.5.1.11

  Maintenance ..... 5.1.14.2, 5.1.14.4, 5.1.15, A.5.1.14.2.1 to A.5.1.14.2.3.1(11), A.5.1.15, B.5.2

  Manufactured assemblies ..... *see* Manufactured assemblies

  Operation and management ..... 5.1.14, A.5.1.14

  Performance criteria and tests ..... 5.1.6.1(4), 5.1.6.2, 5.1.12, 5.1.13.10, A.5.1.12, B.5.1

  Pressure and vacuum indicators ..... 5.1.8, 5.1.14.6, A.5.1.8.1.3, B.5.2.5, B.5.2.14

  Sources ..... 5.1.3, A.5.1.3, B.5.2.1 to B.5.2.4 *see also* Central supply systems

    Inspection and testing ..... 5.1.14.2.3.1(1), A.5.1.14.2.3.1(1)

    Instrument air supply systems ..... *see* Instrument air, supply systems

    Medical air supply systems ..... 5.1.3.6, A.5.1.3.6, B.5.2.6 to B.5.2.8

    Medical-surgical vacuum supply systems ..... 5.1.3.5(5), 5.1.3.7, 5.1.12.3.14.5, A.5.1.3.7

    Reserve supply ..... *see* Reserve supply

    Support gases ..... 5.1.13.2

    Verification of equipment ..... 5.1.12.3.14, 5.1.14.4.6

    Waste anesthetic gas disposal (WAGD) ..... 5.1.3.8, A.5.1.3.8

  Station inlets ..... *see* Station inlets

  Station outlets ..... *see* Station outlets

  Support gases ..... 5.1.13, 5.1.14.2, A.5.1.13.1, A.5.1.14.2.1 to A.5.1.14.2.3.1(11)

    Breaching or penetrating of medical gas piping ..... 5.1.10.11.12.1

    Central supply system for ..... 5.1.3.5.3

    Joints ..... 5.1.10.3.1, A.5.1.10.3.1

    Surface-mounted medical gas rails ..... 5.1.7, A.5.1.7

  Tests

    Maintenance program ..... 5.1.14.2.3, 5.1.14.4.1, 5.1.14.4.5 to 5.1.14.4.7, A.5.1.14.2.3.1(1) to A.5.1.14.2.3.1(11), B.5.2

    Performance ..... *see* Performance criteria and tests

    Retests ..... B.5.2

  Valves ..... *see* Valves

**Category 2 piped gas and vacuum systems** ..... 5.2, A.5.2.1, A.5.2.14; *see also* Central supply systems

  Alarms ..... 5.2.9

  Applicability of requirements ..... 5.2.1, A.5.2.1

Distribution .....	5.2.10	Components .....	5.1.3.5, A.5.1.3.5, B.5.2.1 to B.5.2.4
Hazards, nature of .....	5.2.2	Control equipment .....	5.1.3.4
Labeling and identification .....	5.2.3.1, 5.2.11	Headers .....	5.1.3.5.9, A.5.1.3.5.9
Maintenance .....	5.2.14, A.5.2.14	Labeling and identification .....	5.1.3.1, A.5.1.3.1.1
Manufactured assemblies .....	5.2.6	Locations .....	5.1.3.3, A.5.1.3.3
Operation and management .....	5.2.3.2, 5.2.13	Operations .....	5.1.3.2
Performance criteria and tests .....	5.2.12	Reserve supply .....	<i>see</i> Reserve supply
Pressure and vacuum indicators .....	5.2.8	Category 2 .....	5.2.3.1 to 5.2.3.4
Sources .....	5.2.3	Labeling and identification .....	5.2.3.1
Station outlets/inlets .....	5.2.5	Locations .....	5.2.3.3
Surface-mounted medical gas rails .....	5.2.7	Operations .....	5.2.3.2
Valves .....	5.2.4	Category 3 .....	5.3.6.21.8
<b>Category 3 piped gas and vacuum systems</b> .....	5.3, A.5.3; <i>see also</i>	Hyperbaric oxygen systems .....	14.2.1.4.4.2, 14.2.1.4.4.4, 14.2.1.4.4.7
Category 3 drive gas systems; Category 3 vacuum systems; Compressed air systems (Category 3); Scavenging		<b>Chamber atmosphere (definition)</b> .....	3.3.14.4
Alarms .....	<i>see</i> Alarm systems	<b>Chemicals, hazardous (definition)</b> .....	3.3.70, A.3.3.70
Applicability of .....	5.3.1, A.5.3.1	<b>Chutes, rubbish/laundry</b> .....	15.6
Central supply systems .....	5.3.6.21.8	<b>Circuit breakers</b> .....	6.4.4.1.2.1, A.6.4.4.1.2.1
Central-connections		<b>Circuits</b>	
Protection against .....	5.3.4, 5.3.6.18.4	Branch .....	<i>see</i> Branch circuits
Tests and inspections .....	5.3.6.23.2.1(D), 5.3.6.23.2.4, 5.3.6.23.3.4, 5.3.6.23.3.5, 5.3.9.2.5, 5.3.9.2.6	Maintenance and testing of .....	6.4.4.1.2, 6.5.4.1.2, 6.6.4.1.2, A.6.4.4.1.2.1
Distribution .....	5.3.6.2, 5.3.6.21.9, 5.3.7.8.3, 5.3.9.3.7.2, 5.3.12.2.1	Patient care rooms .....	6.3.2.2, A.6.3.2.2.1 to A.6.3.2.2.8.7
Gas-powered devices .....	<i>see</i> Category 3 drive gas systems	Restoration of .....	6.4.1.1.1.2(2)
Hazards, nature of .....	5.3.2	Telecommunications facility .....	7.3.1.2.2.7, 7.3.1.2.3.8
Labeling and identification .....	5.3.6.23.3.13, 5.3.9.2.5.8, 5.3.9.2.6.7, 5.3.10.2, 5.3.10.4, 5.3.11, 5.3.13.3	<b>Cleaning, hyperbaric facilities</b> .....	14.3.6.4, A.14.3.6.4
Maintenance .....	5.3.13.4	<b>Clinical support activities, emergency plan for</b> .....	12.5.3.3.6.4
Manufactured assemblies .....	5.3.6.23.2.1(C), 5.3.9.2.1.4	<b>Closets, sprinklers in</b> .....	15.8.1.3, A.15.8.1.3
Nonstandard operating pressures, systems with .....	5.3.5	<b>Clothing in hyperbaric chambers</b> .....	14.3.1.5.5.1
Operations and management .....	5.3.13	<b>Code (definition)</b> .....	3.2.3, A.3.2.3
Performance criteria and tests .....	5.3.6.23, 5.3.9, A.5.3.6.23.2.3(E) to 5.3.6.23.3.11	<b>Cold room (definition)</b> .....	3.3.24; <i>see also</i> Refrigerating equipment
Pressure and moisture indicators .....	5.3.7.6.1(16), 5.3.7.6.1(17), 5.3.7.6.3, A.5.3.7.6.3	<b>Combustible (definition)</b> .....	3.3.25
Scavenging systems .....	<i>see</i> Scavenging	<b>Combustible liquids</b>	
Seismic restraint .....	5.3.3	Definition .....	3.3.26, A.3.3.26
Service outlets/inlets .....	5.3.9.2.5.8, 5.3.9.2.6.5, 5.3.9.2.6.7, A.5.3, A.5.3.6.17, A.5.3.7, A.5.3.8.3.9	In hyperbaric chambers .....	14.3.1.5.2, A.14.3.1.5.2.2(2)
Sources		Use of .....	11.5.1.2.3
Drive gas systems .....	<i>see</i> Category 3 drive gas systems	<b>Combustion (definition)</b> .....	3.3.27, A.3.3.27
Medical gas supply systems .....	<i>see</i> Medical gas supply systems, Category 3	<b>Communications</b> .....	<i>see</i> Information technology and communications systems
Reserve supply .....	5.1.9.2.4, B.5.2.10 to B.5.2.13	<b>Compact storage</b>	
Vacuum systems .....	5.3.8.3.9, 5.3.9.3.7, 5.3.13.4.4(3)	Definition .....	3.3.28
Verification of equipment .....	5.3.6.23.3.2, 5.3.13.4.3	Fire protection .....	15.10, 15.11, A.15.10, A.15.11.3
Special precautions .....	5.3.13.2	Mobile .....	15.11, A.15.11.3
Station outlets/inlets .....	5.3.6.23.3.10(A), 5.3.9.2.5.8, 5.3.9.2.6.5, 5.3.9.2.6.7	<b>Compartmentation of facility</b> .....	15.2
System use .....	5.3.12, A.5.3.12	<b>Compressed air starting devices</b> .....	6.4.1.1.14
Tests		<b>Compressed air systems (Category 3)</b> .....	5.3.7.6, A.5.3.7.6.3, A.5.3.7.6.5; <i>see also</i> Instrument air; Medical air compressors
Maintenance program .....	5.3.13.4	Air source .....	5.3.7.6.5, A.5.3.7.6.5
Performance .....	5.3.6.23, 5.3.9, A.5.3.6.23.2.3(E) to 5.3.6.23.3.11	Cylinder source equipment .....	5.3.7.7
Prohibited interconnections for .....	5.3.12.1	Location .....	5.3.6.20.5, 5.3.7.5
Valves .....	<i>see</i> Valves	Nitrogen source equipment .....	5.3.7.8, A.5.3.7.8
<b>Category 3 vacuum systems</b> .....	5.3.1.4, 5.3.8, 5.3.11.3, 5.3.12, A.5.3.8.3.9 to A.5.3.8.3.11(8), A.5.3.12	<b>Conductive accessories</b> .....	14.3.6.2.2
Definition .....	3.3.23	<b>Conductive surfaces, exposed</b>	
Drains .....	5.3.8.3.10	Definition .....	3.3.50
Exhaust .....	5.3.8.3.11	Tests .....	6.3.3.1.1.2, 6.3.3.1.1.3
General requirements .....	5.3.8.1	<b>Conductors</b>	
Maintenance .....	5.3.13.4	Isolated ungrounded systems .....	6.3.2.6.4
Performance criteria and tests .....	5.3.9	Isolation of neutral .....	6.4.2.1.5.14, A.6.4.2.1.5.14
Piping .....	5.3.8.2, 5.3.8.3, 5.3.12.2.2, 5.3.13.2, 5.3.13.4.4(4), A.5.3.8.3.9 to A.5.3.8.3.11(8)	<b>Connections</b>	
Source equipment .....	5.3.8.3.9, 5.3.9.3.7, 5.3.13.4.4(3)	Exterior .....	12.5.3.3.6.6
Tests .....	5.3.9, 5.3.12.1	Future, valves for .....	5.1.4.10
<b>Catheter, nasal (definition)</b> .....	3.3.115	<b>Connectors, flexible</b> .....	<i>see</i> Flexible connectors
<b>Central supply systems</b>		<b>Construction</b>	
Category 1		Central supply systems and storage .....	5.1.3.3.2, A.5.1.3.3.2
		Health care facility .....	15.2
		Hyperbaric facilities .....	14.2, A.14.2.1.1.1 to A.14.2.9.2
		<b>Containers</b> .....	5.3.10; <i>see also</i> Cylinders
		Connections .....	11.6.3
		Definition .....	3.3.29
		Handling .....	5.1.3.2.2, 11.4.2.3
		Labeling .....	5.1.3.1, 5.3.10.2, 5.3.10.4, A.5.1.3.1.1

Liquid oxygen ambulatory (definition) ..... 3.3.29.1  
 Liquid oxygen base reservoir ..... 11.7, A.11.7.3.1 to A.11.7.3.5.1.1  
     Definition ..... 3.3.29.2  
 Liquid oxygen home care (definition) ..... 3.3.29.3  
 Liquid oxygen portable container ..... 11.7, A.11.7.3.1 to A.11.7.3.5.1.1  
     Definition ..... 3.3.29.4  
 Safety mechanisms ..... 11.6.4  
 Source ..... 11.2, A.11.2.8  
 Storage ..... 11.3, 11.5.2, 11.6.5, A.11.3.1, A.11.3.2, A.11.5.2.1.1  
**Controls**  
     Central supply system ..... 5.1.3.4  
     Electrical equipment ..... 14.2.8.1.3(1)  
**Conveyors** ..... 15.5.3  
**Cooking equipment** ..... 15.5.2.3  
**Cooling, essential electrical system generator sets** ..... 6.4.1.1.12, A.6.4.1.1.12  
**Cords** ..... *see* Power cords  
**Cover plates** ..... 6.4.2.2.6.2(C), 6.5.2.2.4.2, A.6.4.2.2.6.2(C), A.6.5.2.2.4.2  
**Cranking batteries** ..... 6.4.1.1.13  
**Critical branch** ..... 6.4.1.1.3, 6.4.2.2.1.1(2), 6.4.2.2.4, 6.4.2.2.5.3(B), 6.5.2.2.2, 7.3.1.2.3.8(B), 14.2.5.4.3, 14.2.7.2.2, A.6.4.2.2.4, A.6.5.2.2.2.1(4)  
     Definition ..... 3.3.30  
     Mechanical protection of ..... 6.4.2.2.6.4  
**Critical care rooms** ..... *see* Patient care rooms  
**Critical equipment (definition)** ..... 3.3.32  
**Cross-connections**  
     Protection against ..... 5.3.4, 5.3.6.18.4  
     Tests ..... 5.1.12.2.4, 5.1.12.3.3, 5.3.6.23.2.1(D), 5.3.6.23.2.4, 5.3.6.23.3.4, 5.3.6.23.3.5, 5.3.9.2.5, 5.3.9.2.6, B.5.1  
**Crowd control** ..... 13.7, A.13.7  
**Cryogenic liquids** ..... 5.1.3.1.4 to 5.1.3.1.6, 5.1.3.2.7, 5.1.3.2.8, 5.1.3.3.1.1, 5.1.3.3.1.2(3), 5.1.3.5(2), 5.1.3.5(3)  
     Bulk systems ..... 5.1.3.5.8.1(4), 5.1.3.5.12, 5.1.3.5.13, 5.1.9.2.4, 5.1.14.2.3.1(6), 5.1.14.4.2, 5.1.14.4.3, A.5.1.3.5.12, B.5.2.2, B.5.2.3, B.5.2.4  
     Manifolds, cylinder ..... 5.1.3.5.8.1(3), 5.1.3.5.11, A.5.1.3.5.11  
     Storage or transfilling, ventilation for ..... 9.3.7, A.9.3.7.3, A.9.3.7.5.1  
**Cylinders** ..... 5.3.10  
     Connections ..... 5.3.6.21.2, 5.3.7.7.3 to 5.3.7.7.6, 11.2.2 to 11.2.4, 11.2.9, 11.2.10, 11.6.3  
     Definition ..... 3.3.33  
     Handling ..... 5.1.3.2.2, 5.1.3.2.6 to 5.1.3.2.10, 5.1.3.3.1.7, 5.3.13.1, 11.4.2.3, 11.6  
     Headers ..... 5.1.3.5.8.1(6), 5.1.3.5.9, A.5.1.3.5.9  
     Labeling ..... 5.1.3.1, 5.3.10.2, 5.3.10.4, A.5.1.3.1.1  
     Management ..... 11.6  
     Manifolds for ..... *see* Manifolds  
     Regulators ..... 11.2.5 to 11.2.7  
     Reserves ..... 5.1.9.2.4  
     Safety mechanisms ..... 11.6.4  
     Source ..... 11.2, A.11.2.8  
     Storage ..... 5.1.3.2.3 to 5.1.3.2.5, 5.1.3.2.7, 5.1.3.2.9, 5.1.3.2.11, 5.1.3.3.1.7, 5.1.3.3.4, 5.3.6.20, 5.3.7.5.3, 5.3.7.5.4, 11.3, 11.5.2, 11.6.5, A.11.3.1, A.11.3.2, A.11.5.2.1.1  
     Supply systems ..... 5.1.3.6.1(1), 5.3.6.20, 5.3.6.21.2, 5.3.6.21.10 to 5.3.6.21.14, 5.3.7.7, 5.3.7.8, 14.2.1.6.4.7(2), A.5.3.7.8  
     Transfilling ..... 11.5.2.2, 11.7.3.5, A.11.7.3.5.1.1

**-D-**

**Decompression sickness (definition)** ..... 3.3.34  
**Defend in place** ..... 15.7.4.3, 15.8.1.2, A.15.7.4.3.1, A.15.7.4.3.2, A.15.8.1.2  
     Definition ..... 3.3.35, A.3.3.35  
**Defibrillators** ..... 10.5.2.4, 10.5.4.6, A.10.5.4.6  
**Definitions** ..... Chap. 3

**Delayed-automatic connection, equipment for** ..... 6.4.2.2.5.3, 6.4.2.2.5.4, 6.5.2.2.3.3, 6.5.2.2.3.4, A.6.4.2.2.5.3, A.6.4.2.2.5.4, A.6.5.2.2.3.4  
**Deluge systems** ..... 14.2.5.2, A.14.2.5.2.4, A.14.2.5.2.6  
**Demand check (definition)** ..... 3.3.36  
**Dental office (definition)** ..... 3.3.106, A.3.3.106  
**Detonation (definition)** ..... 3.3.37  
**Direct electrical pathway to heart**  
     Definition ..... 3.3.38, A.3.3.38  
     Protection of patients ..... 10.5.2.2  
**Disasters (definition)** ..... 3.3.39, A.3.3.39; *see also* Emergency management  
**Dispersive electrode (definition)** ..... 3.3.43.3, A.3.3.43.3  
**D.I.S.S. connectors** ..... 5.1.13.2.3.2(D)  
     Definition ..... 3.3.40  
**Distribution piping** ..... 5.1.14.8  
**Documentation**  
     Electrical equipment, records of ..... 10.5.6, A.10.5.6.2  
     Test records ..... *see* Tests  
**Double-insulated appliances** ..... 10.2.2.1.2, 10.4.2.3  
     Definition ..... 3.3.41, A.3.3.41  
**Drains**  
     Category 3 vacuum or scavenging equipment ..... 5.3.8.1.3, 5.3.8.3.10, 5.3.8.10, A.5.3.8.3.10.4  
     Hyperbaric chamber wiring enclosures ..... 14.2.7.3.8  
**Drills**  
     Fire ..... 14.2.4.5.4, 14.3.1.4.5, 15.13.3.10.3, A.14.3.1.4.5  
     Security management ..... 13.11.1, 13.11.2, A.13.11.1

**-E-**

**Egress** ..... 13.5, A.13.5.3.1  
**Electrical equipment** ..... Chap. 10; *see also* Patient-care-related appliances  
     Administration ..... 10.5, A.10.5.2.5 to A.10.5.8.1  
     Anesthetizing locations ..... 11.5.1.3.2  
     Cord- and plug-connected (portable) ..... 10.2.2, 10.4.2, 14.2.7.3.17.6  
     Fire protection ..... 15.5.1.2  
     Hazards ..... 6.2, A.6.2.1  
     Hyperbaric facilities ..... 14.2.8.1  
     Laboratory ..... 10.5.5, A.10.5.5.1, A.10.5.5.2  
     Life support ..... 6.3.2.5.1  
         Definition ..... 3.3.42  
     Maintenance ..... 10.5.3  
     Manuals for ..... 10.5.3.1, 10.5.6.1  
     Nonpatient ..... 10.4  
     Not supplied by facility ..... 10.5.2.7  
     Performance criteria ..... 10.2, A.10.2.3.2.4 to A.10.2.3.6(5)  
     Permanently connected (fixed) ..... 10.2.1  
     Portable ..... 10.2.2, 10.3, 10.4.2, 14.2.7.3.17, A.10.3.1 to A.10.3.6, A.14.2.7.3.17  
     Qualification and training of personnel ..... 10.5.8, A.10.5.8.1  
     Recordkeeping ..... 10.5.6, A.10.5.6.2  
     Respiratory therapy ..... 11.5.1.3.2  
     System demonstration ..... 10.5.2.5, A.10.5.2.5  
     Testing ..... 10.3, 10.5.2.1.2, A.10.3.1 to A.10.3.6  
**Electrical equipment branch** ..... 6.4.2.2.1.1(3), 6.4.2.2.5, A.6.4.2.2.5.3 to A.6.4.2.2.5.4(9)  
**Electrical hazards** ..... 6.2  
**Electrical receptacles** ..... *see* Receptacles  
**Electrical systems** ..... 1.1.4, Chap. 6; *see also* Essential electrical systems  
     Abnormal currents ..... 6.4.1.1.1.2(1), 6.4.1.1.2  
     Administration of ..... 6.3.4, A.6.3.4  
     Design considerations ..... 6.4.1.1.1, A.6.4.1.1.1  
     Distribution ..... 6.3.2, A.6.3.2.2 to A.6.3.2.6.3.4  
         Ground-fault protection ..... 6.3.2.5  
         Installation ..... 6.3.2.1  
         Isolated power systems ..... *see* Isolated power systems  
     Laboratories ..... 6.3.2.3  
     Patient care rooms ..... 6.3.2.2, A.6.3.2.2.1 to A.6.3.2.2.8.7

Emergency plan .....	12.5.3.3.6.5(1)	Surge capacity of victims .....	12.5.3.4.12
Equipment branch .....	6.4.2.2.1.1(3), 6.4.2.2.5, A.6.4.2.2.5.3 to A.6.4.2.2.5.4(9)	Waste anesthetic gas disposal (WAGD), loss of .....	5.2.3.7(2)
Fire protection .....	15.5.1.2 to 15.5.1.4	<b>Emergency oxygen supply connection (EOSC)</b> .....	5.1.3.5.8.1(5), 5.1.3.5.13, A.5.1.3.5.13, B.5.2.4
Hyperbaric facilities .....	14.2.8.1	Definition .....	3.3.45
Information technology and communications systems .....	7.3.1.2.1.5, 7.3.1.2.2.7, 7.3.1.2.3.8, 7.5.1.1.2	<b>Emergency power system (EPS) room HVAC systems</b> .....	9.3.10, A.9.3.10.3.1
Instrument air supply systems .....	5.1.3.9.11	<b>Emergency procedures</b> .....	<i>see also</i> Emergency management
Isolated power systems .....	<i>see</i> Isolated power systems	Hyperbaric facilities .....	14.3.1.4.3 to 14.3.1.4.6, A.14.3.1.4.5
Laboratories .....	6.3.2.3	Operating room .....	15.13.3.9
Maintenance .....	6.3.4, A.6.3.4	<b>Emergency recovery</b> .....	12.5.3.5, A.12.5.3.5
Medical air systems .....	5.1.3.6.3.11	<b>Emergency response</b> .....	12.5.3.4, A.12.5.3.4.1
Medical-surgical vacuum supply systems .....	5.1.3.7.6	<b>Emergency resuscitation alarm (nurse call system)</b> .....	7.3.3.1.8, 7.3.3.1.9
Patient care rooms .....	6.3.2.2, A.6.3.2.2.1 to A.6.3.2.2.8.7	<b>Emergency systems</b> .....	<i>see</i> Critical branch; Equipment branch; Life safety branch
Grounding systems .....	6.3.3.1, A.6.3.3.1.1 to A.6.3.3.1.4	<b>Employees</b>	
Manuals for appliances .....	10.5.3.1, 10.5.6.1	Emergency roles .....	12.5.3.3.6.7, 12.5.3.3.7
Performance criteria and tests .....	6.3.3, A.6.3.3.1.1 to A.6.3.3.1.4	Gas equipment cylinders and containers, handling of ....	11.5.2.1, A.11.5.2.1.1
Grounding systems in patient care rooms .....	6.3.3.1, A.6.3.3.1.1 to A.6.3.3.1.4	Gas equipment servicing .....	11.5.3.3.5, 11.6.1.2
Isolated power systems .....	6.3.3.3	Hyperbaric chambers .....	14.3.1.3, 14.3.1.5.3, 14.3.1.5.5, A.14.3.1.3.2 to A.14.3.1.3.5, A.14.3.1.5.3
Receptacle testing in patient care rooms .....	6.3.3.2	Medical gas and vacuum system installers .....	5.1.10.11.10, 5.1.10.11.11, 5.1.12.2, 5.3.6.1, 5.3.6.3, 5.3.9.2.1.2, 5.3.9.3.1.2, A.5.1.12.2.3.5 to A.5.1.12.2.7.5, B.5.1
Sources of power .....	6.3.1, 6.5.1, 6.6.1	Medical gas and vacuum system maintenance .....	5.1.14.2.2.5, 5.1.14.4.4
Alternate .....	<i>see</i> Alternate power sources	Operating rooms .....	15.13.3.10
Failure of .....	6.4.3.2.2 to 6.4.3.2.8, 6.5.3.2.2 to 6.5.3.2.7, 6.6.3.2	Security management .....	13.9, A.13.9
Performance criteria and tests .....	6.4.3.1, 6.5.3.1, 6.6.3.1	Training .....	<i>see</i> Training, employee
Transfer to .....	<i>see</i> Transfer switches	<b>Enclosures, gas system</b> .....	5.3.6.20.3, 5.3.7.5.4, 5.3.7.8.1, 11.3.2.1, 11.4.2.2
Type 1 essential electrical systems .....	6.4.1, A.6.4.1.1.1 to A.6.4.1.1.17.1	<b>Endotracheal tube (definition)</b> .....	3.3.177.1, A.3.3.177.1
Tests .....	6.3.3, 6.3.4, A.6.3.3.1.1 to A.6.3.3.1.4, A.6.3.4	<b>Equipment</b> .....	<i>see also</i> Electrical equipment
Waste anesthetic gas disposal (WAGD) systems .....	5.1.3.8.5	Critical (definition) .....	3.3.32
<b>Electrical wiring</b>		Hyperbaric .....	14.2, 14.3.2, A.14.2.1.1.1 to A.14.2.9.2, A.14.3.2.16 to A.14.3.2.6
Essential electrical systems .....	6.4.2.2.6, 6.5.2.2.4, 6.6.2.2.3, A.6.4.2.2.6.1, A.6.5.2.2.4.1, A.6.5.2.2.4.2, A.6.6.2.2.3.2	Portable	
Fire protection .....	15.5.1.2	Electrical .....	<i>see</i> Electrical equipment
Hyperbaric facilities .....	14.2.7.3 to 14.2.7.6, A.14.2.7.3 to A.14.2.7.6.1.1	Patient care gas equipment .....	11.4.1, A.11.4.1.1 to A.11.4.1.4
Isolated power systems .....	6.3.2.6.2, A.6.3.2.6.2.1	Rack or cart .....	11.4.3.1
Low-voltage .....	6.3.2.2.5	<b>Equipment branch</b> .....	6.4.2.2.4, 6.5.2.2.3, 7.3.1.2.2.8(B), A.6.4.2.2.4, A.6.5.2.2.3.4
Patient care rooms .....	6.3.2.2.5	Definition .....	3.3.46
<b>Electrocautery equipment</b> .....	14.3.2.1.2(2), 15.13.3, A.15.3.3.2	<b>Equipment grounding bus (definition)</b> .....	3.3.47
<b>Electrode</b>		<b>Equivalency to standard</b> .....	1.4
Active (definition) .....	3.3.43.1	<b>Escalators</b> .....	15.5.3
Bipolar (definition) .....	3.3.43.2	<b>Essential electrical systems</b>	
Definition .....	3.3.43	Definition .....	3.3.48, A.3.3.48
Dispersive (definition) .....	3.3.43.3, A.3.3.43.3	Information technology and communications systems .....	<i>see</i> Information technology and communications systems
<b>Electrosurgery</b> .....	15.13.3, A.15.3.3.2	Patient care rooms .....	6.3.2.2.10
<b>Elevators</b> .....	15.5.3, A.15.5.3.3	Sources .....	6.5.1
Alarm systems .....	15.7.4.2.1, A.15.7.4.2.1	Type 1 .....	6.4, A.6.4.1.1.1 to A.6.4.4.1.2.1
Essential electrical systems .....	6.4.2.2.3.2(5), 6.4.2.2.5.4(3), 6.5.2.2.2.1(7), 7.3.1.2.2.7(B)	Administration .....	6.4.4, A.6.4.4.1.1.4(A), A.6.4.4.1.2.1
Temporary operation of .....	6.5.2.2.3.4(B), A.6.5.2.2.3.4(B)	Branches .....	6.4.2.2, A.6.4.2.2.1 to A.6.4.2.2.6.2(C)
<b>Emergency call (nurse call system)</b> .....	7.3.3.1.6, 7.4.3.1.5	Distribution .....	6.4.2, A.6.4.2
<b>Emergency care, policies for</b> .....	1.3.3	Generator sets ....	6.4.1.1, 6.4.4.1.1, A.6.4.1.1.1 to A.6.4.1.1.17.1, A.6.4.4.1.1.4(A)
<b>Emergency generators</b> .....	15.5.1.3; <i>see also</i> Generator sets	Maintenance and testing .....	6.4.4.1, A.6.4.4.1.1.4(A), A.6.4.4.1.2.1
<b>Emergency management</b> .....	Chap. 12; <i>see also</i> Emergency procedures	Performance criteria and tests .....	6.4.3
Administration .....	12.5.3.6	Sources .....	6.4.1, A.6.4.1.1.1 to A.6.4.1.1.17.1
Category 1 and Category 2 requirements .....	12.5, A.12.5.3.1.2 to A.12.5.3.5	Uses .....	6.4.1.1.7, A.6.4.1.1.7.3
Committee for .....	12.2.3, A.12.2.3	Type 2 .....	6.4.1.1.6.1, 6.5, A.6.5.2.1.1 to A.6.5.2.2.4.2
Definition .....	3.3.44	Administration .....	6.5.4
General requirements .....	12.4	Distribution .....	6.5.2, A.6.5.2.1.1 to A.6.5.2.2.4.2
Medical air, loss of .....	5.2.3.5(2)	Generator sets .....	6.5.4.1.1
Mitigation .....	12.5.3.2	Maintenance and testing .....	6.5.4.1
Preparedness .....	12.5.3.3, A.12.5.3.3.6.1(5) to A.12.5.3.3.9.9	Performance criteria and tests .....	6.5.3
Responsibilities .....	12.2, A.12.2.1 to A.12.2.3.3	Sources .....	6.5.1, 6.5.3.1
Authority having jurisdiction .....	12.2.1, A.12.2.1		
Emergency management committee .....	12.2.3, A.12.2.3		
Senior management .....	12.2.2		
Safety and security .....	12.5.3.3.6.3, A.12.5.3.3.6.3		
Staff education .....	12.5.3.3.7		

Type 3 ..... 6.4.1.1.6.2, 6.6, A.6.6.2.1.1 to A.6.6.2.2.3.2  
Administration ..... 6.6.4  
Distribution ..... 6.6.2, A.6.6.2.1.1 to A.6.6.2.2.3.2  
Maintenance and testing ..... 6.6.4.1  
Performance criteria and tests ..... 6.6.3  
Sources ..... 6.6.1, 6.6.3.1  
**Evacuation, hyperbaric facilities** ..... 14.2.4.5.4  
**Evacuation, waste gas** ..... *see* Waste anesthetic gas disposal (WAGD) systems  
**Exhaust systems** ..... *see also* Ventilation  
Emergency systems ..... 6.4.2.2.5.4(4)  
Hyperbaric facilities ..... 14.2.9.2, A.14.2.9.2  
Medical gases or cryogenic liquid storage or transfilling areas ..... 9.3.7.5.3  
Vacuum or scavenging source ..... 5.1.3.7.7, 5.1.13.2.3.1(2), 5.3.8.3.11, A.5.3.8.3.11(8)  
Waste anesthetic gas disposal (WAGD) systems ..... 5.1.3.8.6  
**Exposed conductive surfaces**  
Definition ..... 3.3.50  
Tests ..... 6.3.3.1.1.2, 6.3.3.1.1.3  
**Extension cords** ..... 10.2.4, 10.5.2.3; *see also* Power cords  
**Exterior connections** ..... 12.5.3.3.6.6  
**Extinguishers, portable fire** ..... 14.2.5.1.5, 15.9.1, A.14.2.5.1.5, A.15.9.1  
**Extinguishing systems** ..... *see* Fire extinguishing systems

**-F-**

**Failure**  
Definition ..... 3.3.51, A.3.3.51  
Power sources ..... 6.4.3.2.2 to 6.4.3.2.8, 6.5.3.2.2 to 6.5.3.2.7, 6.6.3.2  
**Fault currents (definition)** ..... 3.3.52  
**Fault hazard currents (definition)** ..... 3.3.69.1  
**Feeders (definition)** ..... 3.3.53  
**Filters, air**  
Instrument air ..... 5.1.3.9.7, 5.1.13.2.3.1(4)  
Medical air ..... 5.1.3.6.3.8, 5.1.3.6.3.10(E), 5.1.3.6.3.10(F), 5.1.3.6.3.10(I), 5.2.3.5(1), A.5.1.3.6.3.10(F)  
**Final tie-in tests** ..... 5.1.12.3.9, 5.3.6.23.3.12  
**Fire alarm systems** ..... *see* Alarm systems  
**Fire blankets** ..... 14.2.5.1.5, A.14.2.5.1.5  
**Fire dampers or shutters** ..... 6.4.1.1.12.2(C), 6.4.1.1.12.5, 9.3.10.3.2.3, 9.3.10.3.5, 15.7.4.2.2, A.15.7.4.2.2  
**Fire detection systems** ..... 15.7, A.15.7.1 to A.15.7.4.3.2; *see also* Alarm systems; Smoke alarms/detectors  
Hyperbaric facilities ..... 14.2.5.4, 14.2.6.2, 14.3.6.3, A.14.2.5.4.2  
**Fire extinguishing systems and equipment** ..... 15.8, 15.9, 15.10, 15.11.3, 15.12, A.15.8.1.2, A.15.8.1.3, A.15.9.1, A.15.9.2.2, A.15.10, A.15.11.3; *see also* Fire protection  
Hyperbaric chambers ..... 14.2.5, A.14.2.5.1.4 to A.14.2.5.5  
Telecommunications facilities ..... 7.3.1.2.1.7, 7.3.1.2.3.9(B)  
**Fire fighters' emergency operations (elevator)** ..... 15.5.3.2  
**Fire hazards**  
Electrical systems ..... 6.2.1  
Gas systems ..... 5.1.2, 5.3.2  
Oxygen delivery equipment ..... 11.5.1.1.4, 11.5.1.2.2  
Oxygen-enriched atmospheres (OEAs) ..... 11.5.1.2.1  
Respiratory therapy ..... 11.5.1.1, 11.5.1.2, A.1.11.5.1.1.2, A.11.5.1.1.3  
**Fire prevention**  
Hyperbaric facilities ..... 14.3.1.5, A.14.3.1.5.1.1 to A.14.3.1.5.4.3  
Operating rooms ..... 15.13, A.15.13  
**Fire protection** ..... 12.5.3.3.6.5(5), Chap. 15  
Construction and compartmentation ..... 15.2  
Hyperbaric facilities ..... 14.2.5, 14.2.6, 14.3.1.4.7, 14.3.6.3, A.14.2.5.1.4 to A.14.2.5.5  
**Flammable (definition)** ..... 3.3.54, A.3.3.54  
**Flammable gases** ..... 14.3.1.5.2, A.14.3.1.5.2.2(2); *see also* Cylinders; Gases  
Definition ..... 3.3.55 *see also* Cylinders  
Hyperbaric facilities ..... 14.3.3.3

Special hazard protection for ..... 15.3, A.15.3.2  
Storage ..... 14.3.3.3  
**Flammable liquids** ..... 15.13.3, A.15.3.3.2  
Definition ..... 3.3.56  
In hyperbaric chambers ..... 14.3.1.5.2, A.14.3.1.5.2.2(2)  
Special hazard protection for ..... 15.3, A.15.3.2  
Use of ..... 11.5.1.2.3  
**Flammable substances and agents, misuse of** ..... 11.5.1.2  
**Flash point (definition)** ..... 3.3.57, A.3.3.57  
**Flexible connectors**  
Category 1 ..... 5.1.6.4, 5.1.6.6, 5.1.6.7, 5.1.10.11.6, 5.1.13.2.3.2  
Category 3 ..... 5.3.6.16, 5.3.6.21.7, 5.3.6.21.9, 5.3.7.7.5, 5.3.7.7.6, 5.3.7.8.6, 5.3.7.8.7  
**Flexible cord** ..... *see* Power cords  
**Flooring, antistatic** ..... *see* 14.2.2.4.2  
**Flow-control valves** ..... 11.5.3.3.1  
Definition ..... 3.3.58  
**Flowmeters**  
Definition ..... 3.3.59  
Labels on ..... 11.5.3.1.3  
Pressure compensated (definition) ..... 3.3.59.1  
**Footwear, nails in** ..... 14.3.1.5.3.3  
**Frequency (definition)** ..... 3.3.60, A.3.3.60  
**Fume hoods (definition)** ..... 3.3.61, A.3.3.61  
**Fundamentals** ..... Chap. 4  
**Furniture, hyperbaric facilities** ..... 14.3.6.2.1, A.14.3.6.2.1.2

**-G-**

**Gas cylinders** ..... *see* Cylinders  
**Gas equipment** ..... Chap. 11  
Administration ..... 11.5, A.11.5.1.1.3 to A.11.5.3.2  
Cylinders and containers ..... 11.2, 11.6, A.11.2.8  
Fire protection ..... 15.5.1.1  
Performance criteria and tests ..... 11.4, A.11.4.1.1 to A.11.4.3.3  
Qualification and training of personnel ..... 11.5.3.3.5  
Source ..... 11.2, A.11.2.8  
Use ..... 11.5.3, A.11.5.3.2  
**Gases** ..... *see also* Waste anesthetic gas disposal (WAGD) systems; *specific gases*  
Flammable ..... *see* Alarm systems *see* Flammable gases  
Handling ..... 14.3.3, A.14.3.3.4  
Medical ..... *see* Medical gases  
Monitoring, hyperbaric chambers ..... 14.2.8.3 to 14.2.8.8, A.14.2.8.6 to A.14.2.8.8  
Nonflammable ..... 11.3.1, 11.3.2, A.11.3.1, A.11.3.2 *see also* Medical gases  
Oxidizing (definition) ..... 3.3.128, A.3.3.128  
**Gasket material** ..... 14.2.3.1.2  
**Gas-powered systems (definition)** ..... 3.3.62; *see also* Category 3 drive gas systems  
**Gas systems** ..... *see* Medical gas systems  
**Gas tungsten arc welding (GTAW)** ..... 5.1.10.5.1, A.5.1.10.5.1.5  
**General anesthesia and levels of sedation/analgesia**  
Deep sedation/analgesia ..... 6.3.4.1.1, 6.3.4.1.3  
Definition ..... 3.3.63.1  
Definition ..... A.3.3.63  
General anesthesia ..... 6.3.4.1.1, 6.3.4.1.3  
Definition ..... 3.3.63.2  
Minimal sedation (anxolysis) (definition) ..... 3.3.63.3  
Moderate sedation/analgesia (conscious sedation) (definition) ..... 3.3.63.4  
**General care rooms** ..... *see* Patient care rooms  
**Generator sets**  
Alarm annunciator ..... 6.4.1.1.17, A.6.4.1.1.17.1  
Alternate power source ..... 6.6.1  
Design considerations ..... 6.4.1.1.1, A.6.4.1.1.1  
Exclusive use for essential electrical systems ..... 6.4.1.1.7.1  
Fire protection ..... 15.5.1.3  
Fuel supply ..... 6.4.1.1.3, 6.4.1.1.15  
Generator load shed circuits ..... 6.4.1.1.3  
Hyperbaric chambers ..... 14.2.7.2.1.2

Maintenance and testing ..... 6.4.4.1.1, 6.5.4.1.1, A.6.4.4.1.1.4(A)  
 Performance criteria and tests ..... 6.6.3.2  
 Safety devices ..... 6.4.1.1.16  
 Type 1 essential electrical systems ..... 6.4.1.1, 6.4.2, A.6.4.1.1.1 to A.6.4.1.1.17.1, A.6.4.2

**Germicides** ..... 15.13.3, A.15.3.3.2

**Governing body (definition)** ..... 3.3.65

**Grease interceptors** ..... 8.3.7

**Ground-fault circuit interrupters (GFCIs)** ..... 6.3.2.2.4.2, 6.3.2.2.8.7, A.6.3.2.2.4.2, A.6.3.2.2.8.7

    Definition ..... 3.3.66

**Ground-fault protection** ..... 6.3.2.2.4, 6.3.2.5, 14.2.7.4

    Tests ..... 6.3.3.4

**Grounding** ..... *see also* Grounding systems

    Appliances ..... 10.2.2.1

    Hyperbaric chambers ..... 14.2.7.4, 14.2.9.1

    Patient care rooms ..... 6.3.2.2.2, 6.3.2.2.5(2), 6.3.2.2.7, 6.3.3.1, A.6.3.2.2.2.2, A.6.3.2.2.7.1, A.6.3.2.2.7.3, A.6.3.3.1.1 to A.6.3.3.1.4

    Piping system ..... 5.1.14.1.2

    Special ..... 6.3.2.2.7, A.6.3.2.2.7.1, A.6.3.2.2.7.3

**Grounding circuit integrity** ..... 6.3.2.2.2.1

**Grounding conductors** ..... 10.2.3.2, A.10.2.3.2.4

**Grounding point**

    Patient equipment (definition) ..... 3.3.140

    Reference ..... 6.3.3.1.2

    Definition ..... 3.3.155

**Grounding systems**

    Definition ..... 3.3.68, A.3.3.68

    Tests ..... 6.3.3.1.1, A.6.3.3.1.1

**Guide (definition)** ..... 3.2.4

**-H-**

**Handlines** ..... 14.2.5.3

**Hand trucks** ..... 11.4.3.1

**Hazard current**

    Definition ..... 3.3.69

    Fault (definition) ..... 3.3.69.1

    Monitor (definition) ..... 3.3.69.2

    Total (definition) ..... 3.3.69.3

**Hazardous chemicals (definition)** ..... 3.3.70, A.3.3.70

**Hazards**

    Fire ..... *see* Fire hazards

    Nature of

        Hyperbaric facilities ..... 14.3.1.2, 14.3.1.5, A.14.3.1.2, A.14.3.1.5.1.1 to A.14.3.1.5.4.3

        Piped gas and vacuum systems ..... 5.1.2, 5.1.13.1, 5.2.2, 5.3.2, A.5.1.13.1

**Hazard vulnerability analysis (HVA)** ..... 12.5.2, 12.5.3.1, A.12.5.3.1.2, A.12.5.3.1.3(1)

**Headers**

    Central supply system ..... 5.1.3.5.8.1(6), 5.1.3.5.9, A.5.1.3.5.9

    Instrument air ..... 5.1.3.5.8.1(6), 5.1.3.5.9, A.5.1.3.5.9

**Health care facilities (definition)** ..... 3.3.71, A.3.3.71

**Heart, direct electrical pathway to**

    Definition ..... 3.3.38, A.3.3.38

    Protection of patients ..... 10.5.2.2

**Heating, adiabatic (definition)** ..... 3.3.2

**Heating, ventilating, and air conditioning (HVAC) systems** ..... Chap. 9

    Acoustics ..... 9.3.6

    Airborne contaminant control ..... 9.4.4, 9.5.3.5, 9.6.3.5

    Commissioning ..... 9.3.3

    Ductwork ..... 9.3.5

    Emergency plan ..... 12.5.3.3.6.5(4)

    Emergency power system room ..... 9.3.10, A.9.3.10.3.1

    Energy conservation ..... 9.3.2

    Fire protection ..... 15.5.2, A.15.5.2.1

Information technology and communications systems ..... 7.3.1.2.1.6, 7.3.1.2.2.7(E), 7.3.1.2.2.8(B), 7.3.1.2.3.8, 7.4.1.1.1, A.7.3.1.2.1.6(C)

Medical plume evacuation ..... 9.3.9

Piping ..... 9.3.4

Smoke detectors ..... 15.7.4.2.2, A.15.7.4.2.2

System category criteria ..... 9.2, A.9.2

Waste gas ..... 9.3.8

**Heating equipment**

    Essential electrical system generator sets ..... 6.4.1.1.12, 6.5.2.2.3.4(A), A.6.4.1.1.12, A.6.5.2.2.3.4(A)

    Water heating ..... 8.3.3, 8.4.3, 8.5.3, 8.6.3, A.8.5.3.2

**High-energy devices** ..... 14.3.2.1.2(3)

**High pressure (definition)** ..... 3.3.147.4

**Home care (definition)** ..... 3.3.72

**Hoods**

    Fume (definition) ..... 3.3.61, A.3.3.61

    Oxygen (definition) ..... 3.3.192, A.3.3.192

**Hose**

    Gas and vacuum systems ..... 5.1.6.4, 5.1.6.6, 5.1.6.7, 5.1.10.11.6, 5.3.6.16, 5.3.6.21.7

    Standpipe and hose systems ..... 15.9.2, A.15.9.2.2

**Hospital-based (definition)** ..... 3.3.74

**Hospitals** ..... A.12.1, A.12.1.1

    Definition ..... 3.3.73

    Governing body (definition) ..... 3.3.65

**Humidification**

    Hyperbaric facilities ..... 14.2.4.3, A.14.2.4.3.2

    Respiratory therapy ..... 11.4.2.4

**Humidifiers** ..... 11.4.2.5, 11.4.2.6

    Definition ..... 3.3.75

**Hydrostatic tests** ..... 14.2.1.1.9.1

**Hyperbaric (definition)** ..... 3.3.76

**Hyperbaric facilities** ..... Chap. 14

    Administration and maintenance ..... 14.3, A.14.3.1.2 to A.14.3.6.4

    Air supply, monitoring of ..... 14.2.8.6, A.14.2.8.6

    Chambers, classification ..... 14.1.2, A.14.1.2.2

    Communications and monitoring equipment ..... 14.2.8, A.14.2.8.2 to A.14.2.8.8

    Construction and equipment ..... 14.2, 14.3.2, A.14.2.1.1.1 to A.14.2.9.2, A.14.3.2.16 to A.14.3.2.6

    Electrical equipment ..... 10.5.4, A.10.5.4.5, A.10.5.4.6

    Electrical systems ..... 6.4.2.2.5.4(5), 14.2.7, A.14.2.7.1.4.1 to A.14.2.7.6.1.1

    Emergency depressurization capability ..... 14.2.4.5, A.14.2.4.5.3

    Emergency procedures ..... 14.3.1.4.3 to 14.3.1.4.6, A.14.3.1.4.5

    Fabrication of chamber ..... 14.2.2, A.14.2.2.1 to A.14.2.2.6

    Fire prevention ..... 14.3.1.5, A.14.3.1.5.1.1 to A.14.3.1.5.4.3

    Fire protection ..... 14.2.5, 14.2.6, 14.3.6.3, A.14.2.5.1.4 to A.14.2.5.5

Gases

    Handling of ..... 14.3.2.2, 14.3.3, A.14.3.2.2, A.14.3.3.4

    Monitoring of ..... 14.2.8.3 to 14.2.8.8, A.14.2.8.6 to A.14.2.8.8

Hazards, nature of ..... 14.3.1.2, 14.3.1.5, A.14.3.1.2, A.14.3.1.5.1.1 to A.14.3.1.5.4.3

Housing for ..... 14.2.1, A.14.2.1.1.1 to A.14.2.1.2.2

Ignition sources ..... 14.3.1.5.1, A.14.3.1.5.1.1

Illumination ..... 14.2.3

Intercommunications equipment ..... 14.2.8.2, A.14.2.8.2

Noncombustible (definition) ..... 3.3.121

Other fixtures and equipment ..... 14.2.9, 14.3.2, A.14.2.9.2, A.14.3.2.16 to A.14.3.2.6

Personnel ..... 14.3.1.3, 14.3.1.4, 14.3.1.5.3, 14.3.1.5.5, A.14.3.1.3.2 to A.14.3.1.3.5, A.14.3.1.4.1 to A.14.3.1.4.5, A.14.3.1.5.3

Rules and regulations ..... 14.3.1.3.4, 14.3.1.4, A.14.3.1.3.4, A.14.3.1.4.1 to A.14.3.1.4.5

Ventilation of chambers ..... 14.2.4, 14.2.9.2, A.14.2.4.1.2, A.14.2.9.2

Viewports ..... 14.2.2.6, A.14.2.2.6

Wiring and service equipment ..... 14.2.7.3 to 14.2.7.6,  
A.14.2.7.3 to A.14.2.7.6.1.1

**Hyperbaric oxygenation (definition)** ..... 3.3.77

**Hyperbaric stand-alone oxygen system (definition)** ..... 3.3.78

**Hypobaric**

  Definition ..... 3.3.79

  Electrical systems, facility ..... 6.4.2.2.5.4(6)

  Noncombustible (definition) ..... 3.3.122

**Hypoxia (definition)** ..... 3.3.80

**-I-**

**Identification** ..... *see* Labeling and identification

**Ignition sources** ..... *see also* Fire hazards

  Hyperbaric chambers ..... 14.3.1.5.1, A.14.3.1.5.1.1

  Respiratory therapy locations ..... 11.5.1.1, A.11.5.1.1.2,  
A.11.5.1.1.3

**Immediate restoration of service (definition)** ..... 3.3.81

**Impedance**

  Definition ..... 3.3.82, A.3.3.82

  Of isolated wiring ..... 6.3.2.6.2, A.6.3.2.6.2.1

  Limit ..... 6.3.3.1.6.2

  Measuring ..... 6.3.3.1.4

**Incident command system (ICS) (definition)** ..... 3.3.83

**Incinerators** ..... 15.6

**Inert gas bulk systems** ..... 5.1.3.3.1.13, A.5.1.3.3.1.13

  Definition ..... 3.3.21.1

**Information technology and communications systems** ..... Chap. 7, 15.7, A.15.7.1 to A.15.7.4.3.2; *see also* Alarm systems

  Category 1 ..... *see* Category 1 information technology and communications systems

  Category 2 ..... 7.4

    Infrastructure ..... 7.4.1

    Nurse call systems ..... 7.4.3.1

  Category 3 ..... 7.5

  Circuits, mechanical protection of ..... 6.4.2.2.6.6

  Emergency plan ..... 12.5.3.3.6.1, A.12.5.3.3.6.1(5)

  Essential electrical systems ..... 6.5.2.2.2.1(4), 7.3.1.2.2.7(B),  
7.3.1.2.2.7(C), 7.3.1.2.2.8(B), 7.4.1.1.1, A.6.5.2.2.2.1(4)

  Hyperbaric facilities ..... 14.2.8, A.14.2.8.2 to A.14.2.8.8

  Life safety branch ..... 6.4.2.2.3.2(3), A.6.4.2.2.3.2(3)

**Inhalation anesthetics** ..... *see* Anesthetic apparatus; Anesthetics; Anesthetizing locations

**In-line valves** ..... 5.1.4.9, 5.1.4.11

**Inspections**

  Category 1 piped gas and vacuum systems ..... 5.1.13.2.2.2,  
5.1.13.2.2.3, 5.1.13.2.3, 5.1.13.4.4, A.5.1.13.2.2.2,  
A.5.1.13.2.3.1(1) to A.5.1.13.2.3.1(11)

  Category 3 piped gas and vacuum systems ..... 5.3.6.10,  
5.3.6.23.1, 5.3.9.1

**Instructions**

  Category 1 piped gas and vacuum systems ..... 5.1.3.5.1,  
5.1.10.3.2, 5.1.10.6.2, 5.1.10.7.2, 5.1.10.11.8,  
5.1.12.3.14.3, 5.1.12.3.14.4(B), A.5.1.3.6.1

  Category 3 piped gas and vacuum systems ..... 5.3.9.3.7.3, 5.3.12.3

  Liquid oxygen equipment ..... 11.7.2

**Instrument air**

  Definition ..... 3.3.84

  Supply systems ..... 5.1.1.2, A.5.1.1.2 *see also* Compressed air systems (Category 3); Medical gas systems

    Category 1 piped gas and vacuum systems ..... 5.1.3.5(7),  
5.1.3.9, Table 5.1.11, 5.1.13.2.3.1(4), A.5.1.3.9,  
A.5.1.13.2.3.1(4)

    Alarms ..... 5.1.9.5, A.5.1.9.5

    Headers ..... 5.1.3.5.8.1(6), 5.1.3.5.9, 5.1.3.9.5, A.5.1.3.5.9

    Category 2 piped gas and vacuum systems ..... 5.2.3.8

**Insulation**

  Hyperbaric chambers, wiring and equipment inside ..... 14.2.7.3.6,  
A.14.2.7.3.6

  Maintenance and testing of ..... 6.4.4.1.2.2

**Integrity tests** ..... 10.3.1, A.10.3.1

**Intentional expulsion, site of (definition)** ..... 3.3.168, A.3.3.168

**Intermittent positive-pressure breathing (IPPB) (definition)** ..... 3.3.85

**Internal combustion engines** ..... 6.4.1.1.16.1

**Intrinsically safe**

  Circuits, hyperbaric chamber ..... 14.2.5.1.3.1, 14.2.7.3.7.5

  Definition ..... 3.3.86, A.3.3.86

**Invasive procedure (definition)** ..... 3.3.87

**Isolated ground receptacles** ..... 6.3.2.2.7.1, A.6.3.2.2.7.1

**Isolated patient leads (definition)** ..... 3.3.88

**Isolated power systems** ..... 6.3.2.2.8.6, 6.3.2.2.8.7, 6.3.2.2.9,  
6.3.2.6, A.6.3.2.2.8.7, A.6.3.2.6

  Definition ..... 3.3.89, A.3.3.89

  Tests ..... 6.3.3.3, 6.3.4.2.2

**Isolation switch, bypass** ..... 6.4.2.1.8, A.6.4.2.1.8.3

**Isolation transformers** ..... 6.3.2.6.1

  Definition ..... 3.3.90

**-J-**

**Joints** ..... 5.1.10.3, A.5.1.10.3.1

  Axially swaged ..... 5.1.10.3.1(4), 5.1.10.7

  Brazed ..... 5.1.10.3.1(1),  
5.1.10.4, 5.1.10.11.11, 5.3.6.2.3, 5.3.6.2.4, 5.3.6.3 to  
5.3.6.10, 5.3.7.2.3.1, 5.3.7.2.3.2, A.5.1.10.4.5, A.5.3.6.8

  Category 3 gas-powered devices ..... 5.3.7.2.3

  Memory metal ..... 5.1.10.3.1(3), 5.1.10.6

  Prohibited ..... 5.1.10.10

  Soldered ..... 5.3.7.2.3.3

  Special fittings ..... 5.1.10.9

  Threaded ..... 5.1.10.3.1(5), 5.1.10.8, 5.3.6.2.5, A.5.1.10.8(3)

  In vacuum and scavenging systems ..... 5.3.8.2.2(3), 5.3.8.2.3(3),  
5.3.8.2.4(4)

  Welded ..... 5.1.10.3.1(2), 5.1.10.5, A.5.1.10.5.1.5

**-L-**

**Labeled (definition)** ..... 3.2.5

**Labeling and identification**

  Cylinders and containers ..... 5.1.3.1, 5.3.10.2, 5.3.10.4,  
11.3.4, A.5.1.3.1.1

  Gas equipment ..... 11.5.3.1, 11.5.3.2, A.11.5.3.2

  Gas/vacuum systems ..... 5.1.11, 5.1.13.3, 5.2.3.1, 5.2.11,  
5.3.11, 5.3.13.3

  Alarm panels ..... 5.1.11.4

  Pipes ..... 5.1.11.1, 5.3.11.1

  Shutoff valves ..... 5.1.11.2, 5.3.11.2

  Station outlets and inlets ..... 5.1.11.3, 5.3.11.3

  Support gas ..... 5.1.14.9

  Verification of ..... 5.1.12.3.13, 5.1.14.2.3.1(5),  
5.1.14.2.3.1(8), 5.3.6.23.3.13, 5.3.9.2.5.8, 5.3.9.2.6.7

  Hyperbaric facilities ..... 14.2.5.1.7, 14.2.6.1, 14.3.1.4.7

  Oxygen ..... 11.5.3.1, 11.5.3.2, A.11.5.3.2

  Respiratory therapy ..... 11.5.3.1, 11.5.3.2, A.11.5.3.2

**Laboratories** ..... 6.3.2.3

  Definition ..... 3.3.91, A.3.3.91

  Electrical equipment and appliances ..... 10.5.5, A.10.5.5.1, A.10.5.5.2

  Fire protection ..... 15.4, 15.5.2.4

  Gas equipment ..... 11.4.3.2

  Heating, ventilating, and air conditioning (HVAC) systems ..... 9.3.1.2

  Ventilation ..... 15.5.2.4

**Laboratory work area (definition)** ..... 3.3.92, A.3.3.92

**Lasers** ..... 14.3.2.1.4, 15.13.3, A.15.3.3.2

**Laundry chutes** ..... 15.6

**Leakage current** ..... *see also* Touch current

  Fixed equipment ..... 10.3.4

  Limits ..... 10.3.6, A.10.3.6

  Tests ..... 10.3.3, 10.3.4, 10.3.6, A.10.3.3, A.10.3.6

**Leak detectant** ..... 5.1.12.2.3.5, 5.1.12.3.9.2, 5.3.6.23.2.3(E),  
5.3.6.23.3.12(B), 5.3.9.2.3.5, 5.3.9.2.4.4, 5.3.9.3.6.2

  Definition ..... 3.3.93

**Life safety branch** ..... 6.4.1.1.3, 6.4.2.2.1.1(1), 6.4.2.2.3, 6.4.2.2.4, 6.5.2.2.2, 7.3.1.2.2.7(B), A.6.4.2.2.3.2(3), A.6.4.2.2.4, A.6.5.2.2.2.1(4)  
 Definition ..... 3.3.94  
 Mechanical protection of ..... 6.4.2.2.6.4  
**Life support equipment, electrical** ..... 6.3.2.5.1  
 Definition ..... 3.3.42  
**Lighting**  
 Hyperbaric chambers ..... 14.2.7.3.15, A.14.2.7.3.15  
 Photographic lighting equipment ..... 14.3.2.1.3  
**Limited care facility (definition)** ..... 3.3.95  
**Limited-combustible material (definition)** ..... 3.3.96, A.3.3.96  
**Line isolation monitor** ..... 6.3.2.6.3, A.6.3.2.6.3.1 to A.6.3.2.6.3.4  
 Definition ..... 3.3.97  
 Tests ..... 6.3.3.3.2, 6.3.4.1.4  
**Liquids (definition)** .... 3.3.98, A.3.3.98; *see also* Combustible liquids; Flammable liquids; Oxygen  
**Listed (definition)** ..... 3.2.6, A.3.2.6  
**Local signal**  
 Bulk system operating status ..... 5.1.3.5.12.4, A.5.1.3.5.12.4  
 Definition ..... 3.3.99, A.3.3.99  
 Proportioning system for medical air ..... 5.1.3.6.3.15(C)(9), A.5.1.3.6.3.15(C)(9)  
**Lubricants** ..... 14.3.2.4, 14.3.6.2.1.4

**-M-**

**mA (definition)** ..... 3.3.100  
**Main lines, piping**  
 Definition ..... 3.3.144.2  
 Valves ..... 5.1.4.5, 5.1.11.2.4, A.5.1.4.5  
**Maintenance**  
 Piped gas and vacuum systems  
 Category 1 ..... *see* Category 1 piped gas and vacuum systems  
 Category 2 ..... 5.2.14, A.5.2.14  
 Category 3 ..... 5.3.13.4  
 Fire protection systems ..... 15.12  
**Management, emergency planning by** ..... 12.2.2  
**Manifolds** ..... 5.1.3.3.1.1, 5.1.3.3.1.2, 5.1.3.5(1), 5.1.3.5(2), 5.1.3.5.8.1(2), 5.1.9.2.4(1), 5.1.14.2.3.1(5), 5.3.6.21.3, 5.3.6.21.9, 5.3.6.21.11, 5.3.7.8.2(2), 5.3.7.8.5, 11.6.2, A.5.1.14.2.3.1(5)  
 Compressed air cylinder source equipment ..... 5.3.7.7.2(2), 5.3.7.7.4  
 Cryogenic liquid containers ..... 5.1.3.5.8.1(3), 5.1.3.5.11, 9.3.7.5, A.5.1.3.5.11, A.9.3.7.5.1  
 Cylinders without reserve supply, for ..... 5.1.3.5.8.1(1), 5.1.3.5.10, A.5.1.3.5.10, B.5.2.1  
 Definition ..... 3.3.101  
 Ventilation of manifold areas ..... 9.3.7.5, A.9.3.7.5.1  
**Manual extinguishing equipment** ..... 15.9, A.15.9.1, A.15.9.2.2  
**Manuals**  
 Anesthetizing equipment ..... 11.5.1.3.4  
 Electrical appliances ..... 10.5.3.1, 10.5.6.1  
 Respiratory equipment ..... 11.5.1.3.4  
**Manufactured assemblies**  
 Category 1 piped gas and vacuum systems ..... 5.1.6, 5.1.13.5, 5.1.14.2.3.2, A.5.1.6  
 Category 2 piped gas and vacuum systems ..... 5.2.6  
 Category 3 piped gas and vacuum systems ..... 5.3.6.23.2.1(C), 5.3.9.2.1.4  
 Definition ..... 3.3.102, A.3.3.102  
**Manufacturer's instructions** ..... *see* Instructions; Manuals  
**Masks**  
 Definition ..... 3.3.103  
 Oxygen mask microphones ..... 14.2.8.2.2  
**Measurement, units of** ..... 1.5, A.1.5  
**Media control** ..... 13.6, A.13.6  
**Medical air** ..... 5.1.1.2, A.5.1.1.2; *see also* Medical gas systems  
 Alarms ..... 5.1.3.6.3.9, 5.1.3.6.3.13, A.5.1.3.6.3.9  
 Category 1 supply systems ..... 5.1.3.6, A.5.1.3.6, B.5.2.6 to B.5.2.8  
 Category 2 supply systems ..... 5.2.3.5  
 Definition ..... 3.3.104, A.3.3.104  
 Designation colors/operating pressures ..... Table 5.1.11  
 Dryers ..... 5.1.3.6.3.3, 5.1.3.6.3.7, 5.1.3.6.3.10(E), 5.1.3.6.3.10(F), 5.1.3.6.3.10(I), 5.2.3.5(1), A.5.1.3.6.3.10(F)  
 Filters ..... 5.1.3.6.3.8, 5.1.3.6.3.10(E), 5.1.3.6.3.10(F), 5.1.3.6.3.10(I), A.5.1.3.6.3.10(F)  
 Hyperbaric facilities ..... 14.2.1.6  
 Proportioning system for medical air (USP) ..... 5.1.3.5(8), 5.1.3.6.3.15, A.5.1.3.6.3.15(C)(9), A.5.1.3.6.3.15(A)(9)  
 Components ..... 5.1.3.6.3.15(C), A.5.1.3.6.3.15(C)(9)  
 Definition ..... 3.3.104.1  
 Location ..... 5.1.3.6.3.15(B)  
 Tests ..... 5.1.12.3.14.4  
 Purity test ..... 5.1.12.3.12  
 Quality monitoring ..... 5.1.3.6.3.14, B.5.2.6, B.5.2.7  
 Receivers ..... 5.1.3.6.3.6, 5.1.3.6.3.10(D), A.5.1.3.6.3.10(D)  
 Regulators ..... 5.1.3.6.3.10(E), 5.1.3.6.3.10(F), 5.1.3.6.3.10(I), A.5.1.3.6.3.10(F)  
**Medical air compressors** *see also* Compressed air systems (Category 3)  
 Category 1 ..... 5.1.3.5(4), 5.1.3.6.1, 5.1.3.6.3, 5.1.3.6.3.10(B), 5.1.13.4.7(1), A.5.1.3.6.1, A.5.1.3.6.3  
 Alarms ..... 5.1.3.6.3.9, 5.1.3.6.3.13, 5.1.9.5, A.5.1.3.6.3.9, A.5.1.9.5  
 Electrical power and control ..... 5.1.3.6.3.11  
 Instrument ..... 5.1.3.9.3.3, 5.1.3.9.4  
 Intake ..... 5.1.3.6.3.12, 5.1.3.9.6, A.5.1.3.9.6  
 Tests ..... 5.1.12.3.14.3  
 Category 2 ..... 5.2.3.5(1)  
 Definition ..... 3.3.105  
 Electrical power and control ..... 6.4.1.1.3, 6.4.2.2.5.3(A)(3)  
 Intake ..... 14.2.4.2, A.14.2.4.2.1  
**Medical/dental office (definition)** ..... 3.3.106, A.3.3.106  
**Medical gases** ..... 5.1.1.2, A.5.1.1.2; *see also specific gases*  
 Concentration test ..... 5.1.12.3.11, 5.3.6.23.3.11, A.5.1.12.3.11(3)  
 Definition ..... 3.3.107  
 Patient medical gas (definition) ..... 3.3.142  
 Permitted locations ..... 5.1.3.5.2  
**Medical gas rails (MGRs)** ..... *see* Surface-mounted medical gas rail systems  
**Medical gas supply systems, Category 3** ..... 5.3.6, A.5.3.6.8 to A.5.3.6.23.3.11  
 Alarms ..... 5.3.6.22  
 Brazing procedures ..... 5.3.6.3 to 5.3.6.10, A.5.3.6.8  
 Dispensing devices, piping outlets for connection to ..... 5.3.6.18  
 Distribution piping ..... 5.3.6.2  
 Emergency shutoff valve ..... 5.3.6.19, A.5.3.6.19.1  
 Hose and flexible connectors ..... 5.3.6.16  
 Installer qualifications ..... 5.3.6.1  
 Locations of gas source equipment ..... 5.3.6.20  
 Performance criteria and tests ..... 5.3.6.23, A.5.3.6.23.2.3(E) to 5.3.6.23.3.11  
 Piping ..... 5.3.6.11 to 5.3.6.15, A.5.3.6.11.2  
 Source equipment ..... 5.3.6.20, 5.3.6.21  
 Station outlets ..... 5.3.6.17, A.5.3.6.17  
**Medical gas systems** ..... Chap. 5; *see also* Category 1 piped gas and vacuum systems; Category 2 piped gas and vacuum systems; Category 3 piped gas and vacuum systems; Cylinders; Gas equipment; Medical gases; Medical-surgical vacuum systems; Supply systems; Waste anesthetic gas disposal (WAGD) systems  
 Category 1 ..... *see* Category 1 piped gas and vacuum systems  
 Category 2 ..... *see* Category 2 piped gas and vacuum systems  
 Category 3 ..... *see* Category 3 piped gas and vacuum systems  
 Definition ..... 3.3.108  
 Distribution, piped ..... *see* Piped distribution systems  
 Emergency plan ..... 12.5.3.3.6.5(8)  
 Manufactured assemblies to use with ..... *see* Manufactured assemblies  
 Nitrous oxide ..... *see* Nitrous oxide  
 Storage or transfilling of gases, ventilation for ..... 9.3.7, A.9.3.7.3, A.9.3.7.5.1  
**Medical plume evacuation** ..... 9.3.9



**Medical-surgical vacuum (definition)** ..... 3.3.110

**Medical-surgical vacuum systems** ..... 5.1.1.3, Chap. 5;  
*see also* Category 3 vacuum systems

Alarms ..... 5.1.3.7.4, 5.1.3.7.8

Category 1 ..... 5.1.3.5(5), 5.1.3.7, 5.1.10.3.1, 5.1.10.3.2,  
5.1.12.3.14.5, 5.1.14.1.3, 5.1.14.1.4, 5.1.14.3, 5.1.15,  
A.5.1.3.7, A.5.1.10.3.1, A.5.1.14.1.3, A.5.1.14.1.4,  
A.5.1.15

Conversion to gas system ..... 5.1.10.11.9.2

Designation colors ..... Table 5.1.11

Electrical power and control ..... 5.1.3.7.6

Maintenance ..... 5.1.14.2, A.5.1.14.2.1 to A.5.1.14.2.3.1(11)

Operating pressures ..... Table 5.1.11

Piping ..... 5.1.3.7.5, 5.1.10.2, 5.1.14.4.7(3)

Shutoff valves ..... 5.1.4.1, B.5.2.17

Special precautions ..... 5.1.14.1.3, 5.1.14.1.4, A.5.1.14.1.3,  
A.5.1.14.1.4

Standard designation colors and operating  
pressures ..... Table 5.1.11

Station outlets/inlets ..... 5.1.5, A.5.1.5, B.5.2.18

Category 2 ..... 5.2.3.6

Definition ..... 3.3.111

Emergency plan ..... 12.5.3.3.6.5(8)

Exhaust ..... 5.1.3.7.7, 5.1.13.2.3.1(2), 5.3.8.3.11, A.5.3.8.3.11(8)

Installers, qualification of ..... 5.1.10.11.10, 5.1.10.11.11, 5.3.6.1

Labeling ..... 5.1.13.3

Manufactured assemblies to use with ..... *see* Manufactured  
assemblies

Tests ..... 5.1.14.2.3.1(2), 5.3.9, A.5.1.14.2.3.1(2) *see also*  
Cross-connections

Final standing test ..... 5.3.9.3.3

Initial pressure test ..... 5.3.6.23.2.3, 5.3.6.23.2.6,  
A.5.3.6.23.2.3(E)

Leak tests ..... 5.3.9.2.4

Maintenance ..... 5.1.14.2.3.1(2), A.5.1.14.2.3.1(2)

Source system ..... 5.1.12.3.14.5

Standing vacuum test ..... 5.1.12.2.7, A.5.1.12.2.7.5

**Microphones, oxygen mask** ..... 14.2.8.2.2

**Moisture indicators** ..... 5.3.7.6.1(17), 5.3.7.6.3, A.5.3.7.6.3

**Monitor hazard current (definition)** ..... 3.3.69.2

**Motor load transfer** ..... 6.4.2.1.5.13

**Multiple treatment facility (definition)** ..... 3.3.112

**mV (definition)** ..... 3.3.113, 3.3.115

-N-

**Nasal cannula (definition)** ..... 3.3.114

**Nasal catheter (definition)** ..... 3.3.115

**Nebulizers** ..... 11.4.2.5, 11.4.2.6

Definition ..... 3.3.116

**Negative pressure (definition)** ..... 3.3.117

**Nitrogen** ..... 5.1.1.2, A.5.1.1.2; *see also* Medical gases; Medical gas  
systems; Support gases

Category 3 drive gas system source equipment ..... 5.3.7.8,  
A.5.3.7.8

Category 1 medical air proportioning system ..... 5.1.3.6.3.15,  
A.5.1.3.6.3.15(C)(9), A.5.1.3.6.3.15(A)(9)

Category 1 medical air supply systems ..... 5.1.3.6.1(1)

Definition ..... 3.3.118

Joints, purging of ..... 5.1.10.4.5, 5.3.6.8, A.5.1.10.4.5, A.5.3.6.8

NF (oil-free, dry)

Category 1 medical air supply systems ..... 5.1.3.6.1(1)

Definition ..... 3.3.118.1

For purge ..... 5.1.10.4.5.1, 5.3.6.8.1

For tests ..... 5.1.12.2.1.2, 5.1.12.2.2, 5.1.12.3.1.2, 5.1.12.3.5.1(F),  
5.3.6.23.2.1(B), 5.3.6.23.2.4(C), 5.3.6.23.2.5(A),  
5.3.6.23.3.1(D), 5.3.6.23.3.3(2), 5.3.6.23.3.4(2),  
5.3.6.23.3.5(B), 5.3.6.23.3.6(E), 5.3.6.23.3.8(1),  
5.3.6.23.3.9(1), 5.3.6.23.3.10(B), 5.3.9.2.1.3, 5.3.9.2.2,  
5.3.9.2.5.3, 5.3.9.2.7.2, 5.3.9.3.1.3, 5.3.9.3.2(1),  
5.3.9.3.4(7)

**Nitrogen narcosis (definition)** ..... 3.3.119

**Nitrous oxide**

Definition ..... 3.3.120

Handling ..... 11.6.1.3

Storage ..... 11.3.2.2, 11.6.1.3

**Nitrous oxide systems** ..... 5.1.1.2, A.5.1.1.2;  
*see also* Medical gas systems

Bulk (definition) ..... 3.3.21.2

Designation colors/operating pressures ..... Table 5.1.11

Indoor locations for ..... 5.1.3.3.1.6

Supply systems ..... 5.1.3.3.1.8, 5.1.3.3.1.10, 5.1.3.5.2, 5.1.3.5.4(2)

**Noncombustible (hyperbaric) (definition)** ..... 3.3.121

**Noncombustible (hypobaric) (definition)** ..... 3.3.122

**Noncombustible material (definition)** ..... 3.3.123

**Nonflammable (definition)** ..... 3.3.124

**Nonflammable anesthetic agent (definition)** ..... 3.3.125, A.3.3.125;  
*see also* Anesthetics

**Nonflammable anesthetizing location** ..... *see* Anesthetizing locations

**Nonflammable gases** ..... 11.3.1, 11.3.2, A.11.3.1, A.11.3.2; *see also*  
Medical gases

**Nonflammable medical gas systems** ..... *see* Medical gas systems

**Nonflammable compressed air** ..... 8.3.5

Definition ..... 8.1.4.1

**Nurse call systems** ..... 7.3.3.1, 7.4.3.1

**Nursing homes (definition)** ..... 3.3.127

-O-

**Occupant notification** ..... 15.7.4, A.15.7.4.2.1 to A.15.7.4.3.2

**Operating rooms**

Electrical receptacles for ..... 6.3.2.2.6.2(C)

Emergency procedures ..... 15.13.3.9

Fire loss prevention ..... 15.13, A.15.13

Hyperbaric chambers ..... 14.2.4.3.3

Nurse call systems ..... 7.3.3.1.7.1

Personnel orientation and training ..... 15.13.3.10

Wet procedure locations ..... 6.3.2.2.8.7, A.6.3.2.2.8.7

**Operating supply (definition)** ..... 3.3.171.1

**Outlets**

Gas dispensing devices piping connections ..... 5.3.6.18

Gas-powered device supply systems ..... 5.3.9.1.6, 5.3.11.3

Nitrogen support gas ..... 5.1.13.4

Vacuum and scavenging systems ..... 5.3.9.1.6, 5.3.11.3

**Outlets, electrical** ..... *see* Receptacles

**Overcurrent protection** ..... 6.3.2.2.1.3, 6.4.2.1.2.1

**Oxidizing gas (definition)** ..... 3.3.128

**Oxygen** ..... *see also* Medical air; Medical gases

Ambulatory patients receiving ..... 11.5.2.4

Compatibility ..... 14.3.2.3, 14.3.2.4

Definition ..... 3.3.129, A.3.3.129

Designation colors/operating pressures ..... Table 5.1.11

Gaseous (definition) ..... 3.3.129.1

Handling ..... 11.6.1.3, 11.6.2, 14.3.2.2 to 14.3.2.4, A.14.3.2.2

Liquid ..... 14.3.3.2

Definition ..... 3.3.129.2, A.3.3.129.2

Equipment ..... 11.7, A.11.7.3.1 to A.11.7.3.5.1.1

Transferring ..... 11.5.2.3, 11.7.3.5, A.11.7.3.5.1.1

Monitoring ..... 14.2.8.4

Storage ..... 5.1.3.1.9, 11.3.2.2, 11.6.1.3, 14.3.2.2, A.14.3.2.2

Therapy ..... *see* Hyperbaric facilities

Toxicity (hyperbaric) (definition) ..... 3.3.134, A.3.3.134

Transferring ..... 11.5.2.2, 11.5.2.3, 11.7.3.5, A.11.7.3.5.1.1

**Oxygen cylinders** ..... *see* Cylinders

**Oxygen delivery equipment** ..... 10.5.4.5, A.10.5.4.5;  
*see also* Cylinders; Pipe and piping, gas

Definition ..... 3.3.130, A.3.3.130

Hazards ..... 11.5.1.1.4, 11.5.1.2.2

Maintenance of ..... 11.5.1.3.3

**Oxygen enclosures** ..... 11.4.2.2

**Oxygen-enriched atmosphere (OEA)**

Definition ..... 3.3.131

Electrical appliances in ..... 10.5.4, A.10.5.4.5, A.10.5.4.6

Hazards of ..... 11.5.1.2.1

Labeling of equipment for use in ..... 11.5.3.1.1  
**Oxygen hoods (definition)** ..... 3.3.132, A.3.3.132  
**Oxygen index (definition)** ..... 3.3.133  
**Oxygen systems** ..... 5.1.1.2, A.5.1.1.2, B.5.3; *see also* Cylinders; Medical gas systems; Oxygen delivery equipment; Pipe and piping, gas  
 Bulk (definition) ..... 3.3.21.3, A.3.3.21.3  
 Hyperbaric facilities ..... 14.2.1.4  
 Indoor locations for ..... 5.1.3.3.1.6  
 Supply systems ..... 5.1.3.3.1.9, 5.1.3.5.2, 5.1.3.5.4(2)  
 Emergency oxygen supply connection (EOSC) ..... *see* Emergency oxygen supply connection (EOSC)  
**Oxygen USP**  
 Category 1 medical air proportioning system ..... 5.1.3.6.3.15, A.5.1.3.6.3.15(C) (9), A.5.1.3.6.3.15(A) (9)  
 Category 1 medical air supply systems ..... 5.1.3.6.1(1)  
 Definition ..... 3.3.135

**-P-**

**Paper** ..... 14.3.2.1.6, 14.3.2.1.7, A.14.3.2.1.6  
**Partial pressure (definition)** ..... 3.3.147.5, A.3.3.147.5  
**Particulate test, piping** ..... 5.1.12.3.7, 5.3.6.23.3.8  
**Patient bed locations**  
 Call station ..... 7.3.3.1.2, 7.3.3.1.3, 7.4.3.1.2  
 Definition ..... 3.3.136  
 Electrical receptacles for ..... 6.3.2.2.6.2(A), 6.3.2.2.6.2(B)  
 Liquid oxygen storage ..... 11.7.4  
**Patient-care-related appliances** ..... 10.2, 10.3, 10.5.6, 14.2.7.3.17, A.10.2.3.2.4 to A.10.2.3.6(5), A.10.3.1 to A.10.3.6, A.10.5.6.2, A.14.2.7.3.17  
 Definition ..... 3.3.137  
**Patient care rooms** ..... 1.3.4; *see also* Electrical systems  
 Basic care rooms ..... 1.3.4.1(3), 6.3.2.2.10.4  
 Definition ..... 3.3.138.1, A.3.3.138.1  
 Critical care rooms ..... 1.3.4.1(1), 6.3.2.2.1.2, 6.3.2.2.1.3(C)  
 Definition ..... 3.3.138.2, A.3.3.138.2  
 Electrical receptacles ..... 6.3.2.2.6.2(B)  
 Essential electrical systems ..... 6.3.2.2.10.1, 6.3.2.2.10.3  
 Generator load shed circuits ..... 6.4.1.1.3  
 Ground-fault protection ..... 6.3.2.5.1  
 Nurse call systems ..... 7.3.3.1.7.1  
 Definition ..... 3.3.138, A.3.3.138  
 Electrical systems ..... 6.3.2.2, 6.3.3.1, 6.3.3.2, 6.3.3.3.1, A.6.3.2.2.1 to A.6.3.2.2.8.7, A.6.3.3.1.1 to A.6.3.3.1.4  
 General care rooms ..... 1.3.4.1(2), 6.5.2.2.3.4(A)  
 Definition ..... 3.3.138.3, A.3.3.138.3  
 Essential electrical systems ..... 6.3.2.2.10.2, 6.3.2.2.10.3  
 Liquid oxygen storage ..... 11.7.4  
 Sprinklers ..... 15.8.1.3, A.15.8.1.3  
 Support rooms (definition) ..... 3.3.138.4, A.3.3.138.4  
**Patient care vicinity**  
 Definition ..... 3.3.139  
 Electrical equipment, testing of ..... 10.3.4.1  
**Patient equipment grounding point (definition)** ..... 3.3.140  
**Patient leads** ..... 10.3.6, A.10.3.6; *see also* Electrical wiring  
 Definition ..... 3.3.141, A.3.3.141  
 Isolated (definition) ..... 3.3.88  
**Patient medical gas (definition)** ..... 3.3.142; *see also* Medical air; Nitrous oxide; Oxygen  
**Performance tests**  
 Category 1 piped gas and vacuum systems ..... 5.1.6.1(4), 5.1.6.2, 5.1.12, 5.1.14.10, A.5.1.12, B.5.1  
 Category 2 piped gas and vacuum systems ..... 5.2.12  
 Category 3 piped gas and vacuum systems ..... 5.3.6.23, 5.3.9, A.5.3.6.23.2.3(E) to 5.3.6.23.3.11  
**Photographic lighting equipment** ..... 14.3.2.1.3  
**Physicians, discretionary use of nonconforming materials** ..... 14.3.1.5.4.4  
**Pin-index safety system** ..... 11.4.1.2, A.11.4.1.2  
**Pipe and piping, gas**  
 Branch (lateral) line (definition) ..... 3.3.144.1

Breaching or penetrating ..... 5.1.10.11.12, 5.1.13.4.6  
 Category 1 ..... 5.1.3.6.3.10, 5.1.15, A.5.1.3.6.3.10(D), A.5.1.3.6.3.10(F), A.5.1.15  
 Distribution ..... 5.1.10, 5.1.14.8, A.5.1.10.1.4 to A.5.1.10.8(3)  
 Supply ..... 5.1.3.6.3.10, 5.1.3.7.5, 5.1.3.9.9, A.5.1.3.6.3.10(D), A.5.1.3.6.3.10(F)  
 Support gas ..... 5.1.13.9  
 Category 3 ..... 5.3.6.11 to 5.3.6.15, 5.3.6.21.9, 5.3.7.8.3, 5.3.9.1.6, 5.3.9.2.2 to 5.3.9.2.8, 5.3.9.3.2 to 5.3.9.3.7, 5.3.11.1, 5.3.13.2, 5.3.13.4.3, A.5.3.6.11.2  
 Distribution ..... 5.3.6.2, 5.3.12.2.1  
 Gas-powered devices ..... 5.3.7.2 to 5.3.7.4, 5.3.12.2.2  
 Vacuum and scavenging systems ..... 5.3.8.2, 5.3.8.3, 5.3.12.2.2, 5.3.13.2, 5.3.13.4.4(4), A.5.3.8.3.9 to A.5.3.8.3.11(8)  
 Category 2 distribution piping ..... 5.2.10  
 Definitions ..... 3.3.144  
 Fire protection ..... 15.5.1.1  
 Ground, use as ..... 5.1.14.1.2  
 Hyperbaric facilities ..... 14.2.1.3, 14.2.9.3, A.14.2.1.3.1  
 Installation ..... 5.1.10.11, 5.3.6.11, 5.3.7.3, 5.3.8.3, A.5.3.6.11.2, A.5.3.8.3.9 to A.5.3.8.3.11(8)  
 Instrument air systems ..... 5.1.3.9.9  
 Interconnections, prohibited ..... 5.1.10.11.7  
 Labeling ..... 5.1.11.1, 5.3.11.1  
 Main line ..... 5.1.4.5, 5.1.11.2.4, A.5.1.4.5  
 Definition ..... 3.3.144.2  
 Maintenance ..... 5.1.15, A.5.1.15  
 Manufacturer's instructions ..... 5.1.10.11.8  
 Special precautions ..... 5.1.14.1, 5.3.14.2, A.5.1.14.1.1 to A.5.1.14.1.4  
 Support ..... 5.1.10.11.4, 5.3.6.12, 5.3.7.3.3, 5.3.8.3.3, 5.3.8.3.4  
 Tests  
 Gas-powered devices ..... 5.3.9.1.6, 5.3.9.2.2, 5.3.9.2.3, 5.3.9.2.5, 5.3.9.2.7, 5.3.9.2.8, 5.3.9.3.5 to 5.3.9.3.7  
 Installer performed tests ..... 5.1.12.2, 5.3.13.4.3, A.5.1.12.2.3.5 to A.5.1.12.2.7.5, B.5.1  
 System verification ..... 5.1.12.3, 5.1.14.4.6, 5.3.6.23.3, 5.3.13.4.3, A.5.1.12.3.2, A.5.1.12.3.8  
 Vacuum and scavenging systems ..... 5.3.9.1.6, 5.3.9.2.3 to 5.3.9.2.6, 5.3.9.3.3, 5.3.9.3.4, 5.3.9.3.6, 5.3.9.3.7  
 Underground piping outside of buildings ..... 5.1.10.11.5, 5.3.6.13, 5.3.7.3.4, 5.3.8.3.5  
 Underground piping within buildings/within floor slabs ..... 5.3.6.14, 5.3.6.15, 5.3.7.3.5, 5.3.7.3.6, 5.3.8.3.6, 5.3.8.3.7  
**Piped distribution systems** ..... 5.1.10, 5.2.10, 5.3.6.2, 5.3.6.21.9, 5.3.7.8.3, 5.3.9.3.7.2, 5.3.12.2.1, A.5.1.10.1.4 to A.5.1.10.8(3); *see also* Central supply systems  
 Definition ..... 3.3.143  
**Piped gas systems** ..... *see* Medical gas systems  
**Piping, heating, cooling, ventilating, and process systems** ..... 9.3.4  
**Plugs (attachment plugs, caps)** ..... 10.2.2.2, 14.2.7.3.17.6(3)  
 Definition ..... 3.3.145  
**Plumbing** ..... Chap. 8  
 Building system categories, criteria for ..... 8.2, A.8.2  
 Fixtures ..... 8.3.8  
 General requirements ..... 8.3  
 Grease interceptors ..... 8.3.7  
 Nonmedical compressed air ..... 8.3.5  
 Definition ..... 8.1.4.1  
 Potable and nonpotable water ..... 8.3.1, 8.3.2  
 Special use water systems ..... 8.3.6  
 Wastewater ..... 8.3.9 to 8.3.11  
 Water conditioning ..... 8.3.4  
 Water heating ..... 8.3.3  
**Portable equipment** ..... *see* Equipment, portable  
**Positive-negative pressure breathing (definition)** ..... 3.3.146  
**Positive pressure**  
 Air/waste separator drainage ..... 5.3.8.3.10.5  
 Breaching or penetrating of medical gas piping ..... 5.1.10.11.12.1  
 Change in system ..... 5.1.10.11.9.1  
 Definition ..... 3.3.147.6

Final line regulation ..... 5.1.13.2.3.1(7)  
Indicators ..... 5.1.8.1.3, A.5.1.8.1.3  
Joints for positive pressure gas systems ..... 5.1.10.3.1, A.5.1.10.3.1  
Labeling of systems ..... 5.1.11.1.1(3), 5.1.11.2.2  
Telecommunications facilities, for ..... 7.3.1.2.1.6(C),  
7.3.1.2.2.8(C), A.7.3.1.3.1.6(C)  
**Power cords** ..... 10.2.3, 10.5.2.3, A.10.2.3.2.4 to A.10.2.3.6(5)  
Appliances ..... 6.4.2.2.6.5  
Hyperbaric chambers ..... 14.2.7.3.9, 14.2.7.3.17.6  
Patient care rooms ..... 6.3.2.2.8.5  
**Power systems** ..... *see* Electrical systems  
**Pressure**  
Absolute (definition) ..... 3.3.147.1  
Ambient (definition) ..... 3.3.147.2  
Gauge (definition) ..... 3.3.147.3  
High (definition) ..... 3.3.147.4  
Multiple, central supply system ..... 5.1.3.5.7  
Negative (definition) ..... 3.3.117  
Partial (definition) ..... 3.3.147.5, A.3.3.147.5  
Positive ..... *see* Positive pressure  
Standard operating pressures, gas and vacuum  
systems ..... Table 5.1.11  
Working (definition) ..... 3.3.147.7, A.3.3.147.7  
**Pressure indicators** ..... 5.1.8, 5.1.14.6, 5.2.8, 5.3.7.6.1(16),  
A.5.1.8.1.3, B.5.2.5, B.5.2.14  
**Pressure-reducing regulators** ..... 11.2.5 to 11.2.7, 11.5.3.1.2,  
11.5.3.1.3  
Definition ..... 3.3.148, A.3.3.148  
**Pressure regulators**  
Air compressors ..... 5.3.7.6.1(14), 5.3.7.7.2(3)  
Final line ..... 5.1.3.5.5, 5.1.3.6.3.15(C)(10), 5.1.13.2.3.1(7)  
Nitrogen purge ..... 5.1.10.4.5.3  
Nitrogen source equipment ..... 5.3.7.8.2(3)  
**Pressure relief valves** ..... 5.3.13.4.4(1), 14.3.4.1.1.1  
Air compressors ..... 5.3.7.6.1(15), 5.3.7.6.4, 5.3.7.7.2(5),  
5.3.7.7.7  
Central supply systems ..... 5.1.3.5.6  
Emergency oxygen supply connection (EOOSC) ..... 5.1.3.5.13.2(5)  
Medical air supply systems ..... 5.1.3.6.3.15(C)(8)  
Medical air systems ..... 5.1.3.6.3.10(J)  
Medical gas source equipment ..... 5.3.6.21.5, 5.3.6.21.6  
Nitrogen source equipment ..... 5.3.7.8.2(5), 5.3.7.8.2(6)  
**Pressure tests**  
Individual pressurization ..... 5.1.12.3.3.1  
Initial pressure ..... 5.1.12.2.3, 5.3.6.23.2.3, 5.3.6.23.2.6,  
A.5.1.12.2.3.5, A.5.3.6.23.2.3(E)  
Operational pressure ..... 5.1.12.3.10  
Pressure differential ..... 5.1.12.3.3.2  
Standing pressure ..... 5.1.6.1(4), 5.1.6.2, 5.1.12.2.6, 5.1.12.3.2,  
5.3.6.23.2.6, 5.3.6.23.3.3, 5.3.9.2.8, 5.3.9.3.2,  
A.5.1.12.2.6.5, A.5.1.12.3.2  
Verifier operational pressure ..... 5.3.6.23.3.10  
**Pressure vessels** ..... *see* Hyperbaric facilities  
**Prime movers** ..... 6.4.1.1.1.2(4)  
**Procedure room (definition)** ..... 3.3.149  
**Psia (pounds per square inch absolute) (definition)** ..... 3.3.150  
**Psig (pounds per square inch gauge) (definition)** ..... 3.3.151,  
3.3.151  
**Pumps, vacuum** ..... *see* Vacuum pumps  
**Purge test, piping** ..... 5.1.12.2.5, 5.1.12.3.6, 5.3.6.23.2.5, 5.3.6.23.3.7,  
5.3.9.2.7  
**Purity test**  
Medical air ..... 5.1.12.3.12  
Piping ..... 5.1.12.3.8, 5.3.6.23.3.9, A.5.1.12.3.8  
**Purpose of standard** ..... 1.2

**-R-**

**Radiation equipment, hyperbaric chambers** ..... 14.3.2.6, A.14.3.2.6  
**Reactance (definition)** ..... 3.3.152  
**Reactive material (definition)** ..... 3.3.153

**Receptacles**

Amperage and ..... 6.3.2.2.6.4  
Anesthetizing locations ..... 6.3.4.1.1, 6.3.4.1.3  
Definition ..... 3.3.154  
Emergency systems ..... 6.4.2.2.6.2, 6.6.2.2.3.2, A.6.4.2.2.6.2(C),  
A.6.6.2.2.3.2  
Grounding of ..... 6.3.2.2.2.4, 6.3.2.2.6.7.1  
Hyperbaric chambers ..... 14.2.7.3.10, A.14.2.7.3.10  
Laboratories ..... 6.3.2.2.3  
Life safety and equipment branches ..... 6.5.2.2.4.2,  
A.6.5.2.2.4.2  
Multiple outlet connection, for ..... 10.2.3.6,  
A.10.2.3.6(2) to A.10.2.3.6(5)  
Number of ..... 6.3.2.2.6.2  
Other services, for ..... 6.3.2.2.6.5  
Polarity of ..... 6.3.2.2.6.3  
Selected (definition) ..... 3.3.162  
Special-purpose outlets ..... 6.3.2.2.1.4, 6.3.2.2.6.1(B)  
Telecommunications facilities ..... 7.3.1.2.1.5(C), 7.3.1.2.2.7(C),  
7.3.1.2.3.8(C)  
Tests ..... 6.3.3.2, 6.3.4.1.1 to 6.3.4.1.3  
Types of ..... 6.3.2.2.6.1, A.6.3.2.2.6.1  
Wet procedure locations ..... 6.3.2.2.8.5  
**Reference grounding point** ..... 6.3.3.1.2(1)  
Definition ..... 3.3.155  
**Reference point** ..... 6.3.3.1.2, 6.3.3.1.4.1, 6.3.3.1.4.2  
**References** ..... Chap. 2, Annex D  
**Refrigerating equipment (definition)** ..... 3.3.156, A.3.3.156  
**Regulators**  
Cylinders ..... 11.2.5 to 11.2.7  
Medical air ..... 5.1.3.6.3.10(E), 5.1.3.6.3.10(F), 5.1.3.6.3.10(I),  
5.2.3.5(1), A.5.1.3.6.3.10(F)  
Pressure-reducing ..... *see* Pressure-reducing regulators  
**Remote (definition)** ..... 3.3.157, A.3.3.157  
**Reserve supply**  
Category 1  
Bulk cryogenic liquid systems ..... 5.1.3.5.12.3, 5.1.3.5.12.4,  
A.5.1.3.5.12.4  
In-building emergency reserves ..... 5.1.3.5.14  
Warning signals ..... 5.1.9.2.4, B.5.2.10 to B.5.2.13  
Category 3 ..... 5.1.9.2.4, B.5.2.10 to B.5.2.13  
Definition ..... 3.3.158  
**Reservoir jars** ..... 11.4.2.4  
**Resistance tests** ..... 10.3.2, 10.3.3.2, A.10.3.2  
**Respiratory therapy**  
Administration and maintenance ..... 11.5, A.11.5.1.1.3 to  
A.11.5.3.2  
Apparatus for ..... 11.4.2  
Carts and hand trucks ..... 11.4.3.1  
Equipment labeling ..... 11.5.3.1  
Equipment servicing and maintenance ..... 11.5.1.3  
Equipment transport, storage, and use ..... 11.5.3.3  
Fire hazards ..... 11.5.1.1, 11.5.1.2, A.11.5.1.1.2, A.11.5.1.1.3  
**Risers, piping**  
Definition ..... 3.3.144.3  
Valves ..... 5.1.4.6, 5.1.11.2.5  
**Risk assessment** ..... 4.2  
**Rubbish chutes** ..... 15.6

**-S-**

**Safety can (definition)** ..... 3.3.159  
**Safety mechanisms** ..... 11.6.4  
**Scavenging** ..... *see also* Waste anesthetic gas disposal;  
Waste anesthetic gas disposal systems  
Category 3 systems ..... 5.3.1.4, 5.3.8, 5.3.11.3, 5.3.12,  
A.5.3.8.3.9 to A.5.3.8.3.11(8), A.5.3.12  
Exhaust ..... 5.3.8.3.11  
Gas-powered device supply systems ..... 5.3.7.1.2  
General requirements ..... 5.3.8.1  
Maintenance ..... 5.3.13.4.4(5)  
Performance criteria and tests ..... 5.3.9

Piping ..... 5.3.8.2, 5.3.8.3, A.5.3.8.3.9 to A.5.3.8.3.11 (8)  
Source equipment ..... 5.3.8.3.9, 5.3.9.3.7, A.5.3.8.3.9  
Tests ..... 5.3.9, 5.3.12.1  
Definition ..... 3.3.160  
Ventilation system ..... 9.3.8  
Active system ..... 9.3.8.1.1  
Passive systems ..... 9.3.8.1.2  
**SCFM (standard cubic feet per minute) (definition)** ..... 3.3.161  
**Scope of standard** ..... 1.1, A.1.1.10, A.1.1.12  
**Security management** ..... Chap. 13  
Emergency ..... 12.5.3.3.6.3, A.12.5.3.3.6.3  
Post orders ..... 13.10.1, A.13.10.1  
Security-sensitive areas ..... 13.4, A.13.4.2(1) to A.13.4.7(1)  
Security vulnerability assessment ..... 13.2  
**Seismic restraint, Category 3 piped gas and vacuum systems** ..... 5.3.3  
**Selected receptacles (definition)** ..... 3.3.162  
**Self-extinguishing (definition)** ..... 3.3.163  
**Semipermanent connection (definition)** ..... 3.3.164  
**Sensors, inside hyperbaric chambers** ..... 14.2.8.1.1  
**Service inlets** ..... 5.3.9.2.5.8, 5.3.9.2.6.5, 5.3.9.2.6.7, A.5.3, A.5.3.8.3.9  
Definition ..... 3.3.165  
**Service outlets** ..... 5.3.9.2.5.8, 5.3.9.2.6.5, 5.3.9.2.6.7, A.5.3.6.17, A.5.3.7  
Definition ..... 3.3.166  
**Service valves** ..... 5.1.4.7, 5.1.11.2.6  
**Shall (definition)** ..... 3.2.7  
**Should (definition)** ..... 3.2.8  
**Shutoff valves**  
Accessibility ..... 5.1.4.2  
Air compressors ..... 5.3.7.6.1(10)  
Emergency oxygen supply connection (EOSC) ..... 5.1.3.5.13.2(3)  
Gas ..... 5.1.4.1 to 5.1.4.6, 5.3.6.19, 5.3.11.2, 5.3.13.2.5, A.5.1.4.5, A.5.3.6.19.1, B.5.2.17  
Gas equipment-laboratory ..... 11.4.3.2.2  
Hyperbaric facilities ..... 14.2.1.3.2  
Labeling and identification ..... 5.1.11.2, 5.3.11.2  
Scavenging systems ..... 5.3.8.3.8  
Types ..... 5.1.4.3  
Vacuum ..... 5.1.4.1 to 5.1.4.6, 5.3.8.3.8, A.5.1.4.5, B.5.2.17  
**Signs** ..... *see* Labeling and identification  
**Single treatment facilities (definition)** ..... 3.3.167, A.3.3.167  
**Site of intentional expulsion (definition)** ..... 3.3.168, A.3.3.168  
**Smoke alarms/detectors** ..... 15.7.3, 15.7.4.2.1, 15.7.4.2.2, 15.11.2, A.15.7.4.2.1, A.15.7.4.2.2  
**Smoking** ..... 11.5.1.1.1, 11.5.2.4, 11.5.3.2, 14.3.1.5.1.1(1), A.11.5.3.2  
**Sound-deadening materials** ..... 14.2.2.5.2  
**Source valves** ..... 5.1.4.4, 5.1.11.2.3  
**Sprinklers, automatic** ..... 7.3.1.2.3.9(B), 15.8, 15.10, 15.11.3, A.15.8.1.2, A.15.8.1.3, A.15.10, A.15.11.3  
**Staff** ..... *see* Employees  
**Staff emergency assistance call (nurse call system)** ..... 7.3.3.1.7, 7.3.3.1.9, 7.4.3.1.6  
**Standard**  
Adoption  
Requirements ..... 1.6  
Sample ordinance ..... Annex C  
Definition ..... 3.2.9  
Enforcement ..... 1.6.2  
**Standby power systems** ..... 15.5.1.3  
**Standpipe and hose systems** ..... 15.9.2, A.15.9.2.2  
**Station inlets**  
Category 1 ..... 5.1.2.3.3.1(D), 5.1.4.8, 5.1.5, 5.1.6.6 to 5.1.6.8, 5.1.7.5 to 5.1.7.7, 5.1.10.11.1.4, 5.1.11.3, 5.1.12.1.2, 5.1.12.1.10, 5.1.12.2.1.3(3), 5.1.12.2.4.6, 5.1.12.2.6.1, 5.1.12.3.3.1(D), 5.1.12.3.3.2(E), 5.1.12.3.3.2(G), 5.1.12.3.6.1, 5.1.12.3.6.3, 5.1.12.3.7.2 to 5.1.12.3.7.4, 5.1.12.3.8.2, 5.1.12.3.8.6, 5.1.12.3.10, 5.1.12.3.13, 5.1.14.2.3.1(10), 5.1.14.2.3.1(11), 5.1.14.4.9, A.5.1.5, A.5.1.12.2.5, A.5.1.14.2.3.1(11)  
Definition ..... 3.3.169

Category 2 ..... 5.2.5  
Category 3 ..... 5.3.9.2.5.8, 5.3.9.2.6.5, 5.3.9.2.6.7  
**Station outlets**  
Category 1 ..... 5.1.4.8, 5.1.5, 5.1.6.6 to 5.1.6.8, 5.1.7.5 to 5.1.7.7, 5.1.10.1.1, 5.1.10.10, 5.1.10.11.1.4, 5.1.11.3, 5.1.12.1.2, 5.1.12.1.10, 5.1.12.2.1.3(3), 5.1.12.2.2, A.5.1.5, B.5.2.18  
Category 2 ..... 5.2.5  
Category 3 ..... 5.3.6.23.3.10, 5.3.9.2.5.8, 5.3.9.2.6.5, 5.3.9.2.6.7  
Definition ..... 3.3.170  
**Storage**  
Compact ..... *see* Compact storage  
Containers ..... *see* Containers  
Cryogenic liquids, ventilation for storage of ..... 9.3.7, A.9.3.7.3, A.9.3.7.5.1  
Cylinders ..... *see* Cylinders  
Flammable and combustible liquids ..... 15.3, A.15.3.2  
Flammable gases ..... 14.3.3.3, 15.3, A.15.3.2  
Hyperbaric facilities ..... 14.2.1.5  
Nonflammable gases ..... 11.3.1, 11.3.2, A.11.3.1, A.11.3.2  
Oxygen ..... 5.1.3.1.9, 14.3.2.2, A.14.3.2.2  
Respiratory therapy equipment ..... 11.5.3.3  
Ventilation for medical gas storage ..... 9.3.7, A.9.3.7.3, A.9.3.7.5.1  
**Stored electrical energy systems** ..... 15.5.1.4  
**Supply source** ..... *see also* Category 1 piped gas and vacuum systems, sources; Category 3 piped gas and vacuum systems, sources  
Category 2 piped gas and vacuum systems ..... 5.2.3  
Operating supply (definition) ..... 3.3.171.1  
Primary supply (definition) ..... 3.3.171.2  
Reserve supply ..... *see* Reserve supply  
Secondary supply (definition) ..... 3.3.171.4  
**Supply systems;** ..... *see also* Category 1 piped gas and vacuum systems; Category 2 piped gas and vacuum systems; Category 3 piped gas and vacuum systems; Central supply systems; Pipe and piping, gas; Piped distribution systems  
Hyperbaric facilities ..... 14.2.4.1.3.2  
Portable ..... 11.4.1, A.11.4.1.1 to A.11.4.1.4  
**Support gases** ..... *see also* Instrument air; Nitrogen  
Category 1 piped gas and vacuum systems ..... *see* Category 1 piped gas and vacuum systems  
Medical ..... 5.1.1.2, A.5.1.1.2  
Definition ..... 3.3.109  
**Support rooms (definition)** ..... 3.3.138.4, A.3.3.138.4  
**Surface-mounted medical gas rail systems** ..... 5.1.7, 5.2.7, A.5.1.7  
Definition ..... 3.3.172, A.3.3.172  
**Switches** ..... *see also specific types of switches, such as* Transfer switches  
Essential electrical systems ..... 6.4.2.1, 6.4.2.2.6.3, 6.5.3.2, A.6.4.2.1.2 to A.6.4.2.1.8.3  
Hyperbaric facilities ..... 14.2.7.3.11, A.14.2.7.3.11.1  
Isolation switch, bypass ..... 6.4.2.1.8, A.6.4.2.1.8.3  
Test ..... 6.4.2.1.5.11  
**Synthetic materials** ..... *see* Textiles

**-T-**

**Task illumination (definition)** ..... 3.3.173  
**Telecommunications entrance facility (EF)** ..... 7.3.1.2.1, 7.4.1.1.1, 7.5.1.1.1 to 7.5.1.1.3, A.7.3.1.2.1.3(B) to A.7.3.1.2.1.6(C)  
Definition ..... 3.4.1  
**Telecommunications equipment room (TER)** ..... 7.3.1.2.1.1, 7.3.1.2.1.6, 7.3.1.2.2, 7.4.1.1.1, 7.5.1.1.3, A.7.3.1.2.1.6(C), A.7.3.1.2.2.2  
Definition ..... 3.4.2  
**Telecommunications room (TR)** ..... 7.3.1.2.3, 7.4.1.1.1, 7.5.1.1.3  
Definition ..... 3.4.3  
**Temperature**  
Generator sets and ..... 6.4.1.1.11  
Hyperbaric chambers ..... 14.2.4.3, 14.2.7.3.12, 14.3.2.1.8, A.14.2.4.3.2, A.14.2.7.3.12  
**Terminals**  
Definition ..... 3.3.174

Inlets ..... *see* Station inlets

**Test equipment** ..... 6.3.3.1.5

**Tests** ..... *see also* Performance tests

Elevators ..... 15.5.3.4

Fire protection systems ..... 14.2.5.5, 14.3.1.4.7, 15.12, A.14.2.5.5

Maintenance program

  Electrical systems ..... 6.3.4, A.6.3.4

  Gas and vacuum systems ..... 5.1.14.2.3, 5.1.14.4.1, 5.1.14.4.5 to 5.1.14.4.7, 5.3.14.4, A.5.1.14.2.3.1(1) to A.5.1.14.2.3.1(11), B.5.2

Prohibited interconnections for ..... 5.3.12.1

Records ..... 5.1.14.4.1, 5.3.9.1.1 to 5.3.9.1.5, 5.3.13.4.1, 5.3.13.4.5, 6.3.4.2, 6.4.4.2, 6.5.4.2, 6.6.4.2, 10.5.6.2, 10.5.6.3, A.6.3.4.2.1, A.10.5.6.2

Retests ..... B.5.2

**Test switches** ..... 6.4.2.1.5.11

**Textiles, hyperbaric chamber use** ..... 14.3.1.5.4, A.14.3.1.5.4

**Total hazard current (definition)** ..... 3.3.69.3

**Touch current**

  Definition ..... 3.3.175

  Limits ..... 10.3.5.1, A.10.3.5.1

  Portable equipment ..... 10.3.5, A.10.3.5.1

  Test procedure ..... 10.3.5.4

**Tracheotomy tube (definition)** ..... 3.3.177.2, A.3.3.177.2

**Training, employee**

  Electrical equipment ..... 10.5.8, A.10.5.8.1

  Emergency management ..... 12.5.3.3.6.7(B), 12.5.3.3.7

  Gas equipment and systems ..... 11.5.2.1, 11.6.1.2, A.11.5.2.1.1

  Hyperbaric facilities ..... 14.3.1.4.3 to 14.3.1.4.5, 14.3.6.4.1, A.14.3.1.4.5

  Operating rooms ..... 15.13.3.10

  Security personnel ..... 13.10.2, A.13.10

**Transfer switches** ..... 6.3.2.2.1.2, 6.4.2.1, 6.4.2.2.1.2, 6.4.2.2.1.4, A.6.4.2.1.2 to A.6.4.2.1.8.3; *see also* Switches

  Automatic ..... 6.4.2.1.4, 6.4.2.1.5, 6.4.3.2.5, A.6.4.2.1.5.1(A) to A.6.4.2.1.5.15

  Nonautomatic ..... 6.4.2.1.5.15, 6.4.2.1.6, 6.4.2.1.7, 6.4.3.2.8, 6.5.3.2.7, A.6.4.2.1.5.15

  Performance criteria and tests ..... 6.4.3.2, 6.4.4.1.1, 6.5.3.2, 6.5.4.1.1, 6.6.3.2, 6.6.3.3, 6.6.4.1.1, A.6.4.4.1.1.4(A)

**Transfilling** ..... 9.3.7, 11.5.2.2, 11.5.2.3, A.9.3.7.3, A.9.3.7.5.1

  Definition ..... 3.3.176

**Transformers, isolation** ..... 6.3.2.6.1

  Definition ..... 3.3.90

**Tube (medical)**

  Endotracheal (definition) ..... 3.3.177.1, A.3.3.177.1

  Tracheotomy tube (definition) ..... 3.3.177.2, A.3.3.177.2

**Tube (pipe)** ..... *see* Pipe and piping, gas

**-U-**

**Unattended laboratory operation (definition)** ..... 3.3.178, A.3.3.178

**Units of measurement** ..... 1.5, A.1.5

**Use point (definition)** ..... 3.3.179

**Utilities, fire protection for** ..... 15.5, A.15.5.2.1, A.15.5.3.3

**Utility center (J box) (definition)** ..... 3.3.180, A.3.3.180

**-V-**

**Vacuum indicators** ..... 5.1.8, 5.2.8

**Vacuum pumps**

  Alarms ..... 5.1.9.5, A.5.1.9.5

  Category 1 systems ..... 5.1.3.7.2, 5.1.3.7.6.1 to 5.1.3.7.6.5

  Category 3 systems ..... 5.3.6.20.5, 5.3.8.3.9.1(1)

  Electrical load reduction ..... 6.4.1.1.3

**Vacuum receivers** ..... 5.1.3.7.3

**Vacuum systems** ..... *see* Medical-surgical vacuum systems

**Vacuum terminals** ..... *see* Station inlets

**Valves** ..... *see also* Pressure relief valves; Shutoff valves

  Category 1 ..... 5.1.3.6.3.10(G), 5.1.3.6.3.15(C) (8), 5.1.4, 5.1.12.3.4, 5.1.13.3, 5.1.14.2.3.1(8), A.5.1.4, A.5.2.3.1(8), B.5.2.17

  Category 2 ..... 5.2.4

  Category 3 ..... 5.1.3.5.13.2, 5.3.6.2.2, 5.3.6.18.2, 5.3.6.19, 5.3.6.21.2, 5.3.6.21.4, 5.3.7.4, 5.3.7.6.1(10), 5.3.7.6.1(11), 5.3.7.7.2, 5.3.7.8.2, 5.3.7.8.4, 5.3.8.3.8, 5.3.13.4.4(1), A.5.3.6.19.1

  Gas equipment, cylinder and container sources for ..... 11.2.2

  In-line ..... 5.1.4.9, 5.1.4.11

  Service ..... 5.1.4.7, 5.1.11.2.6

  Source ..... 5.1.4.4, 5.1.11.2.3

  Zone ..... 5.1.4.8

**Vaporizers (definition)** ..... 3.3.181

**Ventilation** ..... *see also* Exhaust systems; Heating, ventilating, and air conditioning (HVAC) systems

  Air compressors ..... 5.3.7.5.2

  Alternate power sources ..... 6.4.1.1.12, 6.4.2.2.5.3(A) (5), 6.4.2.2.5.3(A) (6), 6.4.2.2.5.3(B), A.6.4.1.1.12

  Central supply systems and storage, gas ..... 5.1.3.3.3

  Construction, during ..... 9.3.11

  Cryogenic liquids, storage or transfilling of ..... 9.3.7, A.9.3.7.3, A.9.3.7.5.1

  Definition ..... 9.1.4.1

  Hyperbaric chambers ..... 14.2.4, 14.2.9.2, A.14.2.4.1.2, A.14.2.9.2

  Laboratories ..... 15.5.2.4

  Manifolds ..... 5.1.13.2.3.1(5)

  Medical gas, storage or transfilling of ..... 9.3.7, A.9.3.7.3, A.9.3.7.5.1

  Waste gas ..... 9.3.8

**Venting** ..... *see* Ventilation

**Voltage limit** ..... 6.3.3.1.6.1

**Voltages**

  Abnormal ..... 6.4.1.1.1.2(1), 6.4.1.1.2

  Measuring ..... 6.3.3.1.2 to 6.3.3.1.5, A.6.3.3.1.3, A.6.3.3.1.4

**Voltage sensing** ..... 6.4.2.1.5.1(D)

**-W-**

**Warning signs** ..... *see* Labeling and identification

**Warning systems** ..... *see* Alarm systems

**Waste anesthetic gas disposal (WAGD) systems** ..... 5.1.1.3

  Alarms ..... 5.1.3.8.4

  Area ..... 5.1.9.3, A.5.1.9.3.1 to A.5.1.9.3.4(2)

  Local ..... 5.1.9.5, A.5.1.9.5

  Master ..... 5.1.9.2.4(11)

  Category 1 piped gas and vacuum systems ..... 5.1.3.3.1.3(3), 5.1.3.5(6), 5.1.3.8, 5.1.10.2.3, 5.1.10.3, 5.1.14.1.3, 5.1.14.1.4, 5.1.14.4.7(3), A.5.1.3.8, A.5.1.10.3.1, A.5.1.14.1.3, A.5.1.14.1.4

  Category 2 piped gas and vacuum systems ..... 5.2.3.7

  Definition ..... 3.3.183

  Designation colors ..... Table 5.1.11

  Electrical power and control ..... 5.1.3.8.5

  Exhaust ..... 5.1.3.8.6, 5.1.13.2.3.1(3)

  Interface (definition) ..... 3.3.182, A.3.3.182

  Maintenance ..... 5.1.14.2, 5.1.14.4.7(3), A.5.1.14.2.1 to A.5.1.14.2.3.1(11)

  Operating pressures ..... Table 5.1.11

  Producers ..... 5.1.3.8.1, 5.1.3.8.2, A.5.1.3.8.1

  Sources ..... 5.1.3.8.1, A.5.1.3.8.1

  Special precautions ..... 5.1.14.1.3, 5.1.14.1.4, A.5.1.14.1.3, A.5.1.14.1.4

  Ventilation system ..... 9.3.8

**Waste water** ..... 8.3.9 to 8.3.11

**Water, potable and nonpotable** ..... 8.3.1, 8.3.2, 12.5.3.3.6.5, A.12.5.3.3.6.5

**Water conditioning** ..... 8.3.4

**Water heating** ..... 8.3.3

**Welded joints** ..... 5.1.10.3.1(2), 5.1.10.5, A.5.1.10.5.1.5

<b>Wet procedure locations</b> .....	1.3.4.3, 6.3.2.2.8, A.6.3.2.2.8.1 to A.6.3.2.2.8.7	<b>-X-</b>	
Definition .....	3.3.184, A.3.3.184	<b>X-ray equipment</b> .....	14.3.2.1.2(1)
<b>Wiring</b> .....	<i>see</i> Electrical wiring	<b>-Z-</b>	
<b>Working pressure (definition)</b> .....	3.3.147.7, A.3.3.147.7	<b>Zone valves</b> .....	5.1.4.8
<b>Work space or room</b>			
Generators .....	6.4.1.1.8		
Telecommunications facility .....	7.3.1.2.2.4, 7.3.1.2.3.5		



Tentative Interim Amendment

**NFPA<sup>®</sup> 99**  
**Health Care Facilities Code**  
**2012 Edition**

**Reference:** 5.1.1.6, 5.2.1.2, and 5.3.1.1.2

**TIA 12-4**

*(SC 13-3-8/TIA Log #1084)*

Pursuant to Section 5 of the NFPA *Regulations Governing the Development of NFPA Standards*, the National Fire Protection Association has issued the following Tentative Interim Amendment to NFPA 99, *Health Care Facilities Code*, 2012 edition. The TIA was processed by the Technical Committee on Piping Systems and the Correlating Committee on Health Care Facilities, and was issued by the Standards Council on March 7, 2013, with an effective date of March 27, 2013.

A Tentative Interim Amendment is tentative because it has not been processed through the entire standards-making procedures. It is interim because it is effective only between editions of the standard. A TIA automatically becomes a public input of the proponent for the next edition of the standard; as such, it then is subject to all of the procedures of the standards-making process.

*1. Revise 5.1.1.6 to read as follows:*

**5.1.1.6** The following subsections of this chapter shall apply to the operation, management, and maintenance of Category 1 medical gas and vacuum systems in existing facilities:

- (1) 5.1.2
- (2) 5.1.3.1
- (3) 5.1.3.2
- (4) 5.1.3.3.1.7
- (5) 5.1.3.3.1.8
- (6) 5.1.3.3.4
- (7) 5.1.3.6.2
- (8) 5.1.3.8.5.2
- (9) 5.1.14
- (10) 5.1.15

*2. Revise 5.2.1.2 to read as follows:*

**5.2.1.2** The following subsections of this chapter shall apply to the operation, management, and maintenance of Category 2 medical gas and vacuum systems in existing health care facilities:

- (1) 5.1.3.3.1.7
- (2) 5.1.3.3.1.8
- (3) 5.1.3.3.4
- (4) 5.1.3.6.2
- (5) 5.1.3.8.5.2
- (6) 5.1.10.11.7.1
- (7) 5.2.3.1

- (8) 5.2.3.2
- (9) 5.2.3.5(2)
- (10) 5.2.3.6(2)
- (11) 5.2.3.7(2)
- (12) 5.2.13
- (13) 5.2.14

3. *Revise 5.3.1.1.2 to read as follows:*

**5.3.1.1.2** The following subsections of this chapter shall apply to the operation, management, and maintenance of Category 3 medical gas and vacuum systems in existing health care facilities:

- (1) 5.3.1.5
- (2) 5.3.1.6
- (3) 5.3.2
- (4) 5.3.6.19.4
- (5) 5.3.6.20.3
- (6) 5.3.6.20.4
- (7) 5.3.6.20.5
- (8) 5.3.6.20.6
- (9) 5.3.6.20.7
- (10) 5.3.6.20.8
- (11) 5.3.6.20.9
- (12) 5.3.6.21.14
- (13) 5.3.6.23.1.5
- (14) 5.3.10
- (15) 5.3.12
- (16) 5.3.13

**Issue Date:** March 7, 2013

**Effective Date:** March 27, 2013

(Note: For further information on NFPA Codes and Standards, please see <http://www.nfpa.org/docinfolist>)

Copyright © 2013 All Rights Reserved  
NATIONAL FIRE PROTECTION ASSOCIATION





Tentative Interim Amendment

# NFPA<sup>®</sup> 99

## Health Care Facilities Code

### 2012 Edition

**Reference:** 6.6.2.2.3.2, 6.6.3.1 through 6.6.3.1.2

**TIA 12-3**

*(SC 12-8-42/TIA Log #1064)*

Pursuant to Section 5 of the NFPA Regulations Governing Committee Projects, the National Fire Protection Association has issued the following Tentative Interim Amendment to NFPA 99, *Health Care Facilities Code*, 2012 edition. The TIA was processed by the Technical Committee on Electrical Systems and the Correlating Committee on Health Care Facilities, and was issued by the Standards Council on August 9, 2012, with an effective date of August 29, 2012.

A Tentative Interim Amendment is tentative because it has not been processed through the entire standards-making procedures. It is interim because it is effective only between editions of the standard. A TIA automatically becomes a proposal of the proponent for the next edition of the standard; as such, it then is subject to all of the procedures of the standards-making process.

*1. Revise 6.6.3.1 through 6.6.3.1.2 to read:*

#### **6.6.3.1 Source.**

**6.6.3.1.1** The life safety branch shall have an alternate source of power separate and independent from the normal source that will be effective for a minimum of 1 1/2 hours after loss of the normal source.

**6.6.3.1.2** The life safety branch shall be so arranged that, in the event of failure of the normal power source, the alternate source of power shall be automatically connected to the load within 10 seconds.

**Issue Date:** August 9, 2012

**Effective Date:** August 29, 2012

**(Note: For further information on NFPA Codes and Standards, please see [www.nfpa.org/codelist](http://www.nfpa.org/codelist))**

Copyright © 2012 All Rights Reserved  
NATIONAL FIRE PROTECTION ASSOCIATION



Tentative Interim Amendment

**NFPA<sup>®</sup> 99**  
**Health Care Facilities Code**  
**2012 Edition**

**Reference:** 10.2.3.6(5) and A.10.2.3.6(5)

**TIA 12-5**

*(SC 13-8-18/TIA Log #1104)*

Pursuant to Section 5 of the NFPA *Regulations Governing the Development of NFPA Standards*, the National Fire Protection Association has issued the following Tentative Interim Amendment to NFPA 99, *Health Care Facilities Code*, 2012 edition. The TIA was processed by the Technical Committee on Medical Equipment and the Correlating Committee on Health Care Facilities, and was issued by the Standards Council on August 1, 2013, with an effective date of August 20, 2013.

A Tentative Interim Amendment is tentative because it has not been processed through the entire standards-making procedures. It is interim because it is effective only between editions of the standard. A TIA automatically becomes a public input of the proponent for the next edition of the standard; as such, it then is subject to all of the procedures of the standards-making process.

- 1. Delete entire subsection 10.2.3.6(5).*
- 2. Delete corresponding Annex A material A.10.2.3.6(5).*

**Issue Date:** August 1, 2013

**Effective Date:** August 20, 2013

**(Note: For further information on NFPA Codes and Standards, please see <http://www.nfpa.org/docinfolist>)**

Copyright © 2013 All Rights Reserved  
NATIONAL FIRE PROTECTION ASSOCIATION



Tentative Interim Amendment

# NFPA<sup>®</sup> 99

## Health Care Facilities Code

### 2012 Edition

**Reference:** 11.5.1.1.2 through 11.5.1.1.4 and A.11.5.1.1.2 through A.11.5.1.1.3

#### **TIA 12-6**

*(SC 14-3-9/TIA Log #1125)*

Pursuant to Section 5 of the NFPA *Regulations Governing the Development of NFPA Standards*, the National Fire Protection Association has issued the following Tentative Interim Amendment to NFPA 99, *Health Care Facilities Code*, 2013 edition. The TIA was processed by the Technical Committee on Medical Equipment and the Health Care Facilities Correlating Committee, and was issued by the Standards Council on March 3, 2014, with an effective date of March 23, 2014.

A Tentative Interim Amendment is tentative because it has not been processed through the entire standards-making procedures. It is interim because it is effective only between editions of the standard. A TIA automatically becomes a public input of the proponent for the next edition of the standard; as such, it then is subject to all of the procedures of the standards-making process.

*1. Revise text to read as follows:*

#### **11.5.1.1 Elimination of Sources of Ignition.**

**11.5.1.1.1** Smoking materials (e.g., matches, cigarettes, lighters, lighter fluid, tobacco in any form) shall be removed from patients receiving respiratory therapy.

**11.5.1.1.2\*** When a nasal cannula and its associated supply tubing are delivering oxygen outside of a patient care room, no sources of open flame shall be permitted in the site of intentional expulsion.

**11.5.1.1.3\*** When any other oxygen delivery equipment not specified in 11.5.1.1.2 is in use, ~~No~~no sources of open flame shall be permitted in the area of administration.

**11.5.1.1.4\*** Solid fuel-burning appliances shall not be permitted in the area of administration.

**11.5.1.1.5\*** Sparking toys shall not be permitted in any patient care room.

**11.5.1.1.6** Nonmedical appliances that have hot surfaces or sparking mechanisms shall not be permitted within oxygen-delivery equipment or within the site of intentional expulsion.

**A.11.5.1.1.2** Outside of a patient care room, 11.5.1.1.2 prohibits sources of open flames within the site of intentional expulsion [1 ft (0.3 m)] of a nasal cannula. No sources of open flame are permitted within the area of administration [15 ft (4.3 m)] for other types of oxygen delivery equipment or in patient care rooms (see 11.5.1.1.3).

The amount of oxygen delivered by a nasal cannula is limited. One (1) ft (0.3 m) is sufficient separation from an oxygen-enriched atmosphere produced by a nasal cannula which is an oxygen delivery equipment used outside of patient care areas. In the open air, dilution goes to ambient levels (not oxygen-enriched atmosphere) within a few inches of the cannula openings, but 12 in. (300 mm) provides an adequate safety factor. Other oxygen delivery equipment such as masks, are not included since masks would not typically be associated with mobile patients in health care facilities and may deliver greater quantities of oxygen than nasal cannula.

The household-style nursing homes that include kitchens intended for residents' use and enclosed gas fireplaces present a source of flame ignition to which residents will be exposed. Residents utilizing a nasal cannula would potentially not be allowed to participate in the cooking because it would place the cooking flame within the site of intentional expulsion. However, they would be allowed in the kitchen area to assist in preparing the food and to socialize with other residents and staff in the kitchen similar to what happens in the kitchens of residential environments.

The primary concern is that flame-producing equipment exists in many places in a nursing home and that it would be impractical to maintain a resident with a nasal cannula a minimum of 15 ft (4.3 m) (Area of Administration) away from the flame-producing equipment. Typical flame-producing equipment found in a nursing home includes the following:

1. Candles in chapels
2. Open kitchens using gas cooking equipment
3. Fireplaces
4. Fuel-fired heating equipment
5. Private family dining rooms using fuel-fired equipment
6. Canned cooking fuel (e.g., used under chafing dishes)

**A.11.5.1.1.3** Patients and hospital personnel in the area of administration should be advised of respiratory therapy hazards and regulations.

Visitors should be cautioned of these hazards through the prominent posting of signs. (*See 11.3.4.*)

**A.11.5.1.1.4** Solid fuel-burning appliances include wood-burning fireplaces, wood stoves, and similar appliances. These pose a greater risk in locations where oxygen is being provided than gas-fueled appliances, in part due to their ability to emit embers into the environment.

**A.11.5.1.1.5** Such toys have been associated with fire incidents in health care facilities.

A suggested text for precautionary signs for oxygen tent canopies and oxygen hoods used in pediatric nursing units is the following:

CAUTION: OXYGEN IN USE  
ONLY TOYS APPROVED BY  
NURSES MAY BE GIVEN TO CHILD

**Issue Date:** March 3, 2014

**Effective Date:** March 23, 2014

(Note: For further information on NFPA Codes and Standards, please see [www.nfpa.org/codelist](http://www.nfpa.org/codelist))

Copyright © 2014 All Rights Reserved  
NATIONAL FIRE PROTECTION ASSOCIATION

## *Sequence of Events Leading to Issuance of an NFPA Committee Document*

### **Step 1: Call for Proposals**

- Proposed new Document or new edition of an existing Document is entered into one of two yearly revision cycles, and a Call for Proposals is published.

### **Step 2: Report on Proposals (ROP)**

- Committee meets to act on Proposals, to develop its own Proposals, and to prepare its Report.
- Committee votes by written ballot on Proposals. If two-thirds approve, Report goes forward. Lacking two-thirds approval, Report returns to Committee.
- Report on Proposals (ROP) is published for public review and comment.

### **Step 3: Report on Comments (ROC)**

- Committee meets to act on Public Comments to develop its own Comments, and to prepare its report.
- Committee votes by written ballot on Comments. If two-thirds approve, Report goes forward. Lacking two-thirds approval, Report returns to Committee.
- Report on Comments (ROC) is published for public review.

### **Step 4: Technical Report Session**

- “*Notices of intent to make a motion*” are filed, are reviewed, and valid motions are certified for presentation at the Technical Report Session. (“Consent Documents” that have no certified motions bypass the Technical Report Session and proceed to the Standards Council for issuance.)
- NFPA membership meets each June at the Annual Meeting Technical Report Session and acts on Technical Committee Reports (ROP and ROC) for Documents with “certified amending motions.”
- Committee(s) vote on any amendments to Report approved at NFPA Annual Membership Meeting.

### **Step 5: Standards Council Issuance**

- Notification of intent to file an appeal to the Standards Council on Association action must be filed within 20 days of the NFPA Annual Membership Meeting.
- Standards Council decides, based on all evidence, whether or not to issue Document or to take other action, including hearing any appeals.

## *Committee Membership Classifications*

The following classifications apply to Technical Committee members and represent their principal interest in the activity of the committee.

- M *Manufacturer*: A representative of a maker or marketer of a product, assembly, or system, or portion thereof, that is affected by the standard.
- U *User*: A representative of an entity that is subject to the provisions of the standard or that voluntarily uses the standard.
- I/M *Installer/Maintainer*: A representative of an entity that is in the business of installing or maintaining a product, assembly, or system affected by the standard.
- L *Labor*: A labor representative or employee concerned with safety in the workplace.
- R/T *Applied Research/Testing Laboratory*: A representative of an independent testing laboratory or independent applied research organization that promulgates and/or enforces standards.
- E *Enforcing Authority*: A representative of an agency or an organization that promulgates and/or enforces standards.
- I *Insurance*: A representative of an insurance company, broker, agent, bureau, or inspection agency.
- C *Consumer*: A person who is, or represents, the ultimate purchaser of a product, system, or service affected by the standard, but who is not included in the *User* classification.
- SE *Special Expert*: A person not representing any of the previous classifications, but who has a special expertise in the scope of the standard or portion thereof.

#### NOTES:

1. “Standard” connotes code, standard, recommended practice, or guide.
2. A representative includes an employee.
3. While these classifications will be used by the Standards Council to achieve a balance for Technical Committees, the Standards Council may determine that new classifications of members or unique interests need representation in order to foster the best possible committee deliberations on any project. In this connection, the Standards Council may make appointments as it deems appropriate in the public interest, such as the classification of “Utilities” in the National Electrical Code Committee.
4. Representatives of subsidiaries of any group are generally considered to have the same classification as the parent organization.

# NFPA Document Proposal Form

**NOTE: All Proposals must be received by 5:00 pm EST/EDST on the published Proposal Closing Date.**

**For further information on the standards-making process, please contact the Codes and Standards Administration at 617-984-7249 or visit [www.nfpa.org/codes](http://www.nfpa.org/codes).**

**For technical assistance, please call NFPA at 1-800-344-3555.**

## FOR OFFICE USE ONLY

Log #: \_\_\_\_\_

Date Rec'd: \_\_\_\_\_

Please indicate in which format you wish to receive your ROP/ROC  electronic  paper  download  
(Note: If choosing the download option, you must view the ROP/ROC from our website; no copy will be sent to you.)

Date April 1, 200X Name John J. Doe Tel. No. 716-555-1234

Company Air Canada Pilot's Association Email \_\_\_\_\_

Street Address 123 Summer Street Lane City Lewiston State NY Zip 14092

**\*\*\*If you wish to receive a hard copy, a street address MUST be provided. Deliveries cannot be made to PO boxes.**

Please indicate organization represented (if any) \_\_\_\_\_

1. (a) NFPA Document Title National Fuel Gas Code NFPA No. & Year 54, 200X Edition

(b) Section/Paragraph 3.3

2. Proposal Recommends (check one):  new text  revised text  deleted text

3. Proposal (include proposed new or revised wording, or identification of wording to be deleted): [Note: Proposed text should be in legislative format; i.e., use underscore to denote wording to be inserted (inserted wording) and strike-through to denote wording to be deleted (~~deleted wording~~).]

Revise definition of effective ground-fault current path to read:

3.3.78 Effective Ground-Fault Current Path. An intentionally constructed, permanent, low impedance electrically conductive path designed and intended to carry ~~underground electric fault current conditions~~ from the point of a ground fault on a wiring system to the electrical supply source.

4. Statement of Problem and Substantiation for Proposal: (Note: State the problem that would be resolved by your recommendation; give the specific reason for your Proposal, including copies of tests, research papers, fire experience, etc. If more than 200 words, it may be abstracted for publication.)

Change uses proper electrical terms.

## 5. Copyright Assignment

(a)  I am the author of the text or other material (such as illustrations, graphs) proposed in the Proposal.

(b)  Some or all of the text or other material proposed in this Proposal was not authored by me. Its source is as follows: (please identify which material and provide complete information on its source)

ABC Co.

I hereby grant and assign to the NFPA all and full rights in copyright in this Proposal and understand that I acquire no rights in any publication of NFPA in which this Proposal in this or another similar or analogous form is used. Except to the extent that I do not have authority to make an assignment in materials that I have identified in (b) above, I hereby warrant that I am the author of this Proposal and that I have full power and authority to enter into this assignment.

Signature (Required)

John J. Doe

**PLEASE USE SEPARATE FORM FOR EACH PROPOSAL**

Mail to: Secretary, Standards Council · National Fire Protection Association  
1 Batterymarch Park · Quincy, MA 02169-7471 OR  
Fax to: (617) 770-3500 OR Email to: [proposals\\_comments@nfpa.org](mailto:proposals_comments@nfpa.org)

# NFPA Document Proposal Form

**NOTE: All Proposals must be received by 5:00 pm EST/EDST on the published Proposal Closing Date.**

**For further information on the standards-making process, please contact the Codes and Standards Administration at 617-984-7249 or visit [www.nfpa.org/codes](http://www.nfpa.org/codes).**  
**For technical assistance, please call NFPA at 1-800-344-3555.**

**FOR OFFICE USE ONLY**  
Log #: \_\_\_\_\_  
Date Rec'd: \_\_\_\_\_

Please indicate in which format you wish to receive your ROP/ROC  electronic  paper  download  
(Note: If choosing the download option, you must view the ROP/ROC from our website; no copy will be sent to you.)

Date \_\_\_\_\_ Name \_\_\_\_\_ Tel. No. \_\_\_\_\_  
Company \_\_\_\_\_ Email \_\_\_\_\_  
Street Address \_\_\_\_\_ City \_\_\_\_\_ State \_\_\_\_\_ Zip \_\_\_\_\_

**\*\*\*If you wish to receive a hard copy, a street address MUST be provided. Deliveries cannot be made to PO boxes.**

Please indicate organization represented (if any) \_\_\_\_\_

1. (a) NFPA Document Title \_\_\_\_\_ NFPA No. & Year \_\_\_\_\_

(b) Section/Paragraph \_\_\_\_\_

2. Proposal Recommends (check one):  new text  revised text  deleted text

3. Proposal (include proposed new or revised wording, or identification of wording to be deleted): [Note: Proposed text should be in legislative format; i.e., use underscore to denote wording to be inserted (inserted wording) and strike-through to denote wording to be deleted (~~deleted wording~~).]

4. Statement of Problem and Substantiation for Proposal: (Note: State the problem that would be resolved by your recommendation; give the specific reason for your Proposal, including copies of tests, research papers, fire experience, etc. If more than 200 words, it may be abstracted for publication.)

## 5. Copyright Assignment

(a)  I am the author of the text or other material (such as illustrations, graphs) proposed in the Proposal.

(b)  Some or all of the text or other material proposed in this Proposal was not authored by me. Its source is as follows: (please identify which material and provide complete information on its source)

\_\_\_\_\_

*I hereby grant and assign to the NFPA all and full rights in copyright in this Proposal and understand that I acquire no rights in any publication of NFPA in which this Proposal in this or another similar or analogous form is used. Except to the extent that I do not have authority to make an assignment in materials that I have identified in (b) above, I hereby warrant that I am the author of this Proposal and that I have full power and authority to enter into this assignment.*

Signature (Required) \_\_\_\_\_

**PLEASE USE SEPARATE FORM FOR EACH PROPOSAL**

Mail to: Secretary, Standards Council · National Fire Protection Association  
1 Batterymarch Park · Quincy, MA 02169-7471 OR  
Fax to: (617) 770-3500 OR Email to: [proposals\\_comments@nfpa.org](mailto:proposals_comments@nfpa.org)